

Features

- 15" New Generation Stainless Steel Panel PC
- NXP i.MX 8M Plus, Quad Core, 1.8GHz Onboard Processor
- True Flat Front Bezel Design and Grade 304 Stainless Steel Enclosure (Grade 316 for option)
- IP66/IP69K Rated with M12 Connectors
- Support Resistive Touch, Projected Capacitive Touch, and Glass
- Touch on/off Button on the Side Edge for Hygienic Cleaning
- Support Ergonomic Versatile Mounting: Yoke Mounting / Space-saving VESA 100 x 100 mm Mounting

Specifications

System	
CPU	NXP i.MX 8M Plus ARM, Cortex-A53(4x Cores, 1.6 GHz)
System Chipset	SoC
Memory	Onboard 4GB LPDDR4-4000 SDRAM

IO Port	
USB	1 x M12 8-pin for 2 x USB 2.0 with waterproof cover and chain
Serial / Parallel	1 x M12 8-pin COM1, RS-232/422/485, default RS-232, with waterproof cover and chain
LAN	1 x M12 8-pin for LAN with waterproof cover and chain
Others	1 x Touch on/off button at the side
Power Connector	1 x Power switch on the rear (option)
Option	2 x M12 blank for option: • 1 x LAN • 1 x COM • 1 x CAN

Storage Space	
eMMC	Onboard 16GB(default)/ optional up to 64GB eMMC Flash

Expansion	
Expansion slot	1 x M.2 B-Key 3042/3052 for 4G/5G module 1 x M.2 E-Key 2230 for WIFI/BT module 1 x Nano SIM slot
RFID module	RFID module design on the front side(optional)

Display	Standard	High Brightness Optional
Display Type	15" TFT-LCD	15" TFT-LCD
Max. Resolution	1024 x 768	1024 x 768
Max. Color	16.2M	16.7M
Luminance (cd/m ²)	300	1000
View Angle	176(H)/176(V)	176(H)/176(V)
Contrast	2000:1	3000:1
Backlight Lifetime	70,000 hrs	70,000 hrs

Touch Screen	
Type	Resistive Touch (For R model) Projected Capacitive Touch (For P model) Glass (For G model)
Interface	USB
Light Transmission(%)	Resistive Touch: 80% Projected Capacitive Touch: 90%

Power	
Power Input	DC 24V
Power Consumption	ViTAM-615AP: 18.62W

Dimensions

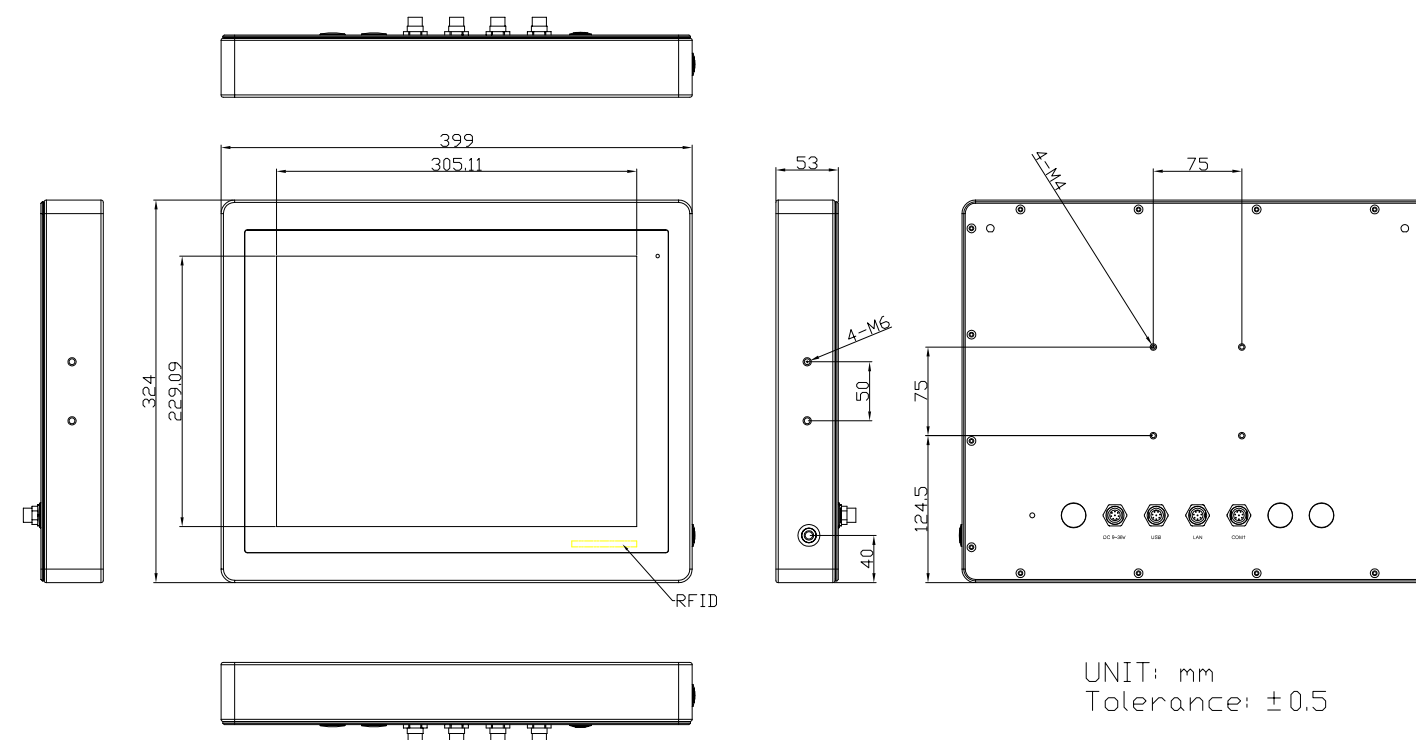

UNIT: mm
Tolerance: ±0.5

Mechanical	
Construction	304 Stainless Steel Chassis(default), 316 Stainless Steel Chassis(optional)
Mounting	VESA Mount 100 x 100, Yoke Mount (optional)
IP Rating	Total IP66/IP69K
Dimensions	399 x 324 x 53 mm
Net Weight	6.65 kg

Environmental	
Operating Temperature	0~50°C / -20~60°C for option
Storage Temperature	-30~70°C
Humidity	10 to 95% @ 40°C, non- condensing
Certificate	CE/FCC Class A

Operating System Support	
Android 11 / Yocto Linux 4.0 (Kirkstone)	

Ordering Information	
ViTAM-615AP	15" XGA IP66/IP69K stainless steel panel pc, NXP i.MX 8M Plus ARM, Cortex-A53, 4GB LPDDR4 RAM, 16GB eMMC, projected capacitive touch, 24V DC power input with Adapter
ViTAM-615AR	15" XGA IP66/IP69K stainless steel panel pc, NXP i.MX 8M Plus ARM, Cortex-A53, 4GB LPDDR4 RAM, 16GB eMMC, 5 wire resistive touch window, 24V DC power input with Adapter
ViTAM-615AG	15" XGA IP66/IP69K stainless steel panel pc, NXP i.MX 8M Plus ARM, Cortex-A53, 4GB LPDDR4 RAM, 16GB eMMC, protection glass, 24V DC power input with Adapter
ViTAM-615APH	15" XGA IP66/IP69K stainless steel panel pc, NXP i.MX 8M Plus ARM, Cortex-A53, 4GB LPDDR4 RAM, 16GB eMMC, projected capacitive touch, 24V DC power input with Adapter, 1,000 nits LCD
ViTAM-615ARH	15" XGA IP66/IP69K stainless steel panel pc, NXP i.MX 8M Plus ARM, Cortex-A53, 4GB LPDDR4 RAM, 16GB eMMC, 5 wire resistive touch window, 24V DC power input with Adapter, 1,000 nits LCD
ViTAM-615AGH	15" XGA IP66/IP69K stainless steel panel pc, NXP i.MX 8M Plus ARM, Cortex-A53, 4GB LPDDR4 RAM, 16GB eMMC, protection glass, 24V DC power input with Adapter, 1,000 nits LCD