

RS9116-QMS EVK Daughter Board Block Diagram

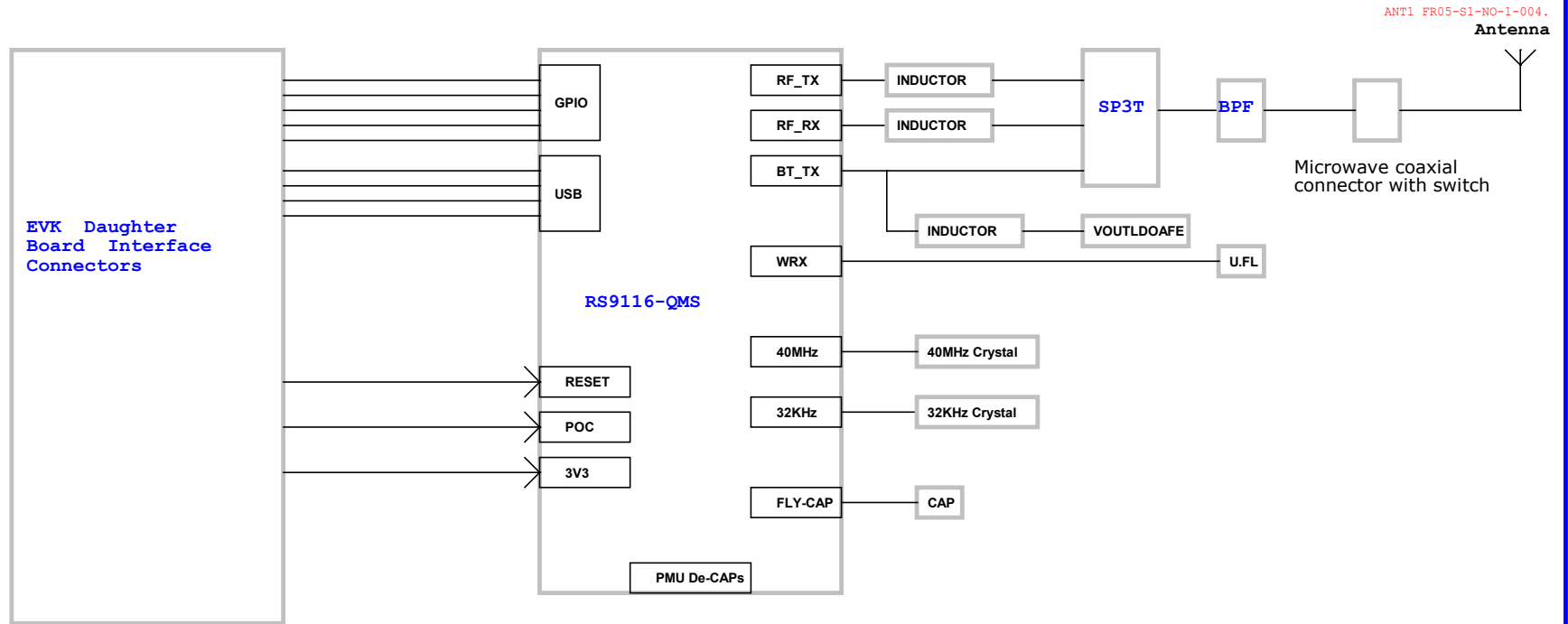

Silicon Labs Confidential

		400 W Cesar Chavez Austin, TX 78701	
		Size	Title
		RS9116X-SB-EVK1- Daughter Board	
Part Number	Document Number	Rev	
<Part Number>	Block Diagram	1.5	
Date:	Thursday, September 24, 2020	Sheet	1 of 4

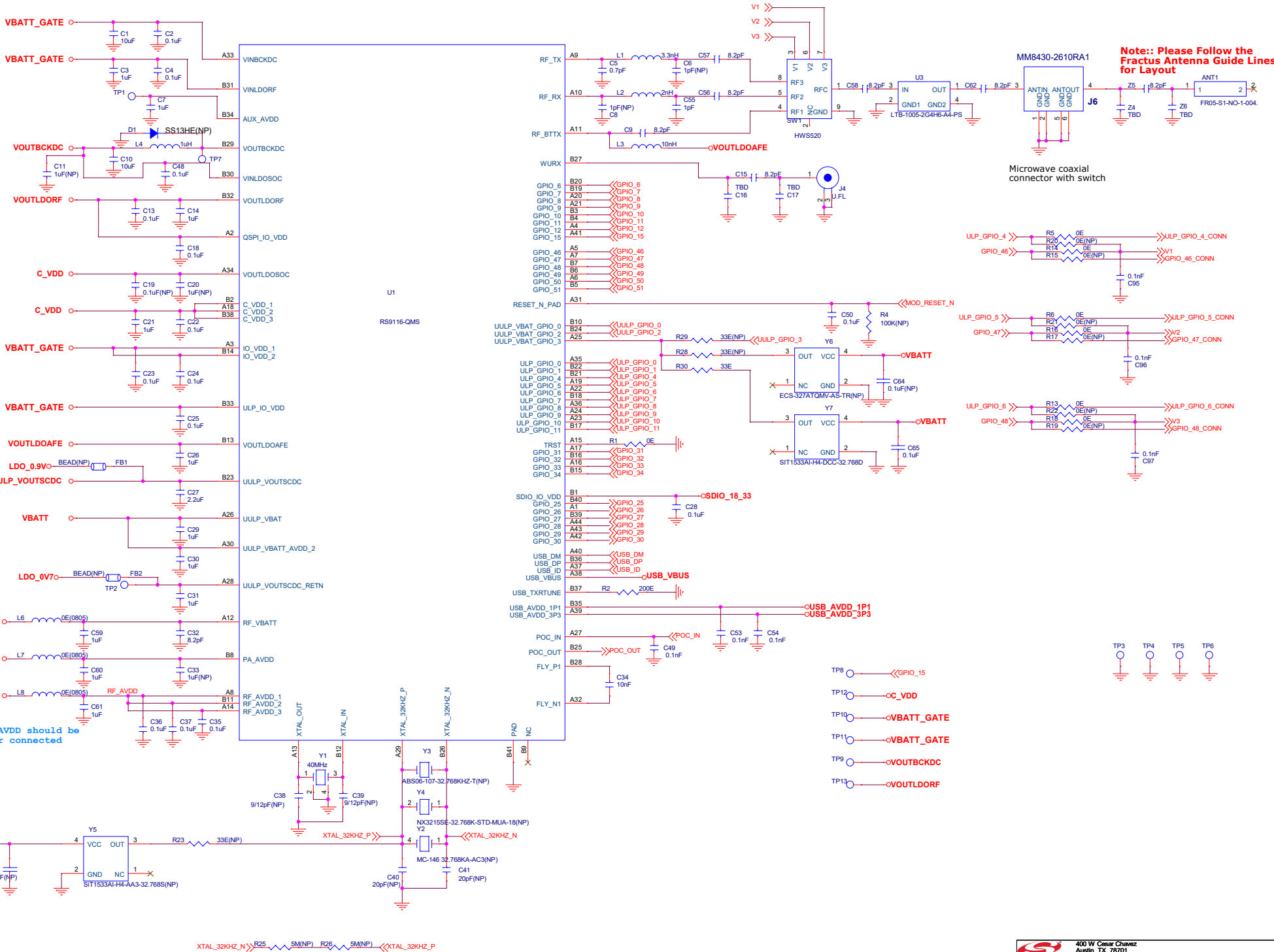

Silicon Labs Confidential

		400 W Cesar Chavez Austin, TX 78701	
Size	Title	RS9116X-SB-EVK1- Daughter Board	
Part Number	Document Number	RS9116-QMS	
Date:	Thursday, September 24, 2020	Sheet	2 of 4
Rev	1.5		

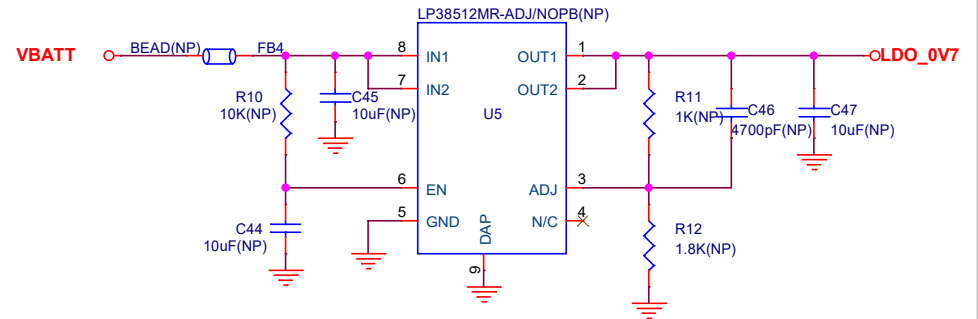
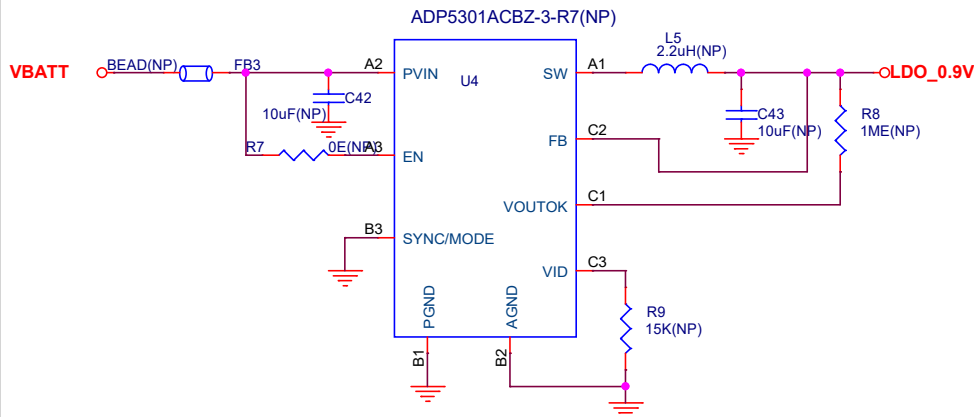
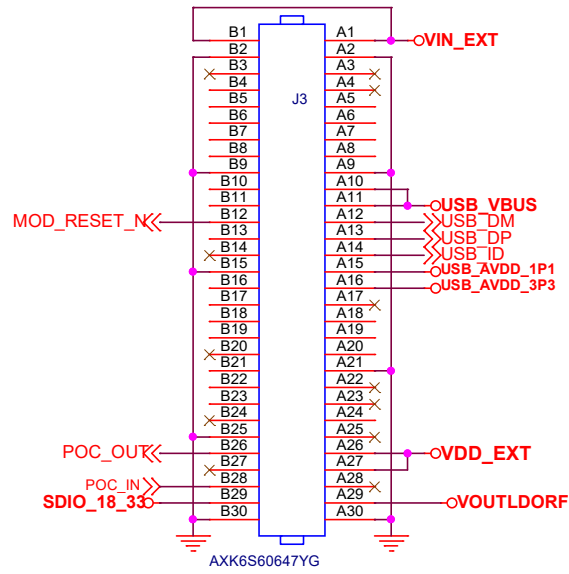
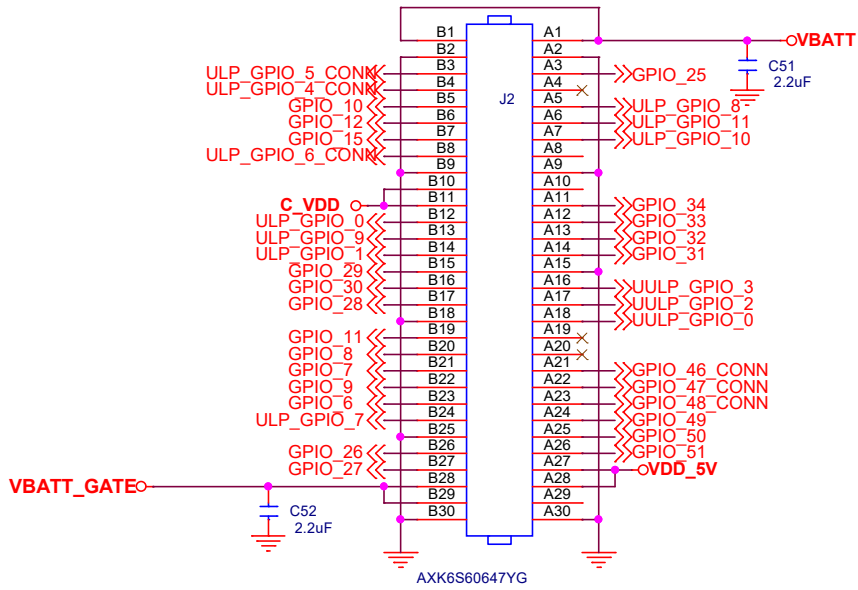

Silicon Labs Confidential

 400 W Cesar Chavez Austin, TX 78701		Size Title	
		RS9116X-SB-EVK1- Daughter Board	
Part Number	Document Number	Rev 1.5	
<Part Number>	Connector		
Date: Thursday, September 24, 2020	Sheet 3 of 4		

Revision Changes

Revision 1.5

- 1) Added 32KHz Oscillator on UULP_GPIO_3
- 2) Added R25 & R26 between XTAL_32KHZ P & N pins
- 3) Title block changed from Redpine to Siliabs on 24th September 2020

Revision 1.2

- 1) Added 32KHz Oscillator/Xtal options on XTAL_32KHz P & N pins

Revision 1.1

- 1) Added Microwave Co-Axial connector with Switch
- 2) Added Fractus Antenna
- 3) SP3T Switch Controll 1 & 3 Interchaged
- 4) J2 U.FL Connector Removed
- 5) J4 & J5 Connectors Part no.changed to AXK6S60647YG(Panasonic)
- 6) R3 Removed & POC_OUT connected to J5 .B26
- 7) J4 & J5 Connectors Part no.changed to DF17(4.0)-60DP-0.5V(57)(Hirose)
- 8) J3, J4 , J5 References changed to J4 , J2, J3 respectively

Revision 1.0

- 1) Initial Version Schematics

Silicon Labs Confidential

 400 W Cesar Chavez Austin, TX 78701		
SILICON LABS		
Size	Title	
	RS9116X-SB-EVK1- Daughter Board	
Part Number	Document Number	Rev
<Part Number>	Revision	1.5
Date:	Thursday, September 24, 2020	Sheet 4 of 4