

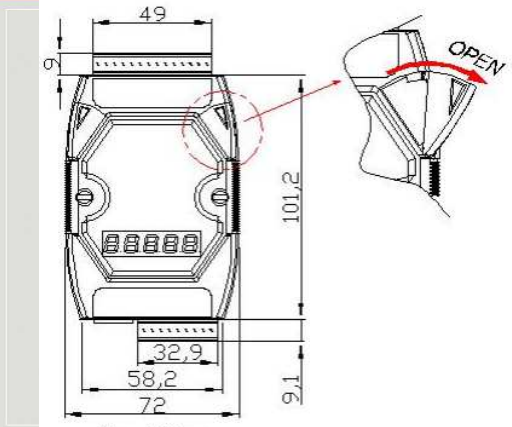

Remote Maintenance with serial streaming Solution



M2M-710D



Dimensions

The M2M-710D module is specially designed for the remote maintenance and upgrading the serial to network application solution. It is suitable for the harsh industrial field. M2M-710D provides 2 major technologies on networking. The Pair connection provides TCP data tunneling between 2 serial devices. M2M-710D also Support VxComm and VxServer functions that the maintenance man can take the remote maintenance or monitor whenever the time is and whatever the place is.

Features

- Provide pair connection (RS-232,RS-485) on network
- Web-based administration
- Support VxSoftware
- Support VxComm
- Accommodatingly with M-4132
- MiniOS 7
- Ethernet Protocol: TCP, UDP, IP, ICMP, AR
- Provide dynamic DNS function
- Built-in web server
- Built-in self-tuner ASIC chip for RS-485 port
- Quick start
- 5-Digit 7 Segment LED Display
- EMI, RoHS compliance
- Supply static IP/DHCP
- Supply DDNS(Dynamic DNS)

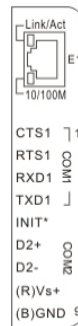

Pin	Name	Description
1	CTS1	Clear to Send
2	RTS1	Request to Send
3	RxD1	Receive Data
4	TxD1	Transmit Data
5	INIT	Init Pin
6	DATA+	Data+ of RS-485
7	DATA-	Data- of RS-485
8	Vs	Vs of Power Supply
9	GND	GND of Power Supply

Web-based administration

- The M2M-710D module built-in web server, the user can operate and set the module easily by web browser.

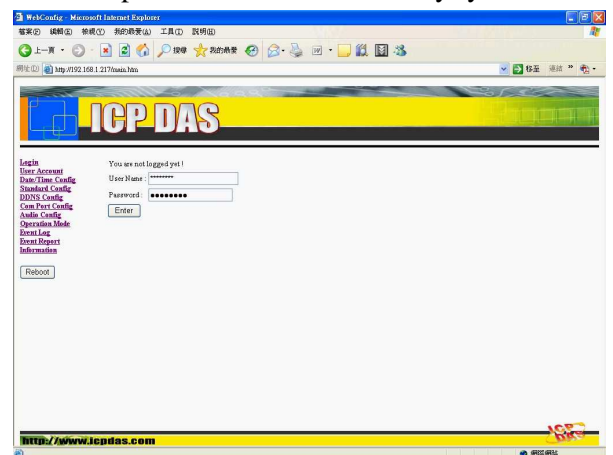

Pin Assignments



Hardware Specifications

Item	M2M-710D
CPU	80186-80 MHz or compatible
Flash	Flash ROM: 512 KB ; Erase unit is one sector (64 KB) ; 100,000 erase/write cycles
SDRAM	64M Bytes
SRAM	16 KB; Data retention: 40 years; 1,000,000 erase/write cycles.
Ethernet	10/100 Base-Tx, RJ-45 port (Auto-negotiating, auto MDI/MDI-X, LED indicator)
COM port	COM1: RS-232 interface -- D-sub5-write male RS-232: RxD,TxD,RTS,CTS,DTR,DSR,GND COM2: RS-485 interface -- 2-pin screw terminal block RS-485: RS-485(DATA+, DATA-), self-tuner ASIC inside Baud Rate : 1200/2400/4800/9600/19200/38400/57600/115200 bps Data Format: 7/8 data bits, None/Odd/Even parity bit, 1/2 stop bit
Power Requirement	10V ~ 30V
Power Consumption	2.5W
Operating Temp.	-20°C ~ +60°C
Storage Temp.	-25°C ~ +85°C
Dimensions	123 mm x 72 mm x 33 mm

Application

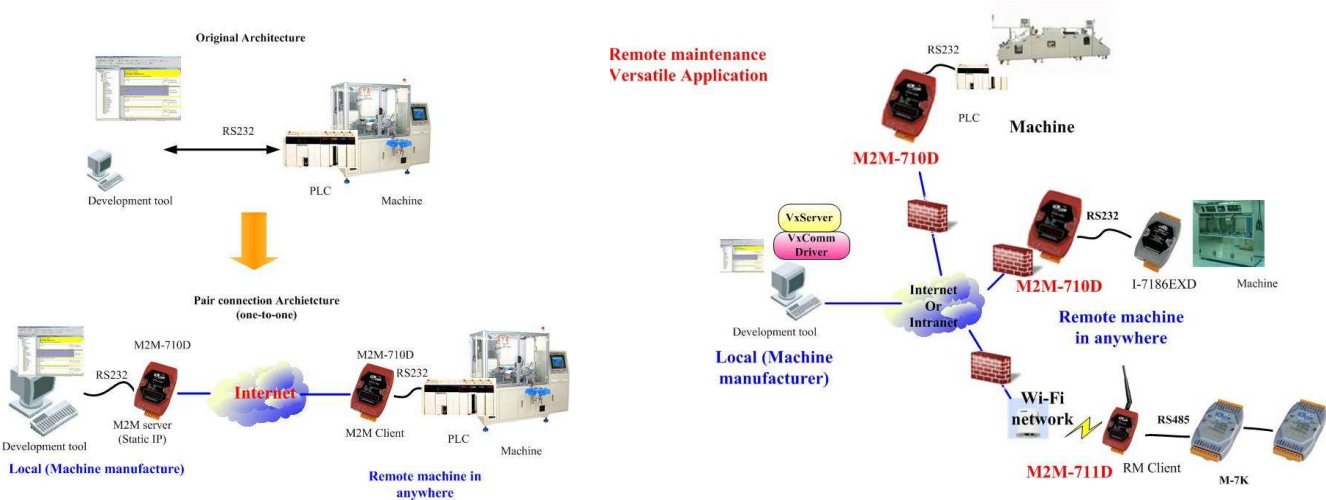

Ordering Information

M2M-710D

Remote Maintenance with serial streaming Solution