

Innovative and All-round General Purpose HT32

Provide customers with advantages of high integration and practicability, so as to achieve an excellent combination of power consumption, price and performance, with features that can assist customers to shorten the product development process and to quickly seize the market opportunities.



HT32 M0+ Series

The HT32 M0+ MCUs feature an excellent energy-efficient Arm® Cortex®-M0+ processor core, offering affordable price, low power consumption and sufficient performance. This makes the MCUs suitable for use in the Internet of Things (IoT), wearable device products and other similar applications. With the advantages in terms of code density, power consumption and price, the M0+ core-based MCUs are not only the first choice for new product design and development, but also the best choice for upgrading traditional products based on an 8-bit MCU to 32-bit MCU-based products with higher performance.

Major Advantages

- 32-bit Arm® Cortex®-M0+ processor core
- Up to 60 MHz operating frequency
- Up to 256 KB on-chip Flash memory and 32 KB on-chip SRAM
- Flash memory protection
- Multiple booting modes
- 24-bit SysTick timer
- ISP and IAP programming methods
- 3 power domains
- 12-bit SAR A/D converter with a conversion rate of up to 1 Msps
- Real time clock
- I²C, SPI, USART and USB interfaces
- Smart card interface
- Serial wire debug port

Core

- Arm® Cortex® -M0+ Processor
- Serial Wire Debug
- Internal Oscillators
- External Oscillators
- Real Time Clock
- Watchdog Timer
- System Clock
- PLL
- NVIC

Power Supply

- POR/PDR
- Backup Domain Power Management
- BOD/LVD

Interfaces

- SPI Master/Slave
- I²C Master/Slave
- USART Interface
- UART Interface
- USB Interface
- Smart Card Interface

HT32 Arm® Cortex®-M0+
Best Choice for
Affordable Price

Memory

- 16 ~ 256 KB Flash Memory
- 4 ~ 32 KB SRAM
- Multiple Booting Modes
- Flash Memory Protection
- IAP and ISP Programming Methods

Peripherals

- General Purpose Timer
- PWM Generator
- General Purpose Input/Output Ports
- Reset Control Unit
- Motor Control Timer
- Cyclic Redundancy Check
- Peripheral Direct Memory Access

Analog Features

- A/D Converter
- Comparator



HT32 M3 Series

The Holtek HT32 M3 core series of MCUs are based on the Arm® Cortex®-M3 processor, with features of advanced performance, reasonable price and low power consumption. This series is suitable for many applications such as automotive systems, industrial control systems, wireless networks and sensors, etc., which require a 32-bit MCU solution of high performance, low-dynamic and static power consumption specifications. Features such as configurable interrupts and memory protection provide even more outstanding performance and flexibility for this series of MCUs.

Major Advantages

- 32-bit Arm® Cortex®-M3 processor core
- Up to 96 MHz operating frequency
- Up to 256 KB on-chip Flash memory and 128 KB on-chip SRAM
- Flash memory protection
- Multiple booting modes
- 24-bit SysTick timer
- ISP and IAP programming methods
- 3 power domains
- 12-bit SAR A/D converter with a conversion rate of up to 1 Msp/s
- Real time clock
- I²C, SPI, USART and USB interfaces
- Smart card interface
- Serial wire debug port
- External Bus Interface

Core

- **Arm® Cortex®-M3 Processor**
- Serial Wire Debug
- Internal Oscillators
- External Oscillators
- Real Time Clock
- Watchdog Timer
- System Clock
- PLL
- NVIC

Power Supply

- POR/PDR
- Backup Domain Power Management
- BOD/LVD

Interfaces

- SPI Master/Slave
- I²C Master/Slave
- USART Interface
- UART Interface
- USB Interface
- Smart Card Interface
- **CMOS Sensor Interface**

HT32 Arm® Cortex®-M3
Advanced Performance and
Reasonable Price

Memory

- **16 ~ 256 KB Flash Memory**
- **16 ~ 128 KB SRAM**
- Multiple Booting Modes
- Flash Memory Protection
- IAP and ISP Programming Methods

Peripherals

- General Purpose Timer
- PWM Generator
- General Purpose Input/Output Ports
- Reset Control Unit
- Motor Control Timer
- Cyclic Redundancy Check
- Peripheral Direct Memory Access

Analog Features

- A/D Converter
- Comparator
- **Operational Amplifier**



HT32 M4 Series

The Holtek HT32 M4 core series is a high-performance solution based on the Arm® Cortex®-M4 processor. This series provides high performance and rich peripherals, making it an excellent choice for a wide range of applications such as industrial control, electric vehicle, etc. With abundant peripherals, high operating frequency, flexible power management and a large Flash memory capacity, this series of MCUs provides a powerful and performance-improved 32-bit MCU solution.

Major Advantages

- 32-bit Arm® Cortex®-M4 processor core
- Up to 240 MHz operating frequency
- Up to 1024 KB on-chip Flash memory and 224 KB on-chip SRAM
- Memory protection unit (MPU)
- Floating point unit (FPU) and DSP instructions
- Multiple booting modes
- 24-bit SysTick timer
- ISP and IAP programming methods
- External battery V_{BAT} pin
- 12-bit A/D converters and 12-bit D/A converters for high-performance analog interfacing
- I²C (SMBus / PMBus), SPI, I²S, USART/UART, SDIO, USB 2.0, CAN and IRTMR interfaces
- DMA for efficient data transfer between peripherals and memory
- Fast I/O and multi-functional bi-directional I/Os with 5 V tolerance
- Supports Compact Flash, SRAM, PSRAM, NOR and NAND memories and LCD parallel interface

Core

- **Arm® Cortex® -M4 Processor**
- Serial Wire Debug
- Internal Oscillators
- External Oscillators
- Real Time Clock
- Watchdog Timer
- System Clock
- PLL
- NVIC

Power Supply

- POR/PDR/PVM
- Battery Powered Domain
- V_{DD}/V_{DDA} Domain

Interfaces

- SPI Interface
- I²C Interface
- USART Interface
- UART Interface
- USB Interface
- **I²S Interface**
- **CAN Interface**
- **SDIO Interface**
- **IRTMR Interface**

HT32 Arm® Cortex®-M4
High Performance, Abundant
Peripherals and Interfaces

Memory

- **64 ~ 1024 KB Flash Memory**
- **32 ~ 224 KB SRAM**
- External Memory Controller (XMC)
- Multiple Booting Modes
- Memory Protection Unit
- IAP and ISP Programming Methods
- External Four-wire SPI Flash Memory Extension (SPIM)

Peripherals

- 16-bit Advanced-control Timer with Dead-time Generator and Emergency Brake
- 16-bit and 32-bit General Purpose Timers
- General Purpose Input / Output Ports
- Cyclic Redundancy Check
- Direct Memory Access (DMA)
- HICK Auto Clock Calibration
- 96-bit Unique ID (UID)

Analog Features

- A/D Converter
- D/A Converter
- **Temperature Sensor**

HT32 MCU Lineup for Wide Application Ranges M0+

Choosing a proper 32-bit MCU for your product application should focus not only on performance, but also on power consumption, package type, tooling, and cost. From the energy-efficient M0+ core series to the price and performance balanced M3 core series, then to the high-performance M4 core series, Holtek offers a wide range of flexible 32-bit MCU choices to meet your 32-bit application needs.

	16 KB	32 KB	64 KB	128 KB	256 KB	
5 V 16 MHz HT32F500xx	HT32F50020	HT32F50030				General Purpose
5 V 20 MHz HT32F502xx	HT32F50220	HT32F50230 HT32F50231	HT32F50241			
5 V 60 MHz HT32F504xx		HT32F50431	HT32F50441 HT32F50442	HT32F50452		
3.3 V 40 MHz HT32F522xx	HT32F52220	HT32F52230 HT32F52231	HT32F52241 HT32F52243	HT32F52253		
3.3 V 60 MHz HT32F522x4		HT32F52234	HT32F52244			
3.3 V USB 48 MHz HT32F523xx		HT32F52331	HT32F52341 HT32F52342	HT32F52352		USB
3.3 V USB 60 MHz HT32F523xx			HT32F52344	HT32F52354 HT32F52357	HT32F52367	
5 V USB 60 MHz HT32F503xx			HT32F50343			
3.3 V LCD 60 MHz HT32F573xx		HT32F57331	HT32F57341 HT32F57342	HT32F57352		LCD
5 V Touch 60 MHz HT32F542xx		HT32F54231	HT32F54241 HT32F54243	HT32F54253		Touch
5 V CAN 60 MHz HT32F532xx		HT32F53231	HT32F53241 HT32F53242	HT32F53252		CAN

Cortex®-M0+

HT32 MCU Lineup for Wide Application Ranges M3 M4

	32 KB	64 KB	128 KB	256 KB	1024 KB		
3.3 V 72 MHz HT32F123xx				HT32F12364		Cortex®-M3	USB
3.3 V 96 MHz HT32F123xx		HT32F12345		HT32F12365 HT32F12366			
3.3 V 150 MHz HT32F491x3			HT32F49153	HT32F49163		Cortex®-M4	USB
3.3 V 240 MHz HT32F493x5				HT32F49365	HT32F49395		



HT32 MCU Selection Guide

32-Bit Cortex®-M0+ MCU

32-Bit M0+ MCU

Part No.	Max. Freq.	VDD	Flash	SRAM	PDMA	ADC	DAC	Timer	RTC	Interface	Others	Max. I/O	Package
HT32F52220	40MHz	2.0V~3.6V	16KB	4KB	—	1MSPS 12-bit×8	—	BFTM×1, SCTM×2 GPTM×1	—	USART×1, UART×1 SPI×1, I ² C×1	—	23	24/28SSOP 33QFN
HT32F52230			32KB	4KB									
HT32F52231	40MHz	2.0V~3.6V	32KB	4KB	—	1MSPS 12-bit×12	—	BFTM×2, SCTM×4 GPTM×1, MCTM×1	√	USART×1, UART×2 SPI×2, I ² C×2	CRC	40	24/28SSOP 33QFN, 48LQFP
HT32F52241			64KB	8KB									
HT32F52234	60MHz	1.65V~3.6V	32KB	4KB	6CH	1MSPS 12-bit×12	500kSPS 12-bit×4	BFTM×2, SCTM×2 PWM×1	√	USART×1, UART×1 SPI×1, I ² C×3	CRC, DIV	40	24/28SSOP 24/32/46QFN, 48LQFP
HT32F52244			64KB	8KB									
HT32F52243	40MHz	2.0V~3.6V	64KB	8KB	6CH	1MSPS 12-bit×12	—	BFTM×2, SCTM×4 GPTM×1, MCTM×1	√	USART×2, UART×4 SPI×2, I ² C×3	CRC, DIV	52	33/46QFN 48/64LQFP
HT32F52253			128KB	16KB									

HT32F52234/HT32F52244 Operating Temperature: -40°C ~ 105°C

32-Bit M0+ USB MCU

Part No.	Max. Freq.	VDD	Flash	SRAM	PDMA	ADC	CMP	DAC	Timer	RTC	USB	Interface	Others	Max. I/O	Package
HT32F52331	48MHz	2.0V~3.6V	32KB	4KB	—	1MSPS 12-bit×12	—	—	BFTM×2, SCTM×4 GPTM×1, MCTM×1	√	√	USART×1, UART×2 SPI×2, I ² C×2	CRC, SCI	38	33QFN 48LQFP
HT32F52341			64KB	8KB											
HT32F52342	48MHz	2.0V~3.6V	64KB	8KB	6CH	1MSPS 12-bit×12	2	—	BFTM×2, SCTM×2 GPTM×2, MCTM×1	√	√	USART×2, UART×2 SPI×2, I ² C×2, I ² S×1	CRC, SCI	51	33QFN 48/64LQFP
HT32F52352			128KB	16KB											
HT32F52344	60MHz	1.65V~3.6V	64KB	8KB	6CH	1MSPS 12-bit×12	2	—	BFTM×2, SCTM×2 GPTM×1, MCTM×1	√	√	UART×2, SPI×2 I ² C×1	CRC, DIV EBI	54	33/46QFN 48/64LQFP
HT32F52354			128KB	8KB											
HT32F52357	60MHz	1.65V~3.6V	128KB	16KB	6CH	1MSPS 12-bit×12	2	500kSPS 12-bit×2	BFTM×2, SCTM×2 PWM×2, GPTM×1 MCTM×1	√	√	USART×2, UART×4, SPI×2 QSPI×1, I ² C×2, I ² S×1	CRC, DIV SCI, EBI, AES	67	46QFN 48/64/80LQFP
HT32F52367			256KB	32KB											

32-Bit M0+ USB LCD MCU

Part No.	Max. Freq.	VDD	Flash	SRAM	PDMA	ADC	CMP	DAC	Timer	RTC	USB	LCD	Interface	Others	Max. I/O	Package
HT32F57331	60MHz	1.65V~3.6V	32KB	4KB	—	1MSPS 12-bit×10	—	—	BFTM×2, PWM×2 GPTM×1	√	√	29×4~25×8	USART×1, UART×2 SPI×2, I ² C×2	CRC, DIV SCI	53	46QFN 48/64LQFP
HT32F57341			64KB	8KB												
HT32F57342	60MHz	1.65V~3.6V	64KB	8KB	6CH	1MSPS 12-bit×10	2	500kSPS 12-bit×2	BFTM×2, SCTM×2 PWM×2, GPTM×1	√	√	37×4~33×8	USART×1, UART×2 SPI×2, I ² C×2, I ² S×1	CRC, DIV SCI, AES	67	46QFN 48/64/80LQFP
HT32F57352			128KB	16KB												

32-Bit M0+ 5V MCU

Part No.	Max. Freq.	VDD	Flash	SRAM	PDMA	ADC	CMP	DAC	Timer	RTC	Interface	Others	Max. I/O	Package
HT32F50020	16MHz	2.5V~5.5V	16KB	2KB	—	500kSPS 12-bit×12	—	—	BFTM×1, SCTM×3	√	UART×2, SPI×1 I ² C×1	LEDC	42	24/28SSOP 24/32/46QFN, 48LQFP
HT32F50030			32KB	2KB										
HT32F50220	20MHz	2.5V~5.5V	16KB	4KB	—	1MSPS 12-bit×12	—	—	BFTM×1, PWM×2 GPTM×1	√	UART×2, SPI×2 I ² C×1	DIV	40	24/28SSOP 24/33/46QFN, 48LQFP
HT32F50230			32KB	4KB										
HT32F50231	20MHz	2.5V~5.5V	32KB	4KB	—	1MSPS 12-bit×12	—	—	BFTM×2, PWM×2 GPTM×1, MCTM×1	√	USART×1, UART×2 SPI×2, I ² C×2	CRC, DIV	40	24/28SSOP, 24/33/46QFN, 48LQFP
HT32F50241			64KB	8KB										
HT32F50431	60MHz	2.5V~5.5V	32KB	4KB	6CH	2MSPS 12-bit×12	—	—	BFTM×2, PWM×1 GPTM×1, MCTM×1	√	USART×1, UART×2 SPI×2, I ² C×2	CRC, DIV LEDC	40	32/46QFN 48LQFP
HT32F50441			64KB	8KB										
HT32F50442	60MHz	2.5V~5.5V	64KB	8KB	6CH	2MSPS 12-bit×12	2	—	BFTM×2, PWM×2 GPTM×1, MCTM×1	√	USART×2, UART×2 SPI×2, I ² C×2	CRC, DIV LEDC, EBI	54	32/46QFN 48/64LQFP
HT32F50452			128KB	16KB										

HT32F504xx Operating Temperature: -40°C ~ 105°C

32-Bit M0+ 5V USB MCU

Part No.	Max. Freq.	VDD	Flash	SRAM	PDMA	ADC	CMP	DAC	Timer	RTC	USB	Interface	Others	Max. I/O	Package
HT32F50343	60MHz	2.5V~5.5V	64KB	12KB	6CH	1MSPS 12-bit×12	—	—	BFTM×2, SCTM×2 8-PWM×3, GPTM×1	√	√	UART×2, SPI×2 I ² C×2, SLED×2	CRC, DIV	51	32/46QFN 48/64LQFP

32-Bit M0+ 5V CAN MCU

Part No.	Max. Freq.	VDD	Flash	SRAM	PDMA	ADC	CMP	DAC	Timer	RTC	CAN	Interface	Others	Max. I/O	Package
HT32F53231	60MHz	2.5V~5.5V	32KB	4KB	6CH	2MSPS 12-bit×12	—	—	BFTM×2, PWM×1 GPTM×1, MCTM×1	√	√	USART×1, UART×2 SPI×2, I ² C×2	CRC, DIV LEDC	40	32/46QFN 48LQFP
HT32F53241			64KB	8KB											
HT32F53242	60MHz	2.5V~5.5V	64KB	8KB	6CH	2MSPS 12-bit×12	2	—	BFTM×2, PWM×2 GPTM×1, MCTM×1	√	√	USART×2, UART×2 SPI×2, I ² C×2	CRC, DIV LEDC, EBI	54	32/46QFN 48/64LQFP
HT32F53252			128KB	16KB											

Operating Temperature: -40°C ~ 105°C

32-Bit M0+ 5V Touch MCU

Part No.	Max. Freq.	VDD	Flash	SRAM	PDMA	ADC	CMP	Timer	RTC	Touch Key	Interface	Others	Max. I/O	Package
HT32F54231	60MHz	2.5V~5.5V	32KB	4KB	—	1Msps 12-bit×10	—	BFTM×2, SCTM×2	√	24	USART×1, UART×2 SPI×2, I ² C×2	CRC, DIV LEDC	40	28SSOP, 32/46QFN 48LQFP
HT32F54241			64KB	8KB				GPTM×1, MCTM×1						
HT32F54243	60MHz	2.5V~5.5V	64KB	8KB	6CH	1Msps 12-bit×10	2	BFTM×2, SCTM×4	√	28	USART×2, UART×4 SPI×2, I ² C×3	CRC, DIV LEDC	54	32/46QFN 48/64LQFP
HT32F54253			128KB	16KB				GPTM×1, MCTM×1						

32-Bit M0+ 24-Bit A/D MCU

Part No.	Max. Freq.	VDD	Flash	SRAM	ADC	ENOB	Timers	Cap.or PWM	Cap. PWM	RTC	Interface	Others	Max. I/O	Package
HT32F59041	20MHz	2.5V~5.5V	64KB	8KB	12-bit×12	—	BFTM×2, PWM×2 GPTM×1, MCTM×1	16	3	√	USART×1, UART×2 SPI×1, I ² C×1	CRC, DIV	30	48LQFP
					24-bit×4	19.5								

32-Bit M0+ 24-Bit A/D LCD MCU

Part No.	Max. Freq.	VDD	Flash	SRAM	ADC	ENOB	Timers	Cap.or PWM	RTC	SCI	USB	LCD	Interface	Others	Max. I/O	Package
HT32F59741	60MHz	1.65V~3.6V	64KB	8KB	12-bit×10	—	BFTM×2, PWM×2 GPTM×1	12	√	1	√	29×4 ~ 25×8	USART×1, UART×2 SPI×2, I ² C×2	CRC, DIV	43 53	64/80LQFP
					24-bit×4	19.5										

Body Fat Measurement Cortex®-M0+ 32-Bit Flash MCU

Part No.	Max. Freq.	VDD	Flash	SRAM	I/O	RTC	Timer	LCD	ADC	Electrode	Phase Detect	Interface	Package
HT32F59046	20MHz	2.5V~5.5V	64KB	8KB	38	√	BFTM×2, PWM×2 GPTM×1, MCTM×1	—	12-bit×12	8	√	USART×1, UART×2 SPI×2, I ² C×2	64LQFP
HT32F59746	60MHz	2.2V~3.6V			51	√	BFTM×2, PWM×2 GPTM×1	29×4 27×6 25×8	12-bit×4			80LQFP	
			24-bit×4	I ² C×2, SCI×1									

Note:
 BFTM: Basic Function Timer
 GPTM: General Purpose Timer
 QSPI: Quad serial peripheral interface
 SCI: Smart Card Interface
 AES: Advanced Encryption Standard
 SCTM: Single Channel Timer
 MCTM: Motor Control Timer
 SLED: Strip LED Controller
 LEDC: LED controller
 PWM: Pulse Width Modulation
 USB: 2.0 Full Speed device
 DIV: Hardware Divider
 EBI: External Bus Interface for NOR Flash/SRAM/LCD

32-Bit Cortex®-M3 MCU

32-Bit M3 USB MCU

Part No.	Max. Freq.	VDD	Flash	SRAM	PDMA	ADC	CMP	Timer	RTC	USB	Interface	Others	Max. I/O	Package
HT32F12345	96MHz	2.0V~3.6V	64KB	16KB	12CH	1Msps 12-bit×12	2	BFTM×2, GPTM×2 MCTM×2	√	√	USART×2, UART×2 SPI×2, I ² C×2, I ² S×1	CRC, EBI SDIO	51	46QFN 48/64LQFP
HT32F12365	96MHz	2.0V~3.6V	256KB	64KB	12CH	1Msps 12-bit×16	2	BFTM×2, GPTM×2 MCTM×2	√	√	USART×2, UART×2 SPI×2, I ² C×2, I ² S×1	CRC, SCI EBI, AES, SDIO	80	46QFN 48/64/100LQFP
HT32F12366			256KB	128KB										
HT32F22366	96MHz	2.0V~3.6V	256KB	128KB	12CH	1Msps 12-bit×16	2	BFTM×2, GPTM×2 MCTM×2	√	√	USART×2, UART×2 SPI×2, I ² C×2, I ² S×1	CRC, SCI, EBI AES, SDIO, CSIF	80	46QFN 48/64/100LQFP
HT32F12364	72MHz	1.65V~3.6V	256KB	128KB	6CH	1Msps 12-bit×8	—	BFTM×2, SCTM×2 PWM×1, GPTM×1	√	√	USART×1, UART×2 SPI×2, I ² C×2	CRC, SCI EBI, AES	52	40QFN 48/64LQFP

Note:
 BFTM: Basic Function Timer
 GPTM: General Purpose Timer
 AES: Advanced Encryption Standard
 SCTM: Single Channel Timer
 MCTM: Motor Control Timer
 SDIO: Secure Digital Input Output
 PWM: Pulse Width Modulation
 SCI: Smart Card Interface
 CSIF: CMOS Sensor Interface

32-Bit Cortex®-M4 MCU

32-Bit M4 USB MCU

Part No.	Max. Freq.	VDD	Flash	SRAM	DMA	ADC	DAC	Timer	RTC	USB	CAN	Interface	Others	Max. I/O	Package
HT32F49153	150MHz	2.4V~3.6V	128KB	48KB	7CH×2	5.33Msps 12-bit×24	12-bit×2	WWDT×1, BTMR×2	√	FS OTG	2	USART×8, SPI×3 S×3, I ² C×3	CRC, XMC, IRTMR	87	32QFN 48/64/100LQFP
HT32F49163			256KB	48KB				GPTMR×9, ACTMR×1							
HT32F49365	240MHz	2.6V~3.6V	256KB	224KB	7CH×2	2Msps 12-bit×16×3	12-bit×2	WWDT×1, BTMR×2	√	FS Device	2	USART×4, UART×4 SPI/I ² S×4, I ² C×3	CRC, SPIM, XMC, SDIO	80	48QFN 48/64/100LQFP
HT32F49395			1024KB					GPTMR×10, ACTMR×2							

Operating Temperature: -40°C ~ 105°C
 Note:
 WWDT: Window Watchdog Timer
 ACTMR: Advanced Control Timer
 IRTMR: Infrared Transmitter
 BTMR: Basic Timer
 SPIM: External SPI Flash Memory Extension
 SDIO: Secure Digital Input Output
 GPTMR: General Purpose Timer
 XMC: External Memory Controller.

Package Size

	24 SSOP	28 SSOP	28 SOP		
					
Size	3.9 × 8.6 mm	3.9 × 9.9 mm	7.5 × 17.9 mm		
Lead Pitch	0.64 mm	0.64 mm	1.27 mm		
Thickness	1.75 mm	1.75 mm	2.65 mm		

	24 QFN	32/33 QFN	40 QFN	46 QFN	48 QFN
					
Size	3.0 mm	4.0 mm	5.0 mm	4.5 × 6.5 mm	6.0 mm
Lead Pitch	0.40 mm	0.40 mm	0.40 mm	0.40 mm	0.40 mm
Thickness	0.55 mm	0.75 mm	0.75 mm	0.75 mm	0.85 mm

	44 LQFP	48 LQFP	64 LQFP	80 LQFP	100 LQFP
			 		
Size	10.0 mm	7.0 mm	7.0 / 10.0 mm	10.0 mm	14.0 mm
Lead Pitch	0.80 mm	0.50 mm	0.40 / 0.50 mm	0.40 mm	0.50 mm
Thickness	1.60 mm	1.60 mm	1.60 / 1.60 mm	1.60 mm	1.60 mm

HT32 Family – Naming Rule

HT32 F x xx x x

Product Family

HT32 = Holtek 32-bit MCU

Product Type

F = Flash MCU

Product Core

- 1 = Cortex®-M3 Standard MCU
- 2 = Cortex®-M3 ASSP MCU
- 4 = Cortex®-M4 Standard MCU
- 5 = Cortex®-M0+ Standard MCU
- 6 = Cortex®-M0+ ASSP MCU
- 7 = Cortex®-M0+ Standard MCU
- 8 = Cortex®-M0+ ASSP MCU

Product Series

- 123 = 3.3 V, USB
- 491 = 3.3 V, USB
- 493 = 3.3 V, USB
- 500 = 5.0 V, General
- 502 = 5.0 V, General
- 503 = 5.0 V, USB
- 504 = 5.0 V, General
- 522 = 3.3 V, General
- 523 = 3.3 V, USB
- 532 = 5.0 V, CAN
- 542 = 5.0 V Touch
- 573 = 3.3 V, LCD
- 590 = 5.0 V, General + 24-bit ADC
- 597 = 3.3 V, LCD + 24-bit ADC

Marketing Name

Functional Category :
Serial number 0 ~ 9

Flash Capacity

- 1 = 8 KB
- 2 = 16 KB
- 3 = 32 KB
- 4 = 64 KB
- 5 = 128 KB
- 6 = 256 KB
- 7 = 384 KB
- 8 = 512 KB
- 9 = 1024 KB

HT32 MCU Development Tools

Good MCU development tools are a necessary requirement for any design process. In order to support the Holtek 32-bit M0+, M3 and M4 core series of MCUs, Holtek and its external vendors offer a complete set of software and hardware tools to assist users with easy prototyping and debugging. Holtek's starter kit contains all the basic hardware, including an embedded e-Link32 Pro that provides a simple connection to a PC, allowing users to develop products quickly.

Holtek's expansion boards contain a variety of common electronic components such as switches, LEDs, potentiometer buzzers, IR components, etc., providing a flexible and complete system to ensure that users can quickly and easily learn how to use Holtek's 32-bit MCUs. A complete software library and comprehensive graphic documents ensure that customers can quickly develop 32-bit MCU-based products.

 Holtek development tools can be purchased at Best Modules online shop

Development Resources

Development Resources	Firmware Library	Development Environment
<ul style="list-style-type: none"> Support multiple development environments and free Keil (Cortex®-M0+ series) HT32 firmware, application examples Datasheet, user manuals, application notes ISP/IAP/Writer tools 	 <ul style="list-style-type: none"> Peripheral Drivers Examples Board Support Driver 	   

USB Debug Adapter

HT32 series online debug / programming tool



Type	Features
e-Link32 Pro	Arm® SWD USB debug adapter for the HT32 MCUs, CMSIS-DAP compliant.

Starter Kit

MCU I/O target board for prototyping, including an on-chip USB debug adapter

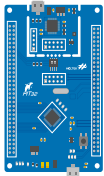

M0+ Series	Type	M0+ Series	Type
HT32F52342/52352	ESK32-30501	HT32F54231/54241	ESK32-30518
HT32F52331/52341	ESK32-30502	HT32F54243/54253	ESK32-30519
HT32F52231/52241	ESK32-30503	HT32F50020/50030	ESK32-30520
HT32F52220/52230	ESK32-30504		
HT32F52243/52253	ESK32-30505	M3 Series	Type
HT32F50220/50230	ESK32-30506	HT32F12365/12366	ESK32-30105
HT32F50231/50241	ESK32-30507	HT32F12345	ESK32-30106
HT32F52344/52354	ESK32-30509	HT32F12364	ESK32-30107
HT32F52357/52367	ESK32-30510		
HT32F57342/57352	ESK32-30511	M4 Series	Type
HT32F57331/57341	ESK32-30512	HT32F49365/49395	ESK32-31401
HT32F50343	ESK32-30515		

Expansion Boards

Functional extension of starter kit

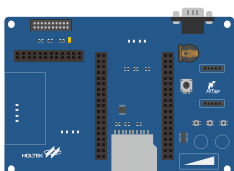

Type	Features
ESK32-20001 ESK32-20001A	<p>The basic expansion board is designed for use with the ESK-30xxx series of starter kits. Expansion board functions include:</p> <ul style="list-style-type: none"> User interfaces: 8080/SPI LCD connectors, buzzer, LEDs, potentiometer, keys, touch keys Communication: RS232 and multiple interfaces for module expansion Storage: EEPROM, SPI Flash, SD card slot
ESK32-21001 ESK32-21001A	Enhanced version of expansion board with added functions such as smart card connector, audio encoder/decoder, CMOS sensor interface, etc.

Note: These expansion boards are not supported for use with the M4 series ESK32-31xxx starter kit.

HT32 MCU Programming Methods

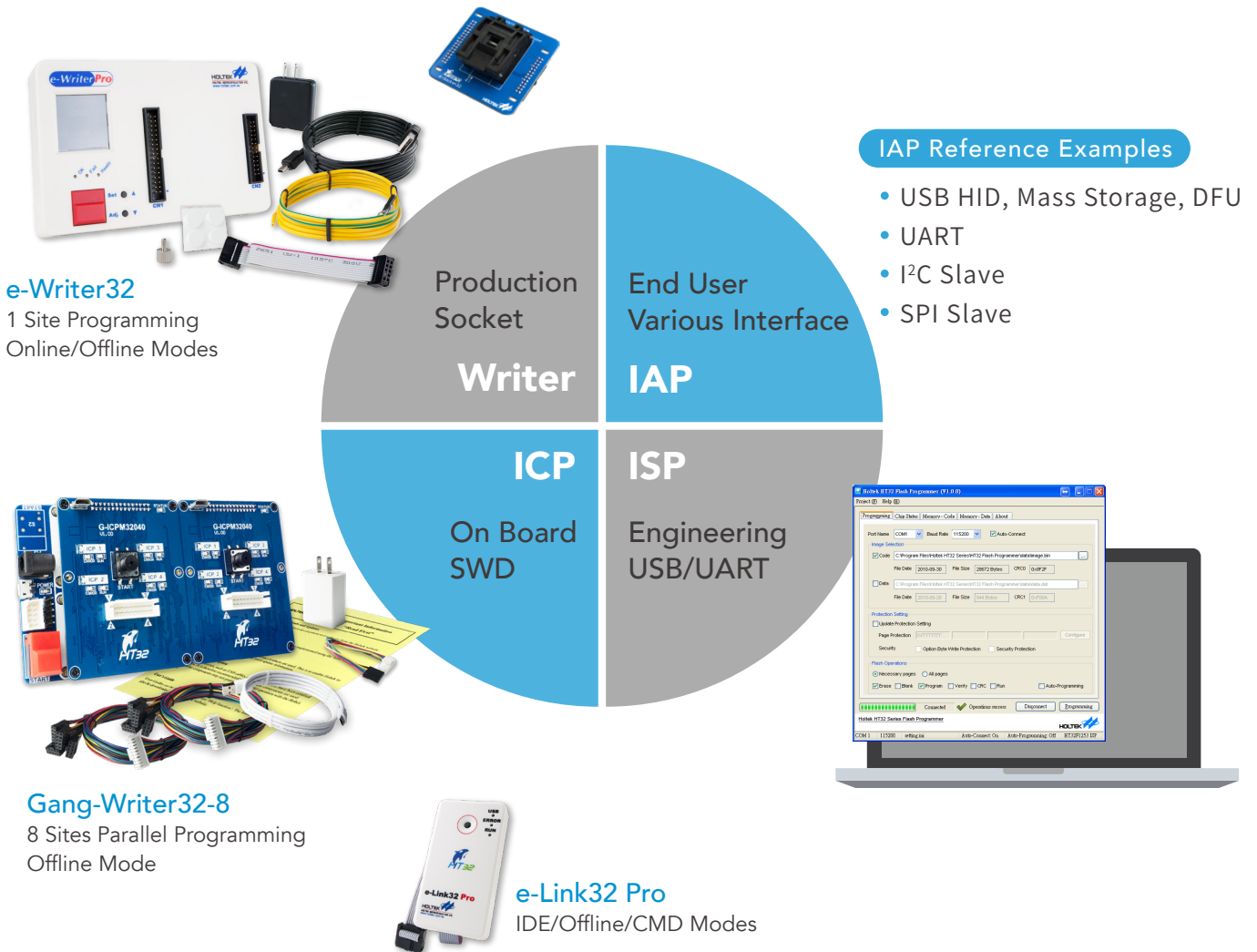

HT32 MCU Development Resources and Download Website

The development resources include datasheet, reference documents, schematics, HT32 firmware library, PC driver, tools, etc.

Resource Download

<https://mcu.holtek.com/ht32/resource/> 



HT32F5 Series (Cortex[®]-M0+)
HT32_M0p_vxxxxxxxx.zip

HT32F1 Series (Cortex[®]-M3)
HT32_M3_vxxxxxxxx.zip

Application Products

Smart Home

More and more household appliances such as smart and connection type of products require 32-bit processing.

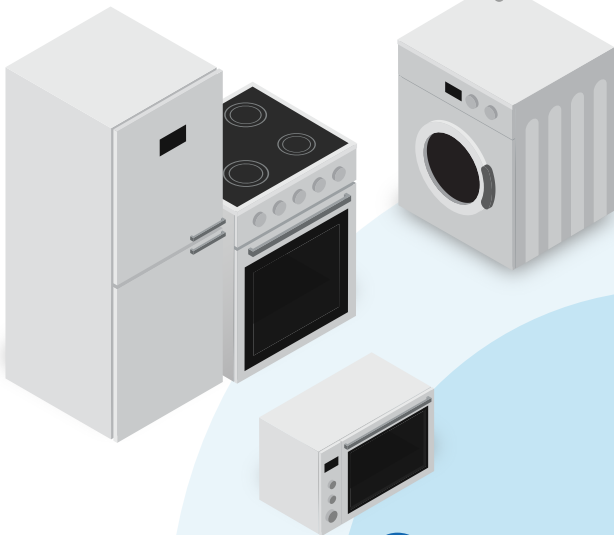

IoT/Wearable Devices

The demand for a low power consumption 32-bit MCU in wearable devices is growing.



USB Peripherals

USB is still the most versatile interface and an essential feature of PC-related products.



Smart Products HT32 MCU Solutions

Power Applications

Use a 32-bit MCU for better control and computing capability.



Intelligent Leisure Products

Higher-level leisure products require a 32-bit MCU in terms of computing power and cost efficiency.

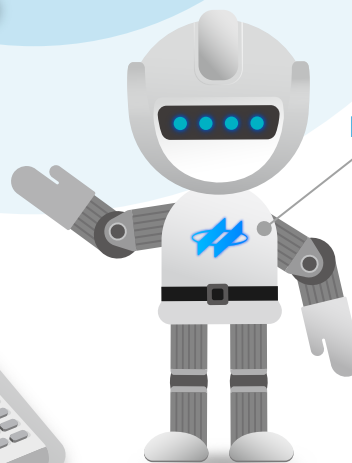

Data Processors/Recorders

32-bit processing capabilities are required for enhanced data processing.



■ HT32F65x40 Series

Focusing on the 2-shunt FOC systems, this series has IEC/UL 60730-1 motor software certification and therefore can be quickly introduced into motor products with UL requirements.

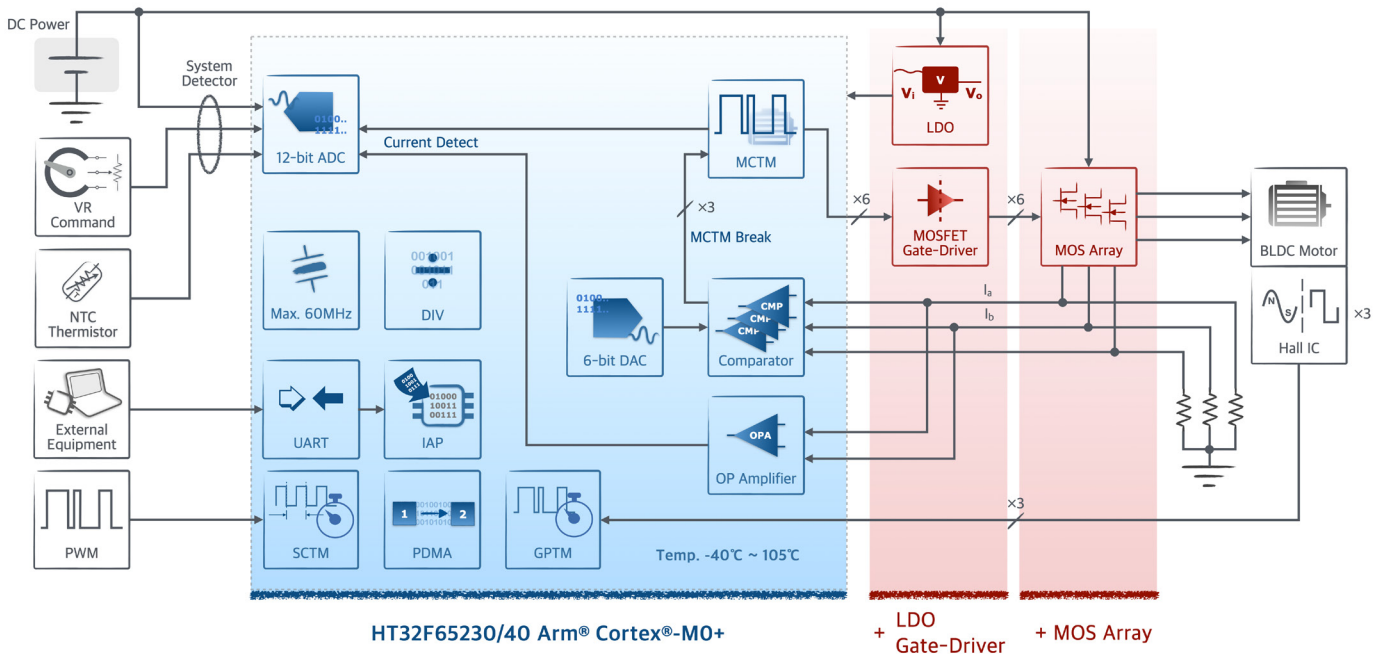

■ HT32F66x46 Series

This is the latest generation which not only focuses on the 3-shunt FOC systems but also can be compatible with the 1-2-shunt FOC systems. The maximum system frequency is increased to 80 MHz. The 2.5 Msps ADC, hardware CORDIC and PID engine combined can effectively shorten the calculation time. The amplifier has integrated gain and DC offset circuit, reducing the peripheral circuitry. The integration of CAN bus and LIN bus allows for more abundant communication options, making the devices ideal for use in electric vehicles.

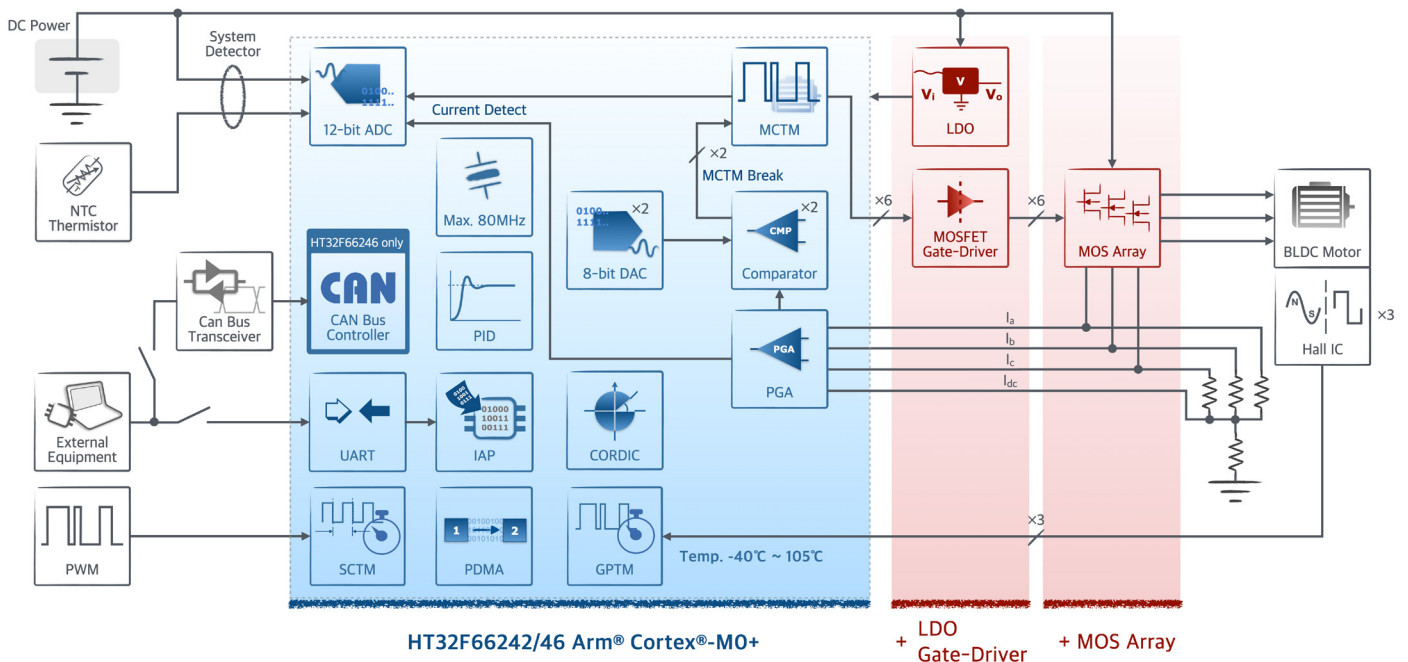

All series support FOC Hall or sensorless control. An HT32 BLDC Motor Workshop platform is also provided with real-time parameter adjustment, control and monitoring, which can assist customers to run the motor smoothly in a short time, and then achieve a product solution through the secondary development software. After this the product can be introduced into mass production and promoted into the market in the first time. A variety of introduction and mass production results have been achieved, such as ceiling fans, floor fans, electric scooters and racing bikes, hair dryers, range hoods, pumps, exhaust fans in addition to many others.

Arm® Cortex®-M0+ BLDC Motor Control Purpose Selection Guide

BLDC Motor MCU

Cortex®-M0+ 32-Bit BLDC Motor MCU																
Part No.	Max. Freq.	VDD	Flash	SRAM	PDMA	ADC	CMP	OPA / PGA	Timer ¹	Cap. ² or PWM	Cpm. PWM ³	RTC	Interface	Others	I/O	Package
HT32F65232	60MHz	2.5V~5.5V	32KB	4KB	6CH	2Msps×1 12-bit×12	2	1 / 0	BFTM×2 SCTM×4 GPTM×1 MCTM×1 LSTM×1	12	3	—	USART×1 UART×1 SPI×1, I ² C×1	CRC DIV	20 28 44	24SSOP 32QFN 48LQFP
HT32F65230			64KB	8KB		1Msps×2 12-bit×8	3	2 / 0	BFTM×2 SCTM×4 GPTM×1 MCTM×1			√			40	48LQFP
HT32F65240																
Cortex®-M0+ 32-Bit BLDC Motor MCU (CORDIC + PID Engine)																
HT32F66242*	80MHz	2.5V~5.5V	64KB	8KB	6CH	2.5Msps×1 12-bit×12	2	0 / 4	BFTM×2 SCTM×4 GPTM×1 MCTM×1 LSTM×1	12	3	—	USART×1 UART×1 SPI×1, I ² C×1	CRC DIV	20 28 44	24SSOP 32QFN 48LQFP
HT32F66246													CAN Bus x1 USART×1 UART×1 SPI×1, I ² C×1			

* Under development, available in 1Q, 2024.
 Note: 1. BFTM: Basic Function Timer, SCTM: Single-Channel Timer, GPTM: General-Purpose Timer, MCTM: Motor Control Timer, LSTM: Low Speed Timer.
 2. Cap.: Input Capture.
 3. Cpm. PWM: Complementary PWM for 3-phase motor control or inverter application.

BLDC Motor MCU with Gate-Driver

Cortex®-M0+ 32-Bit BLDC Motor MCU with 36V P/N Gate-Driver																	
Part No.	Max. Freq.	VCC	LDO	Flash	SRAM	PDMA	ADC	CMP	OPA / PGA	Timer ²	Cap. ³ or PWM	Cpm. PWM ⁴	RTC	Interface	Others	I/O	Package
HT32F65432A	60MHz	6V~32V	5V ¹	32KB	4KB	6CH	2Msps×1 12-bit×12	2	1 / 0	BFTM×2 SCTM×4 GPTM×1 MCTM×1 LSTM×1	12	3	—	USART×1 UART×1 SPI×1, I ² C×1	CRC DIV	16 29 34	32QFN 48LQFP-EP 64LQFP-EP
HT32F65440A				64KB	8KB		1Msps×2 12-bit×8	3	2 / 0	BFTM×2 SCTM×4 GPTM×1 MCTM×1 LSTM×1						28 34	48LQFP-EP 64LQFP-EP
Cortex®-M0+ 32-Bit BLDC Motor MCU with 36V P/N Gate-Driver (CORDIC + PID Engine)																	
HT32F66442A*	80MHz	6V~32V	5V ¹	64KB	8KB	6CH	2.5Msps×1 12-bit×12	2	0 / 4	BFTM×2 SCTM×4 GPTM×1 MCTM×1 LSTM×1	12	3	—	USART×1 UART×1 SPI×1, I ² C×1	CRC DIV	16 31 36	32QFN 48LQFP-EP 64LQFP-EP
HT32F66446A														CAN Bus x1 USART×1 UART×1 SPI×1, I ² C×1		16 31 36	32QFN 48LQFP-EP 64LQFP-EP
Cortex®-M0+ 32-Bit BLDC Motor MCU with 48V N/N Gate-Driver																	
HT32F65532G	60MHz	6V~40V	5V	32KB	4KB	6CH	2Msps×1 12-bit×12	2	1 / 0	BFTM×2 SCTM×4 GPTM×1 MCTM×1 LSTM×1	12	3	—	USART×1 UART×1 SPI×1, I ² C×1	CRC DIV	12 28 34	32QFN 48LQFP-EP 64LQFP-EP
HT32F65540G				64KB	8KB		1Msps×2 12-bit×8	3	2 / 0	BFTM×2 SCTM×4 GPTM×1 MCTM×1 LSTM×1						26 34	48LQFP-EP 64LQFP-EP
Cortex®-M0+ 32-Bit BLDC Motor MCU with 48V N/N Gate-Driver (CORDIC + PID Engine)																	
HT32F66542G*	80MHz	6V~40V	5V	64KB	8KB	6CH	2.5Msps×1 12-bit×12	2	0 / 4	BFTM×2 SCTM×4 GPTM×1 MCTM×1 LSTM×1	12	3	—	USART×1 UART×1 SPI×1, I ² C×1	CRC DIV	12 28 36	32QFN 48LQFP-EP 64LQFP-EP
HT32F66546G														CAN Bus x1 USART×1 UART×1 SPI×1, I ² C×1		12 28 36	32QFN 48LQFP-EP 64LQFP-EP
Cortex®-M0+ 32-Bit BLDC Motor MCU with 110V N/N Gate-Driver																	
HT32F65732G	60MHz	6V~20V	5V	32KB	4KB	6CH	2Msps×1 12-bit×12	2	1 / 0	BFTM×2 SCTM×4 GPTM×1 MCTM×1 LSTM×1	12	3	—	USART×1 UART×1 SPI×1, I ² C×1	CRC DIV	22 26 36	46QFN 48LQFP-EP 64LQFP-EP
HT32F65740G				64KB	8KB		1Msps×2 12-bit×8	3	2 / 0	BFTM×2 SCTM×4 GPTM×1 MCTM×1 LSTM×1						24 34	48LQFP-EP 64LQFP-EP

Cortex®-M0+ 32-Bit BLDC Motor MCU with 110V N/N Gate-Driver (CORDIC + PID Engine)																	
Part No.	Max. Freq.	VCC	LDO	Flash	SRAM	PDMA	ADC	CMP	OPA / PGA	Timer ²	Cap. ³ or PWM	Cpm. PWM ⁴	RTC	Interface	Others	I/O	Package
HT32F66742G*	80MHz	6V~20V	5V	64KB	8KB	6CH	1Msps×2 12-bit×12	3	0 / 4	BFTM×2 SCTM×4 GPTM×1 MCTM×1 LSTM×1	12	3	—	USART×1	CRC DIV	23	46QFN
HT32F66746G														UART×1		26	48LQFP-EP
														CAN Bus x1		26	46QFN
														UART×1		26	48LQFP-EP
														SPI×1, I ² C×1		36	64LQFP-EP

* Under development, available in 1Q, 2024.
 Note: 1. LDO: Support external signal wakeup to realize zero standby power function.
 2. BFTM: Basic Function Timer, SCTM: Single-Channel Timer, GPTM: General-Purpose Timer, MCTM: Motor Control Timer, LSTM: Low Speed Timer.
 3. Cap.: Input Capture.
 4. Cpm. PWM: Complementary PWM for 3-phase motor control or inverter application.

BLDC Motor MCU with Driver

Cortex®-M0+ 32-Bit BLDC Motor MCU with Driver																	
Part No.	Max. Freq.	VM	LDO	Peak Current	Flash	SRAM	PDMA	ADC	CMP	OPA / PGA	Timer ¹	Cap. ² or PWM	Cpm. PWM ³	Interface	Others	I/O	Package
HT32F65C32F	60MHz	6V~32V	5V	3.5A	32KB	4KB	6CH	2Msps×1 12-bit×12	2	1 / 0	BFTM×2 SCTM×4 GPTM×1 MCTM×1 LSTM×1	12	3	USART×1 UART×1 SPI×1 I ² C×1	CRC DIV	28	48LQFP-EP
HT32F65C40F					64KB	8KB		1Msps×2 12-bit×8	3	2 / 0	BFTM×2 SCTM×4 GPTM×1 MCTM×1 LSTM×1					26	48LQFP-EP

Cortex®-M0+ 32-Bit BLDC Motor MCU with Driver (CORDIC + PID Engine)																	
Part No.	Max. Freq.	VCC	LDO	Peak Current	Flash	SRAM	PDMA	ADC	CMP	OPA / PGA	Timer ¹	Cap. ² or PWM	Cpm. PWM ³	Interface	Others	I/O	Package
HT32F66C42F*	80MHz	6V~32V	5V	3.5A	64KB	8KB	6CH	2.5Msps×1 12-bit×12	2	0 / 4	BFTM×2 SCTM×4 GPTM×1 MCTM×1 LSTM×1	12	3	USART×1 UART×1 SPI×1 I ² C×1	CRC DIV	27 34	48LQFP-EP 64LQFP-EP

* Under development, available in 1Q, 2024.
 Note: 1. BFTM: Basic Function Timer, SCTM: Single-Channel Timer, GPTM: General-Purpose Timer, MCTM: Motor Control Timer, LSTM: Low Speed Timer.
 2. Cap.: Input Capture.
 3. Cpm. PWM: Complementary PWM for 3-phase motor control or inverter application.

BLDC Motor Workshop

 Holtek Official Reference

The HT32 BLDC Motor Workshop provides complete hardware, FOC algorithm libraries and PC-side software to help users shorten the development period of 3-phase BLDC motor products and lower the technical threshold for entering the BLDC motor area.

BLDC Motor Control Development Boards

 Best Modules Online Shop

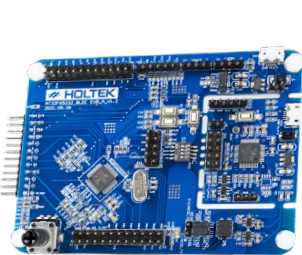

EVB

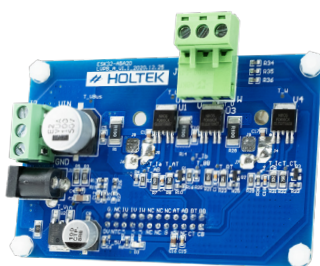

LVPB
9 ~ 26 V / 2.5 A

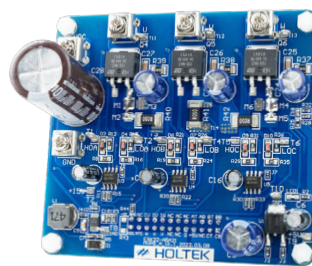

MVPB
15 ~ 60 V / 20 A



HVPB
AC 90 ~ 260 V / 2.5 A

HT32 High Accuracy Measurement Applications

24-bit Delta Sigma ADC for high accuracy measurements



Holtek has released its new Arm® Cortex®-M0+ MCUs, the HT32F59xxx series, which are specially designed for high accuracy measurement applications. The integrated A/D converter has an Effective Number of Bits (ENOB) of up to 19.5 and has a conversion rate of up to 1.6 kHz, which combined with the 12-bit SAR A/D converter that has a conversion rate of 1 MHz, allows users to implement fast and accurate measurements. Other resources include an LCD display driver, USB, UART and other commonly used serial transmission interfaces. These make the devices suitable for a diversified range of applications including electronic scales, blood pressure meters, thermometers, high accuracy industrial controls or instrumentation etc.

High Accuracy Measurement Application Block Diagram

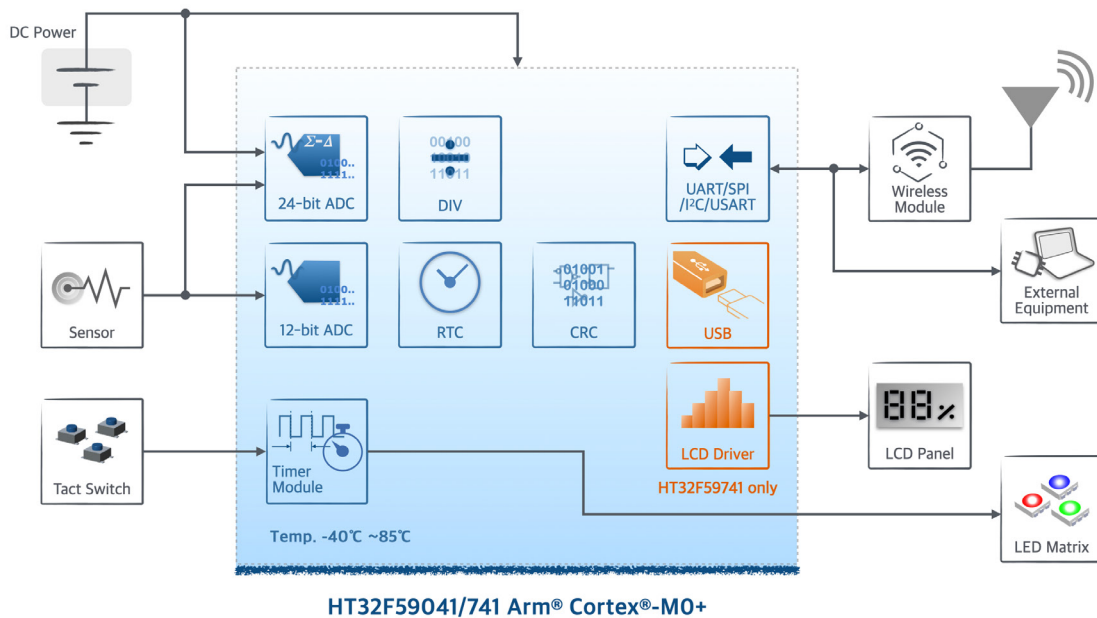

Arm® Cortex®-M0+ High Accuracy Measurement Purpose Selection Guide

32-Bit M0+ 24-Bit A/D MCU																
Part No.	Max. Freq.	VDD	Flash	SRAM	ADC	ENOB	Timers	Cap.or PWM	Cap. PWM	RTC	Interface	Others	Max. I/O	Package		
HT32F59041	20MHz	2.5V~5.5V	64KB	8KB	12-bit×12	—	BFTM×2, PWM×2 GPTM×1, MCTM×1	16	3	√	USART×1, UART×2 SPI×1, I²C×1	CRC, DIV	30	48LQFP		
					24-bit×4										19.5	
32-Bit M0+ 24-Bit A/D LCD MCU																
Part No.	Max. Freq.	VDD	Flash	SRAM	ADC	ENOB	Timers	Cap.or PWM	RTC	SCI	USB	LCD	Interface	Others	Max. I/O	Package
HT32F59741	60MHz	1.65V~3.6V	64KB	8KB	12-bit×10	—	BFTM×2, PWM×2 GPTM×1	12	√	1	√	29×4 ~ 25×8	USART×1, UART×2 SPI×2, I²C×2	CRC, DIV	43 53	64/80LQFP
					24-bit×4											
Body Fat Measurement Cortex®-M0+ 32-Bit Flash MCU																
Part No.	Max. Freq.	VDD	Flash	SRAM	I/O	RTC	Timer	LCD	ADC	Electrode	Phase Detect	Interface	Package			
HT32F59046	20MHz	2.5V~5.5V	64KB	8KB	38	√	BFTM×2, PWM×2 GPTM×1, MCTM×1	—	12-bit×12	8	√	USART×1, UART×2 SPI×2, I²C×2	64LQFP			
									24-bit×4							
HT32F59746	60MHz	2.2V~3.6V	64KB	8KB	51	√	BFTM×2, PWM×2 GPTM×1	29×4 27×6 25×8	12-bit×4	8	√	USART×1 UART×2, SPI×2 I²C×2, SCI×1	80LQFP			
								24-bit×4								

Note:
 BFTM: Basic Function Timer
 GPTM: General Purpose Timer
 QSPI: Quad serial peripheral interface
 SCI: Smart Card Interface
 AES: Advanced Encryption Standard
 SCTM: Single Channel Timer
 MCTM: Motor Control Timer
 SLED: Strip LED Controller
 LEDC: LED controller
 PWM: Pulse Width Modulation
 USB: 2.0 Full Speed device
 DIV: Hardware Divider
 EBI: External Bus Interface for NOR Flash/SRAM/LCD

Bluetooth Low Energy (BLE) Wireless Data Transmission Technology for Internet of Things (IoT)



Smart phones have led to the popularization of Bluetooth devices. Audio transmission is a larger Bluetooth peripheral application, followed by data transmission (e.g., wearable devices or healthcare) and location services (e.g., indoor guidance or dissemination of point-of-interest information). For the latter two applications, Holtek has released a BLE Arm® Cortex®-M0+ dual-core SoC MCU, the HT32F67741, which has passed the BLE5.2 BQB (Bluetooth Qualification Body) certification. The device is suitable for use in health care products, home appliances, beacons, intelligent leisure products, data loggers, human interface devices (HID) service, etc.

BT5.2 BLE Application Block Diagram

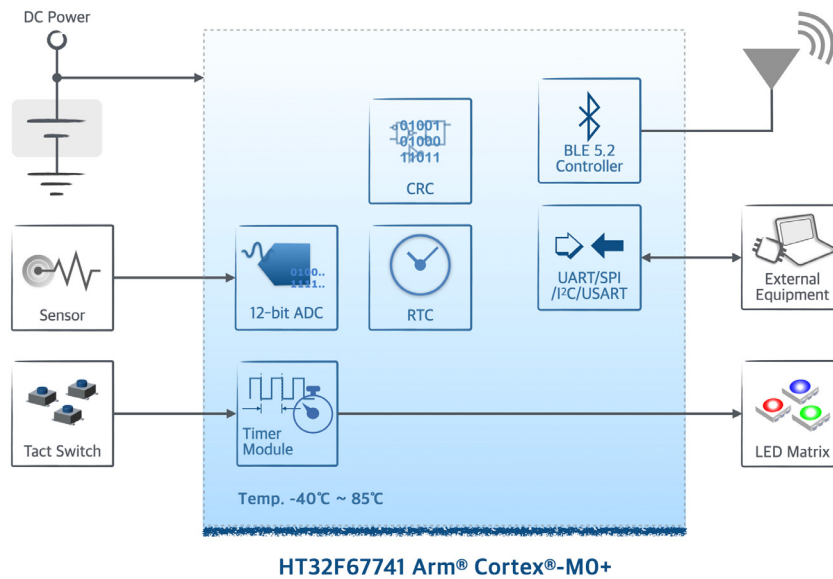

Arm® Cortex®-M0+ BLE Purpose Selection Guide

Cortex®-M0+ 32-Bit BLE MCU																	
Part No.	Max. Freq.	VDD	Flash	SRAM	ADC	Timer ¹	BQB	Data Rate	Output Power	Sensitivity	SCI ²	USB ³	LCD	Interface	Others	I/O	Package
HT32F67741	40MHz	2.0V~3.6V	64KB	8KB	1Msps 12-bit×6	BFTM×2, SCTM×4 GPTM×1, MCTM×1	5.2	1/2Mbps	+3.5dBm	-94/-91dBm	—	—	—	USART×1 UART×2 SPI×2, I²C×2	CRC TRNG	25 38	46QFN 64LQFP-EP
HT32F67742	60MHz	2.0V~3.6V	64KB	8KB	1Msps 12-bit×4	BFTM×2, PWM×3 GPTM×1	5.2	1/2Mbps	+3.5dBm	-94/-91dBm	√	√	29×4~25×8	USART×1 UART×2 SPI×2, I²C×2	CRC DIV TRNG	49	80LQFP-EP

Note: 1. BFTM: Basic Function Timer, SCTM: Single-Channel Timer, GPTM: General-Purpose Timer, MCTM: Motor Control Timer.
 2. SCI: ISO7816-3 Smart Card Interface.
 3. USB 2.0 Full Speed device.



Holtek Semiconductor Inc.

Sharing Success Through Excellence

Holtek Semiconductor Inc. (Headquarters)
 No.3, Creation Rd. II, Science Park, Hsinchu 300, Taiwan
 Tel: 886-3-5631999
 Fax: 886-3-5631189

Holtek Semiconductor (USA), Inc. (North America Sales Office)
 19 Hammond, Suite 513, Irvine, CA 92618
 Tel: 1-949-273-8988

Holtek Semiconductor Inc. (Taipei Sales Office)
 4F-2, No. 3-2, YuanQu St., Nankang Software Park,
 Taipei 115, Taiwan
 Tel: 886-2-2655-7070
 Fax: 886-2-2655-7373
 Fax: 886-2-2655-7383 (International sales hotline)

Holtek Semiconductor (China) Inc.
 Building No. 10, Xinzhu Court, (No. 1 Headquarters),
 4 Xinzhu Road, Songshan Lake, Dongguan, China 523808
 Tel: 86-769-3893-1999

Holtek Semiconductor (India) Pvt.Ltd.
 The Oriental Towers No. 461, 2nd Floor, 4th Sector,
 17th Cross Rd, HSR Layout, Bengaluru, Karnataka 560102
 Email: Indiasales@holtek.com.tw



Holtek Official Website



Best Modules
 Online Shop