

Product Specification

PART NUMBER # REV: FLD-101HMLG2PC001#01

DESCRIPTION: TFT 10.1" w, 1280(H)*800(V), LVDS, Full View, 1200CD + Rocktouch
PCAP USB / I2C with External DSA

Customer Name:	
Signature:	Date:

PREPARED BY	REVIEWED BY
<i>Jesse</i>	<i>David</i>

Revision History

Version	Date	Page	Description	Note
V1.0	2024/07/04		1st Edition	

FutureLabs Confidential

Table of Content

Product Specification	1
1. GENERAL DESCRIPTION	4
1.1 Description	4
1.2 Product Summary	4
2. ABSOLUTE MAXIMUM RATING	5
2.1 Electrical Absolute Rating	5
2.2 Environment Absolute Rating	5
3. Signal Electrical Characteristics	6
3.1 TFT LCD Module	6
3.2 Backlight Characteristics	6
3.3 DC and AC Characteristics	6
4. Signal Characteristic	7
4.1 Timing Chart	7
4.2 The Input Data Format	8
5. INTERFACE PIN DESCRIPTION	9
5.1 LCM Connector PIN Assignment	9
6. BLOCK DIAGRAM	11
7. OPTICAL CHARACTERISTIC	12
8. Touch Screen specification	15
8-1. Environmental Specification	15
8-2. Mechanical Specification	15
8-3. USB-I2C Combo Type Controller	15
9. OUTLINE DIMENSION	16
10. PRECAUTION AND PRODUCT HANDLING	17

FutureLabs Confidential

1. GENERAL DESCRIPTION

1.1 Description

10.1 inch is a Color Active Matrix Liquid Crystal Display Module composed of a Round TFT LCD panel and LED backlight system. The screen format is intended to support the 1280 x 800 screen and 16.7M colors.

1.2 Product Summary

The following items are summary on the table under Ta=25 °C condition:

No.	Item	Specification	Unit
1	Display Size	10.1"W	Inch
2	Display Format	1280(H) x (R,G,B) x 800(V)	Dots
3	Outline Dimension (H x V x D)	250.6 x 171.6 x 8.45 (Min.) 250.6 x 171.6 x 13.15 (Max.) PCB Zone	mm
4	Active Area	216.96 x 135.6	mm
5	Pixel Pitch	0.1695 x 0.1695	mm
6	Support Color	16.7 M	
7	Display Mode	Normally Black	--
8	Electrical Interface	LVDS	
10	Brightness	1200 (Typ)	cd/m2
11	Viewing Direction	All	--
12	Contrast Ratio	1000 (Typ.)	--
13	Input Voltage	3.3 (Typ.)	V
14	Response Time	25(Typ.)	W

2. ABSOLUTE MAXIMUM RATING

2.1 Electrical Absolute Rating

Item	Symbol	Values			Unit	Note
		Min	Typ	Max		
Power Supply Voltage	VDD	-0.3	-	3.9	V	GND=0

2.2 Environment Absolute Rating

Item	Symbol	Values			Unit	Note
		Min	Typ	Max.		
Operating Temperature	Top	-30	-	+80	°C	
Storage Temperature	Tstg	-30	-	+80	°C	

FutureLabs Confidential

3. Electrical Characteristics

3.1 TFT LCD Module

Item	Symbol	Values			Unit	Note
		Min	Typ	Max		
Power supply voltage	VDD	3.0	3.3	3.6	V	GND=0
Power Current	I _{VDD}	-	300	-	mA	
Input logic high voltage	V _{IH}	0.8VDD	-	3.6	V	
Input logic low voltage	V _{IL}	0	-	0.2VDD	V	

3.2 Backlight Characteristics

Parameter guideline for LED driving is under stable conditions at 25°C (Room Temperature):

Item	Symbol	Min.	Typ.	Max.	Unit	Remark
Power for Analog circuit	VDD_LED	11.0	12.0	13.0	V	GND=0
Backlight Current	I _{VDD_LED}	-	500	-	mA	
PWM Singal Voltage_High	VPWM	3.0	-	3.6	V	
PWM Singal Voltage_Low		0	-	0.4	V	
LED PWM Duty Cycle	T _D	1	-	100	%	
LED driver PWN Signal	LED_PWM	100	--	10K	HZ	GND=0
LED PWM High Threshold	V _{PWMH}	-	3.3	-	V	
LED PWM Low Threshold	V _{PWML}	-	0	-	V	
Operating LED life time	Hr	50000	-	-	Hours	(1)(2)

Note (1) LED life time (Hr) can be defined as the time in which it continues to operate under the condition:
 $T_a=25\pm 3^\circ\text{C}$, typical IL value indicated in the above table until the brightness becomes less than 50%.

Note (2) The “LED life time” is defined as the module brightness decrease to 50% original brightness at $T_a=25^\circ\text{C}$.
 The LED lifetime could be decreased if operating IL is larger. The constant current driving method is suggested.

3.3 DC and AC Characteristics

DC Electrical Characteristics

Item	Symbol	Min	Typ	Max	Unit	Note
Differential Input High Threshold Voltage	RXVTH	100	200	300	mV	
Differential Input Low Threshold Voltage	RXVTL	-300	-200	-100	mV	
Differential Input Common Mode Voltage	RXVCM	1.0	1.2	1.4	V	
Differential Input Voltage	IVIDI	200	-	600	mV	

4. Signal Characteristic

4.1 Timing Chart

Item	Symbol	Min.	Typ.	Max.	Unit
Frame Rate	Fr	-	60	-	Hz
Vertical Total Time	TV	824	838	872	TH
Vertical Display Time	TVD	800			TH
VSYNC back porch(with pulse width)	TVBP	23	23	23	TH
VSYNC front porch	TVFP	1	15	49	TH
Vertical Blanking Time	TVBP+TVFP	24	38	72	TH
Horizontal Total Time	TH	1380	1440	1500	Tclock
Horizontal Display Time	THD	1280			Tclock
HSYNC back porch(with pulse width)	THBP	88	88	88	Tclock
HSYNC front porch	THFP	12	72	132	Tclock
Horizontal Blanking Time	THBP+THFP	90	160	220	Tclock
Clock Rate	1/Tclock	66.3	72.4	78.9	MHz

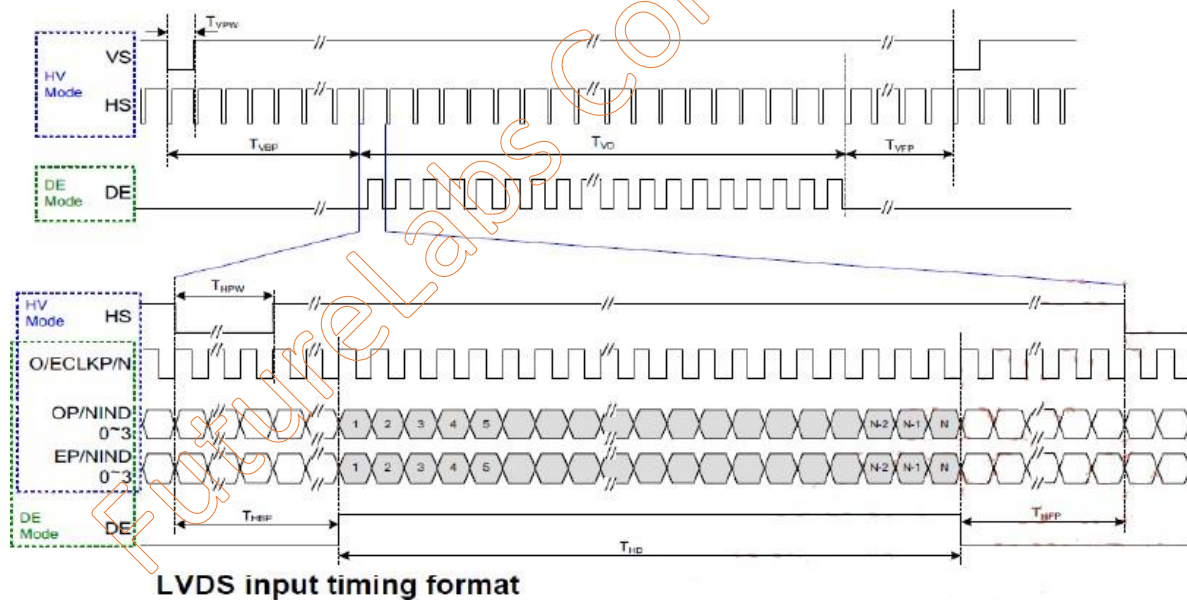

LVDS input timing format

4.2 The Input Data Format

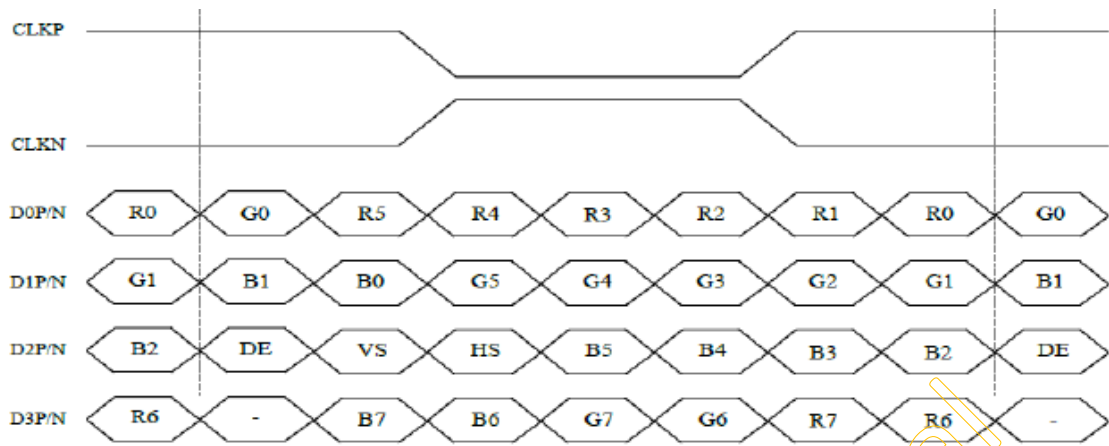

8bit LVDS input (VESA Format)

FutureLabs Confidential

5. INTERFACE PIN DESCRIPTION

5.1 LCM Connector PIN Assignment

A 40 Pin connector is used for the module electronics interface the recommended model is STM MSAK24025P40B or equivalent.

Pin No.	Symbol	I/O	Description
1	NC	-	No connection
2	VDD	P	power supply
3	VDD	P	power supply
4	NC	-	No Connection
5	NC	-	No Connection
6	NC	-	No Connection
7	NC	-	No connection
8	Rxin0N	I	-LVDS differential data
9	Rxin0P	I	+LVDS differential data
10	GND	P	Ground
11	Rxin1N	I	-LVDS differential data
12	Rxin1P	I	+LVDS differential data
13	GND	P	Ground
14	Rxin2N	I	-LVDS differential data
15	Rxin2P	I	+LVDS differential data
16	GND	P	Ground
17	RXCLKN	I	- LVDS differential clock input
18	RXCLKP	I	+ LVDS differential clock input
19	GND	P	Ground
20	Rxin3N	I	-LVDS differential data
21	Rxin3P	I	+LVDS differential data
22	GND	P	Ground
23	NC	-	No connection
24	NC	-	No connection
25	GND	P	Ground

26	NC	-	No connection
27	NC	-	No connection
28	GND	P	Ground
29	NC	-	No connection
30	NC	-	No connection
31	LED_K	P	Ground for LED Driver
32	LED_K	P	Ground for LED Driver
33	LED_K	P	Ground for LED Driver
34	NC	-	No connection
35	PWM	I	PWM signal for LED Driver Control Backlight Brightness
36	NC	-	No connection
37	NC	-	No connection
38	LED_A	P	Power Supply for LED Driver 12V
39	LED_A	P	Power Supply for LED Driver 12V
40	LED_A	P	Power Supply for LED Driver 12V

I : input O : output P : power

6. BLOCK DIAGRAM

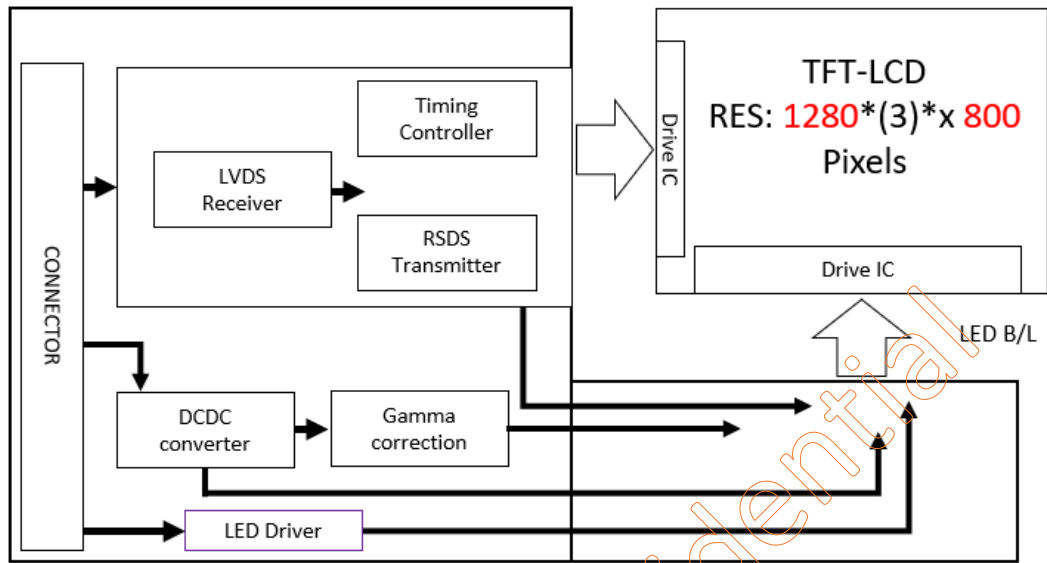

7. OPTICAL CHARACTERISTIC

The optical characteristics are measured under stable conditions at room temperature.

Item		Symbol	Condition	Min.	Typ.	Max.	Unit	Note	
Contrast Ratio		CR	$\theta_x=0^\circ$	800	1000	-	-	(2)(5)	
Response Time		TR	25°C	-	25	35	ms	(3)	
		TF							
Center Luminance of White		LC		1000	1200	-	cd/m ²	(4)(5)	
Brightness uniformity					75			%	(5)(6)
Chromaticity	Red	Rx		$\theta_x=0^\circ, \theta_y=0^\circ$ Viewing angle at normal direction	Typ. -0.03	0.618	Typ. +0.03	-	(1) (5)
		Ry	0.328			-			
	Green	Gx	0.335			-			
		Gy	0.542			-			
	Blue	Bx	0.136			-			
		By	0.145			-			
	White	Wx	0.322			-			
		Wy	0.342			-			
Viewing Angle	Horizontal	θ_{x+}	CR=10		80	85	-	Deg.	(1)(5)
		θ_{x-}			80	85	-		
	Vertical	θ_{y+}			80	85	-		
		θ_{y-}			80	85	-		

The following optical specifications shall be measured in a darkroom or equivalent state (ambient luminance <2 lux, and at room temperature).

The room temperature is 25°C±2°C.

Note 1: Definition of Viewing Angle

Viewing angle is the angle at which the contrast ratio is greater than 10. The viewing angles are determined for the horizontal or the vertical clock direction with respect to the optical axis which is normal to the LCD surface.

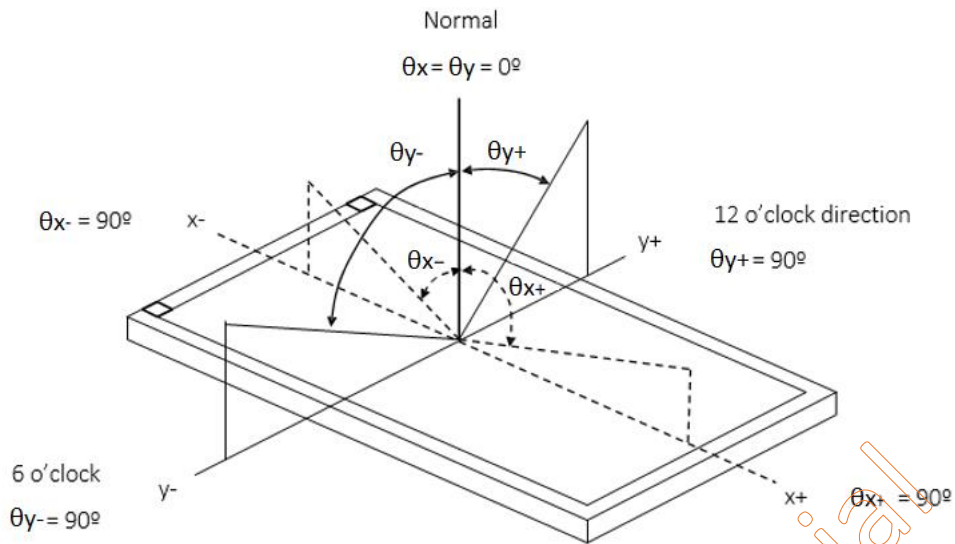

Note 2: Definition of Contrast Ratio (CR)

Measure the viewing angle of $\Theta = 0$ and at the center of the LCD surface. Luminance with all pixels in white state divide by Luminance with all pixels in Black state

Note 3: Definition of Response Time:

The response time is set initially by defining the "Rising Time (TR)" and the "Falling Time (TF)" respectively. Please refer the figure to the followings:

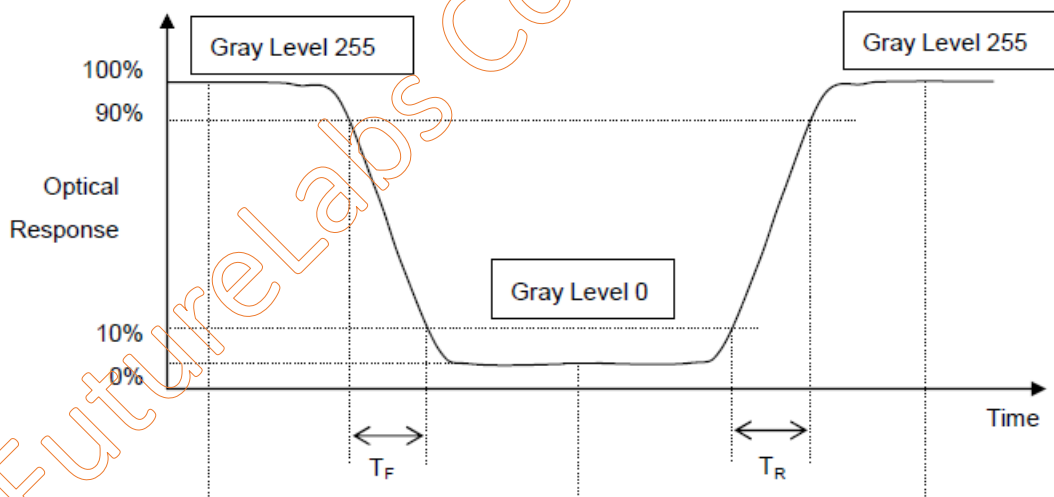

Note 4: Definition of Brightness (L)

Measure the center area of the panel and the viewing angle of the $\theta_x = \theta_y = 0^\circ$

Note 5: The method of optical measurement:

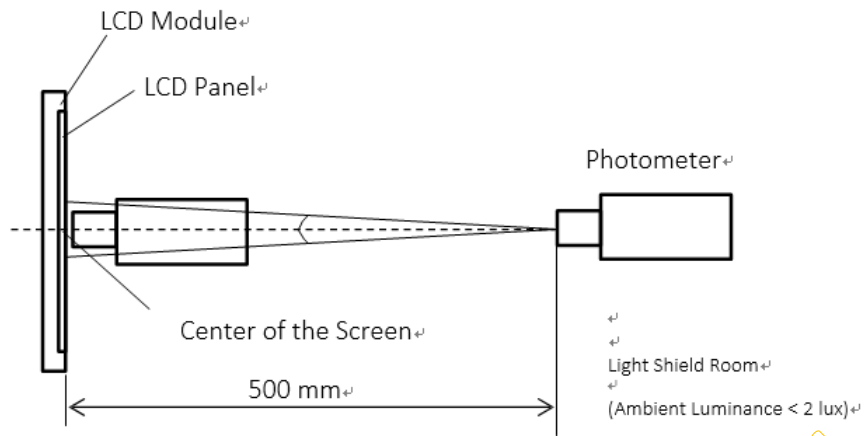

Note 6: Definition of White Variation (δW):

Measure the luminance of gray level 255 at 5 points

$$\delta W = (\text{Maximum } [L(1), L(2), L(3), L(4) \sim L(5)] / \text{Minimum } [L(1), L(2), L(3), L(4) \sim L(5)]) \times 100\%$$

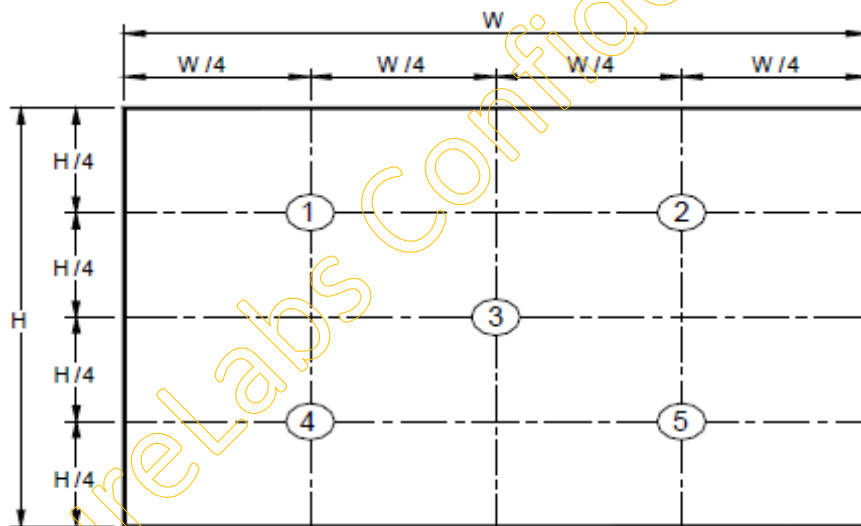

8. Touch Screen specification

8-1. Environmental Specification

Specification	Value
Operating Temperature	-30°C ~ 80°C
Storage Temperature	-30°C ~ 80°C
Operating Humidity	20% ~ 90%RH
Storage Humidity	10% ~ 90%RH

8-2. Mechanical Specification

Specification	Value
Operating Life (Finger input)	10 ⁷ times
Light Transmittance	>85% Min. (JIS K-7105) with glass
Surface hardness	6H
FPC Peeling Force	5N Max

8-3. USB-I2C Combo Type Controller

Parameters	Features
Circuit Board Dimension	Refer to drawings
Channels of Panel	Based on Sensor Design
Input Voltage	USB: 5VTyp. I2C: 5V/3.3V (3.2V Min.)
Linearity(Note 1)	Single Line drawing accuracy : Up to 1pt +/- 1mm offset /10mm
	Single Touch (point) accuracy : Up to 1pt +/- 1mm
Interface	USB: 2.0(Below) Full Speed I2C: 100K/400K Hz
Resolution	16384×16384 resolution
Power consumption(mA)	Active Mode: <108mA
	Idle Mode : <54mA
	Sleep Mode :<10mA
	(Operation Mode :Active Mode only)
Report rate(points/sec) Note(2)	> 100 Hz
Response time	Average < 25 ms

Note (1): Depending by Sensor design and other parameters, Refer to Windows 8 Logo regulation if need to follow min spec

Note (2): Report rate will vary by channel number, cover thickness, number of fingers and other parameter

9. OUTLINE DIMENSION

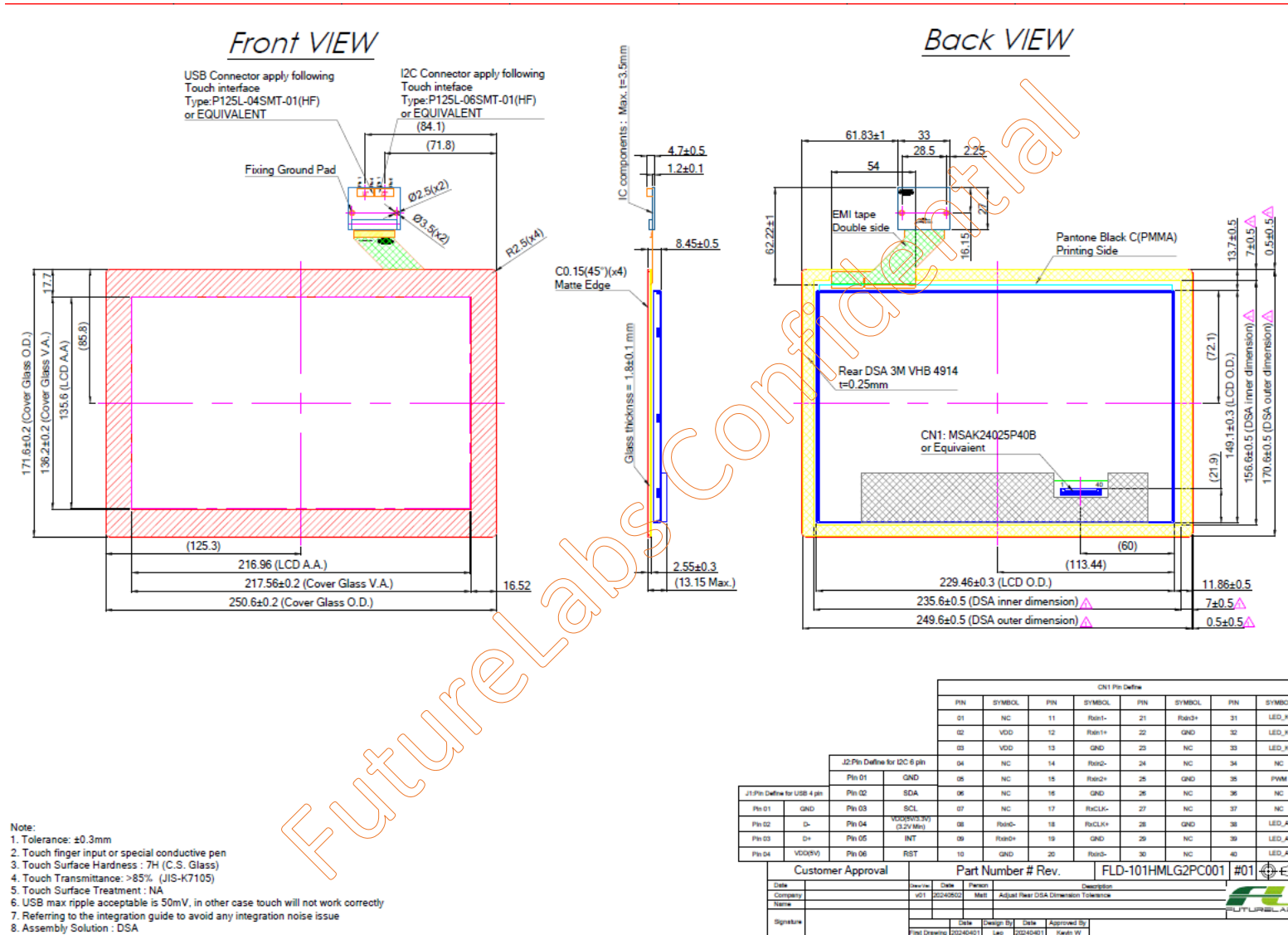

10. PRECAUTION AND PRODUCT HANDLING

- Do not apply the external force such as bending or twisting to the LCD panel and backlight during assembly.
- Do not insert and plug out the input connector while the LCD panel is operating.
- Do not take apart the panel or frame from LCD module assembly or insert anything into the backlight unit.
- Do not keep the same pattern in a long period of time, it may cause image sticking on LCD panel. Can use shuffle content periodically if fixed pattern is displayed on the screen.
- Do not touch the display area with bare hands, this will stain the display area.
- Pay attention to handle lead wire of backlight, that is not tugged in connect with LED driver.
- Do not change variable resistance settings in LCD panel, it may cause not satisfy of LCD characteristics specification.
- The surface of LCD panel's polarizer is very soft and easily scratched, please use a very soft dry cloth without chemicals for cleaning.
- To avoid the static electricity to damage the CMOS LSI, the operator should be grounded when in contact with the LCD panel, and also to all electrical equipment.
- Need to follow the correct power frequency when LCD panel is connecting and operating, this can avoid damage to CMOS LSI during latch-up.
- Need to store the LCD panel indoor without the exposure of sunlight where the temperature is $25^{\circ}\text{C} \pm 5^{\circ}\text{C}$ and the humidity is below 60% RH.