

PLCC Series

3528 0.5W PC Amber -Z

Datasheet - Automotive



Automotive Lighting



Outdoor Lighting



General Lighting



Indoor Lighting



Signal Lighting

Introduction :

Ultra high luminous efficacy, combined with the flexibility in design due to its slim and miniature size, PLCC LED Series are optimized to be used as lighting for automotive signal lighting designs or signboard.

Description :

- Best luminous and color uniformity
- Enables halogen and CDM replacement
- Automotive lighting interior and exterior.

Feature and Benefits :

- High luminous Intensity and high efficiency
- Based on Blue : InGaN technology
- Wide viewing angle : 120°
- Excellent performance and visibility
- Suitable for all SMT assembly methods
- IR reflow process compatible
- Environmental friendly; RoHS compliance
- Qualification according to AEC-Q101

Table of Contents

General Information	3
Absolute Maximum Ratings	4
Characteristic	4
Luminous Flux Characteristics	5
Voltage Bin Structure	5
Mechanical Dimensions	6
PC Amber Bin Coordinates.....	7
Characteristic curve.....	8
Reliability.....	13
Product Packaging Information.....	14
Revision History	15
About Edison Opto	15

General Information

Ordering Code Format

2 T 03 X5 AX B 00 03 XXX
 X1 X2 X3-X4 X5-X6 X7-X8 X9 X10-X11 X12-X13 X14-X16

X1	X2		X3-X4		X5-X6		X7-X8	
Type	Component		Series		Wattage		Color/CCT	
2	Emitter	T	PLCC	03	3528	X5	0.5W	AX Amber

X9	X10-X11		X12-X13		X14-X16	
BIN	CRI		Voltage		Serial Number	
B	PC Amber	00	-	03	3V	-

Absolute Maximum Ratings

Parameter	Symbol	Rating	Units
Forward Current	I_F	20...200	mA
Pulse Forward Current (tp<=100μs, Duty cycle=0.25)	-	300	mA
Reverse Voltage	V_R	-	V
Reverse Current	I_R	10	uA
LED Junction Temperature	T_J	125	°C
ESD Sensitivity	V_B	2000	V
Operating Temperature	-	-40 ~ +100	°C
Storage Temperature	-	-40 ~ +125	°C
Soldering Temperature	-	255~260	°C
Manual Soldering at 350°C (Max.)	-	3	Sec

Notes:

1. Proper current derating must be observed to maintain junction temperature below the maximum at all time.
2. LEDs are not designed to be driven in reverse bias.
3. tp: Pulse width time

Characteristic

Optical Characteristics at $T_J=25^{\circ}\text{C}$

Parameter	Symbol	Value	Units
Viewing Angle	$2\theta_{1/2}$	120	Degree
Thermal resistance	(Rth J-A)	90	°C/W
	(Rth J-S)	40	
Wavelength	-	585-595	nm
JEDEC Moisture Sensitivity	-	Level 2a Floor Life Conditions: ≤30°C / 60% RH Soak Requirements(Standard) Time (hours): 120+1/-0 Conditions: 60°C / 60% RH	-

Notes:

1. Wavelengths are stated as dominant wavelength.
2. Edison Opto maintains a tolerance of ± 1nm for dominant wavelength.

Luminous Flux Characteristics

Luminous Flux characteristics @ $I_f=150\text{mA}$, @ $T_j=25^\circ\text{C}$

Color	Group	Min. Luminous Flux (lm)	Max. Luminous Flux (lm)	Forward Current (mA)	Order Code
Amber	Q2	34.8	39.4	150	2T03X5AXB00030A1
	R1	39.4	45.3		
	R2	45.3	51.2		
	S1	51.2	58.8		

Note:

Luminous flux is measured with an accuracy of $\pm 10\%$

Voltage Bin Structure

Group	Min. Voltage (V)	Max. Voltage (V)
VB1	2.9	3.0
VC1	3.0	3.1
VA2	3.1	3.2
VB2	3.2	3.3
VC2	3.3	3.4

Note:

Forward voltage measurement allowance is $\pm 0.06\text{V}$.

Mechanical Dimensions

Emitter Type Dimension

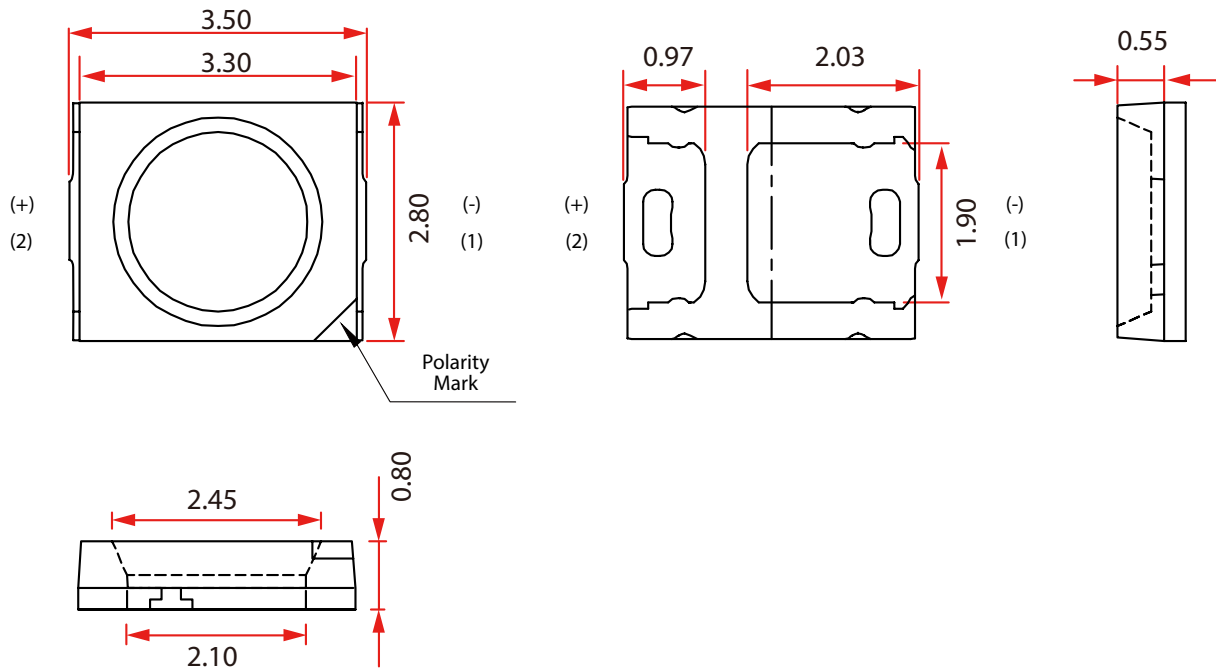

Circuit

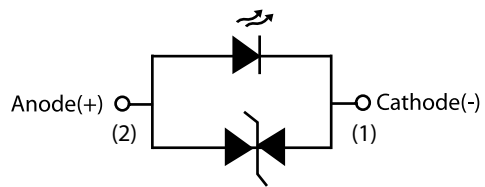

Solder Pad

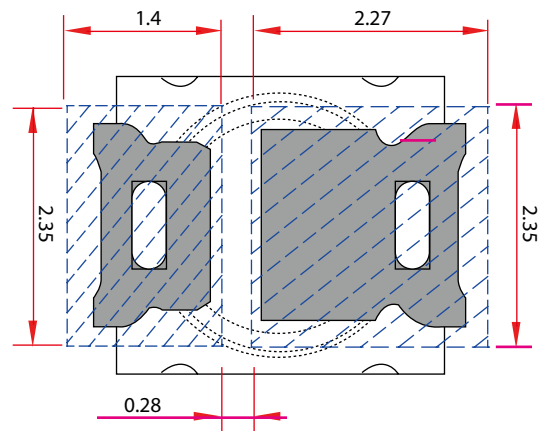

Notes:

1. All dimensions are measured in mm.
2. Tolerance : ± 0.2 mm

PC Amber Bin Coordinates

PC Amber CIE

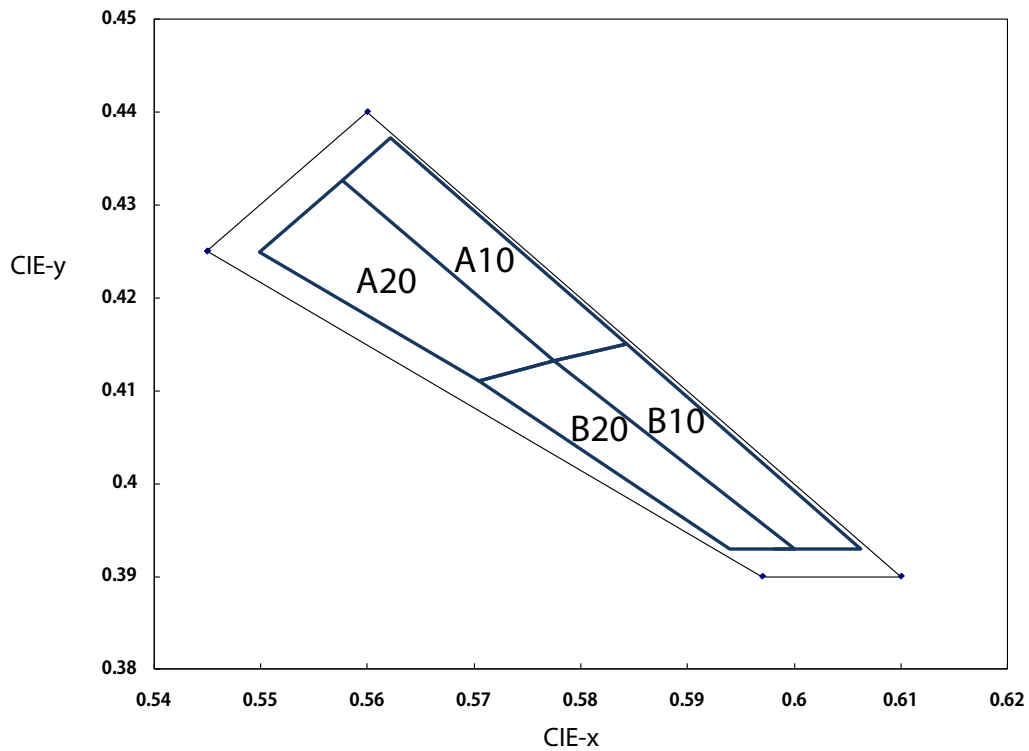

Color Bin	X	Y	Color Bin	X	Y
A10	0.5775	0.4132	A20	0.5705	0.4111
	0.5843	0.4151		0.5775	0.4132
	0.5622	0.4372		0.5576	0.4326
	0.5576	0.4326		0.5499	0.4249
B10	0.5775	0.4132	B20	0.5705	0.4111
	0.5843	0.4151		0.5775	0.4132
	0.6062	0.3930		0.6000	0.3930
	0.5982	0.3930		0.5940	0.3930

Notes:

1. PLCC 3528 PC Amber Emitters are tested and binned by x,y coordinates.
2. Edison maintains a tester tolerance of ± 0.005 on x, y color coordinates.
3. Test conditions of 150mA with current pulse duration of 20ms.

Characteristic curve

Color Spectrum

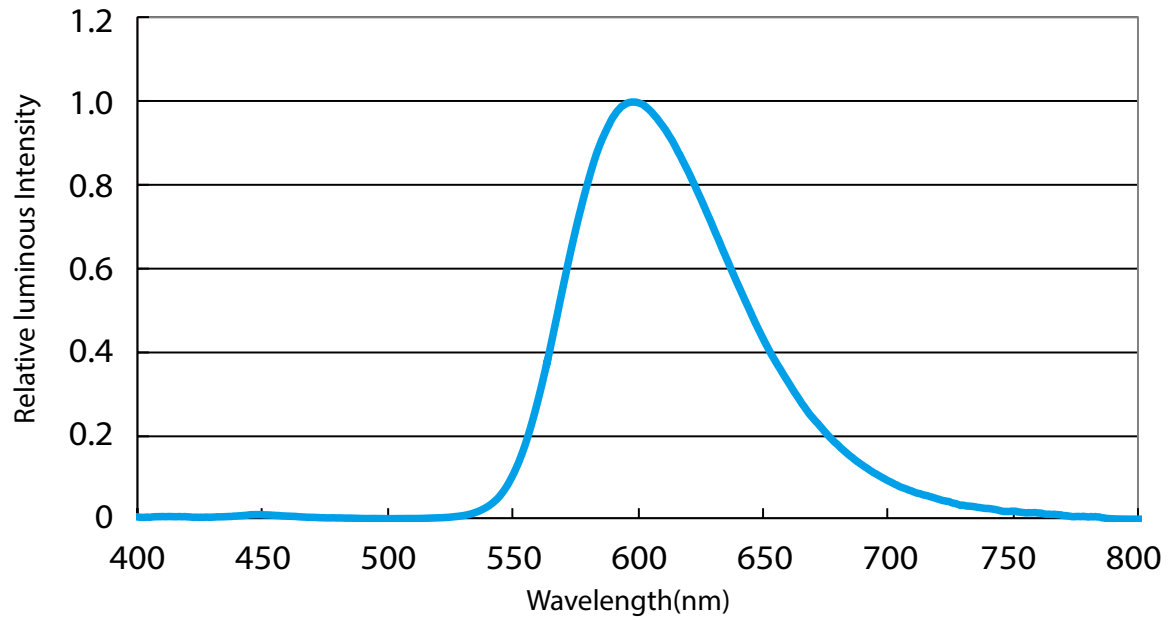

Beam Pattern

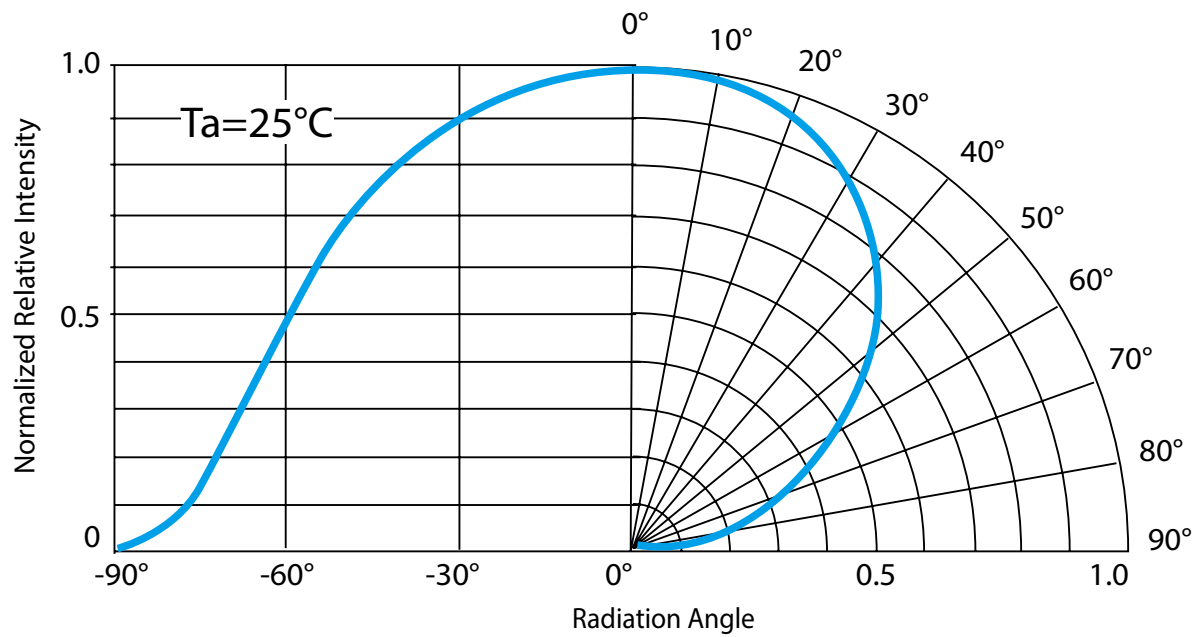

Forward Current vs. Forward Voltage

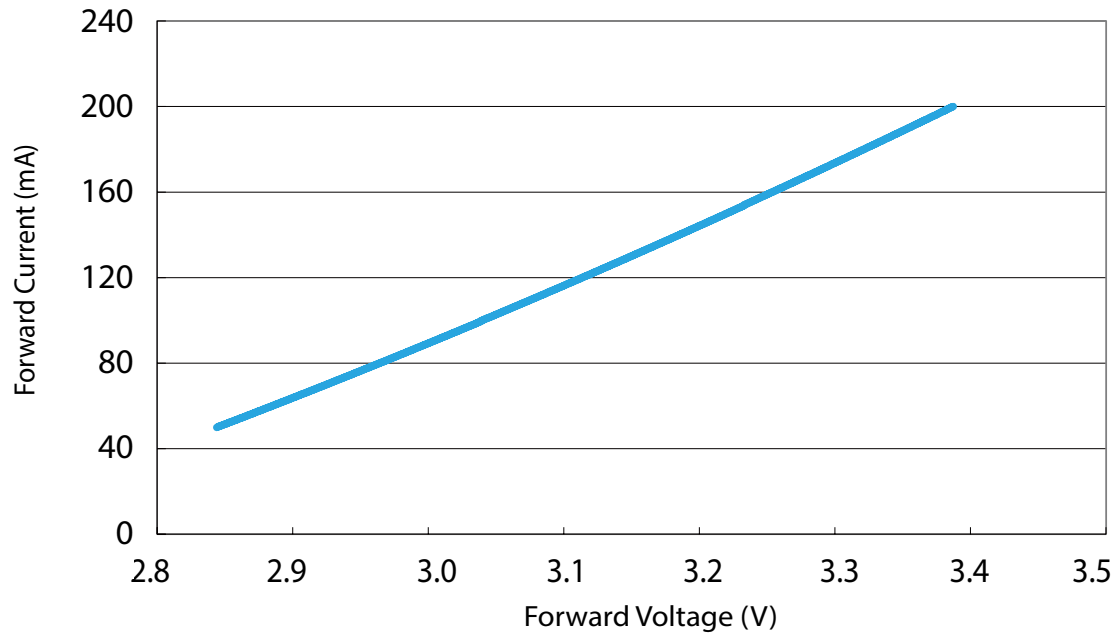

Relative Luminous Intensity vs. Forward Current

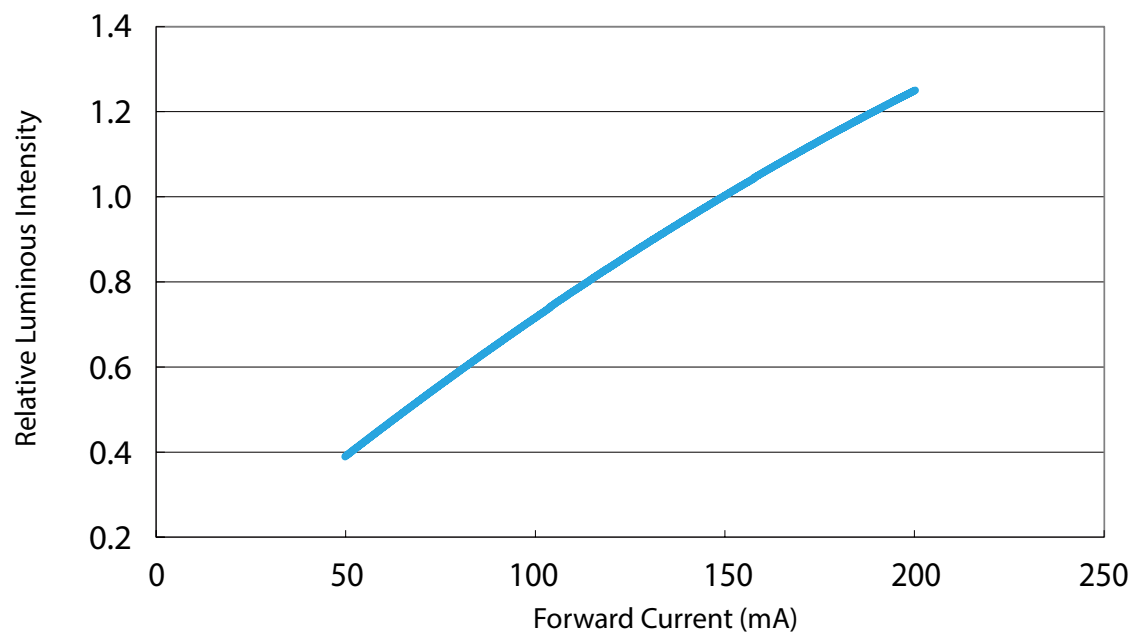

Relative Luminous Flux vs. Junction Temperature

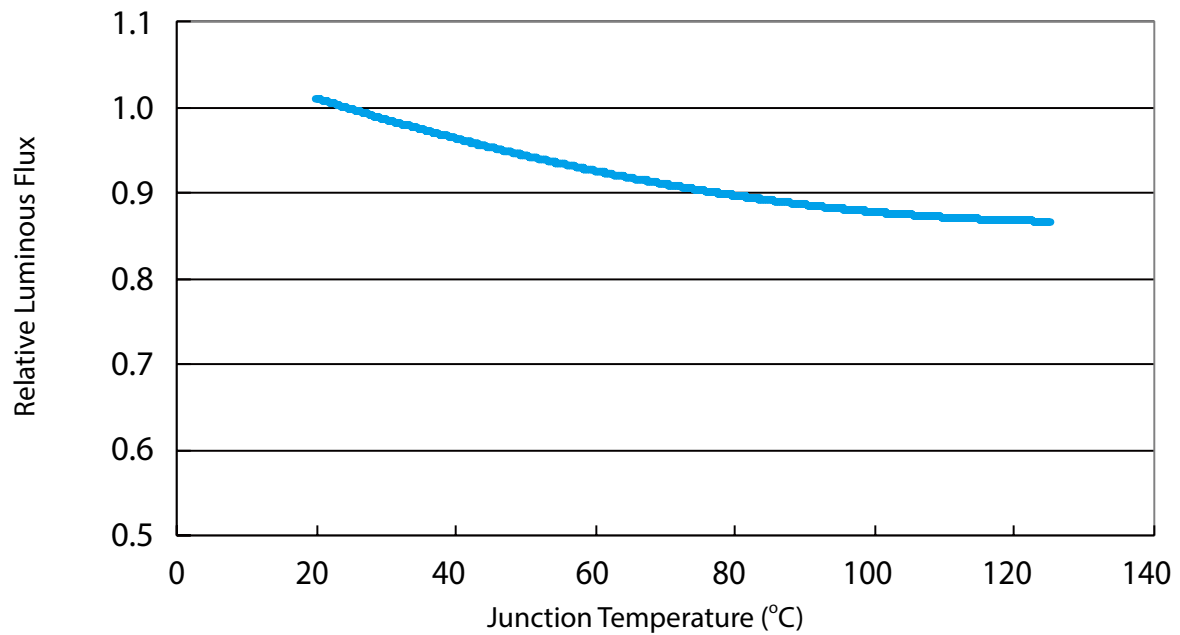

Forward Voltage vs. Junction Temperature

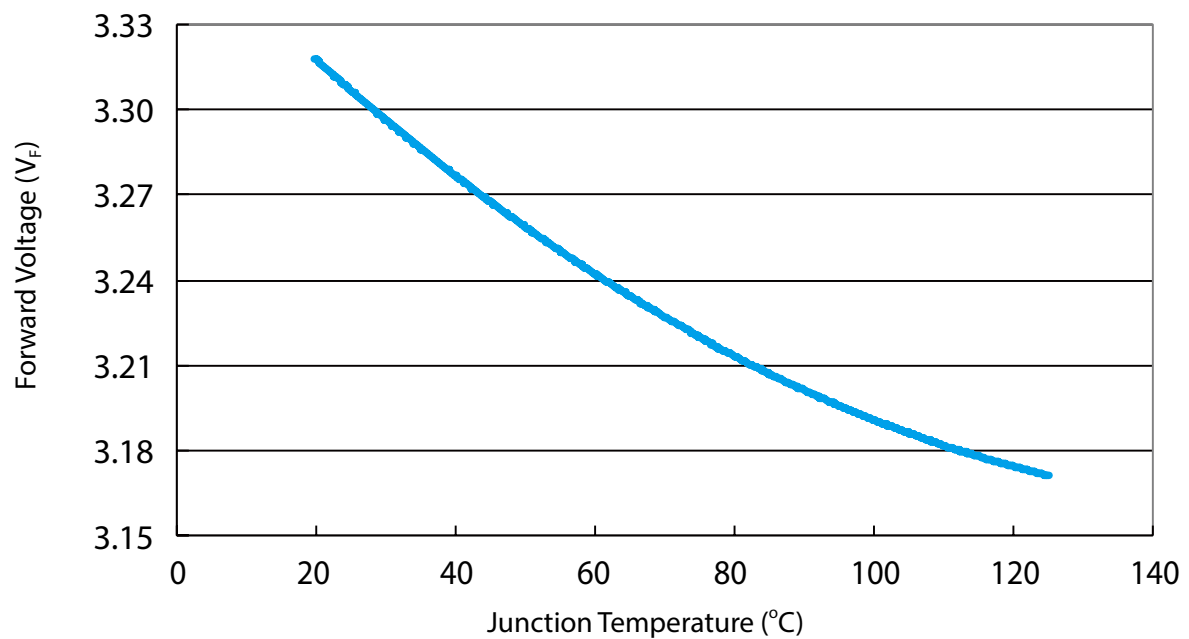

$\Delta x, \Delta y$ vs. Forward Current

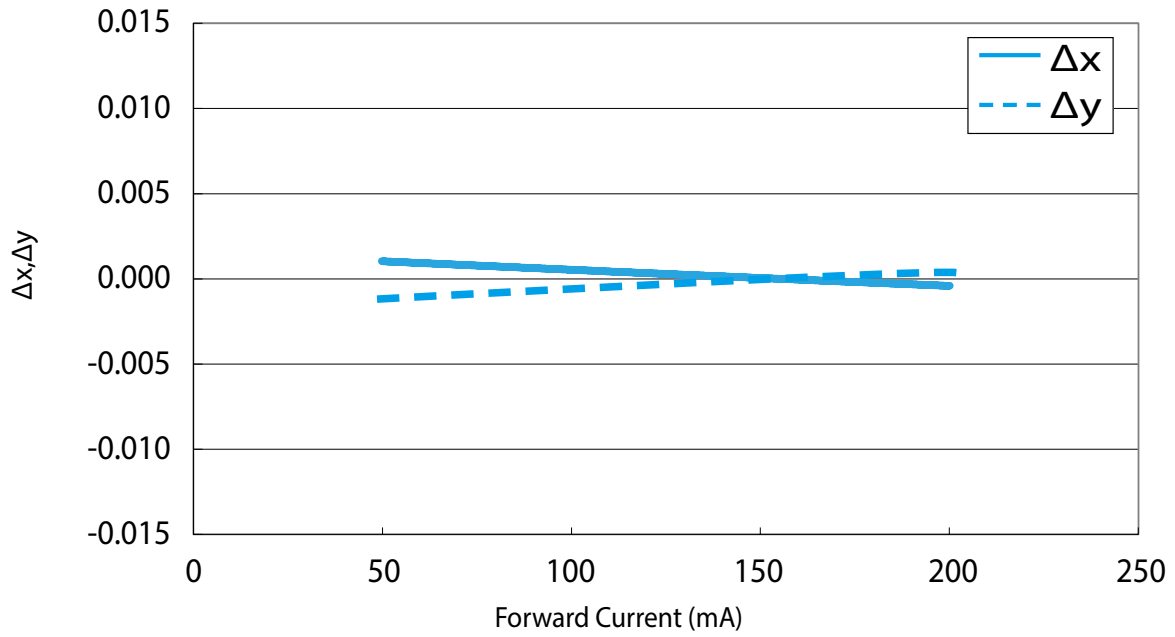

$\Delta x, \Delta y$ vs. Junction Temperature

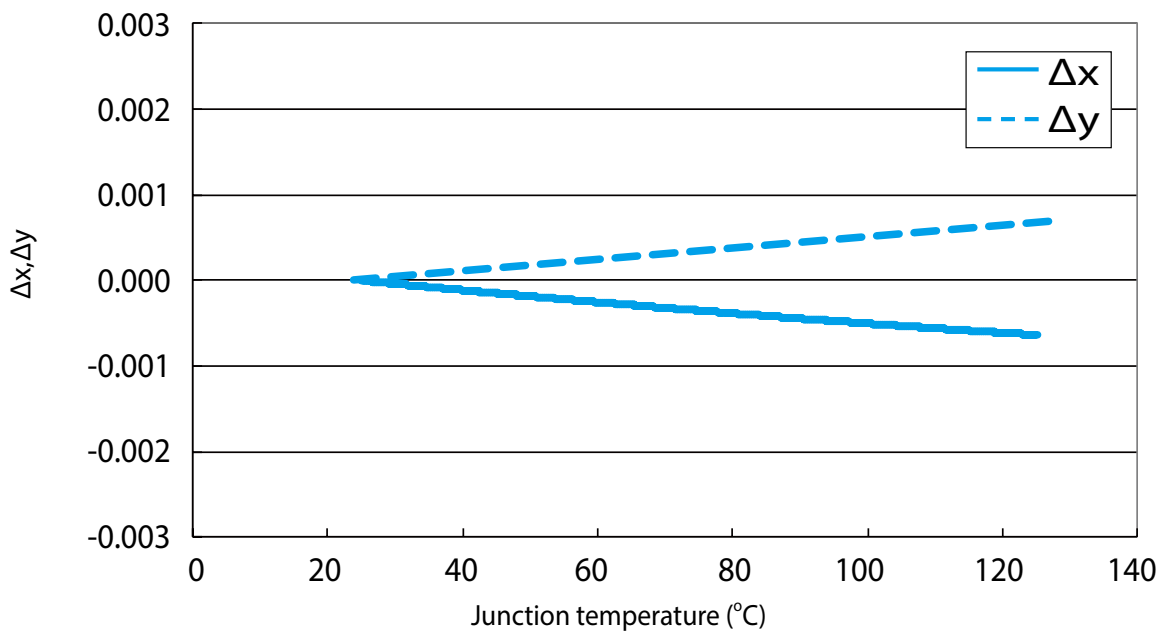

Maximum Current vs. Temperature

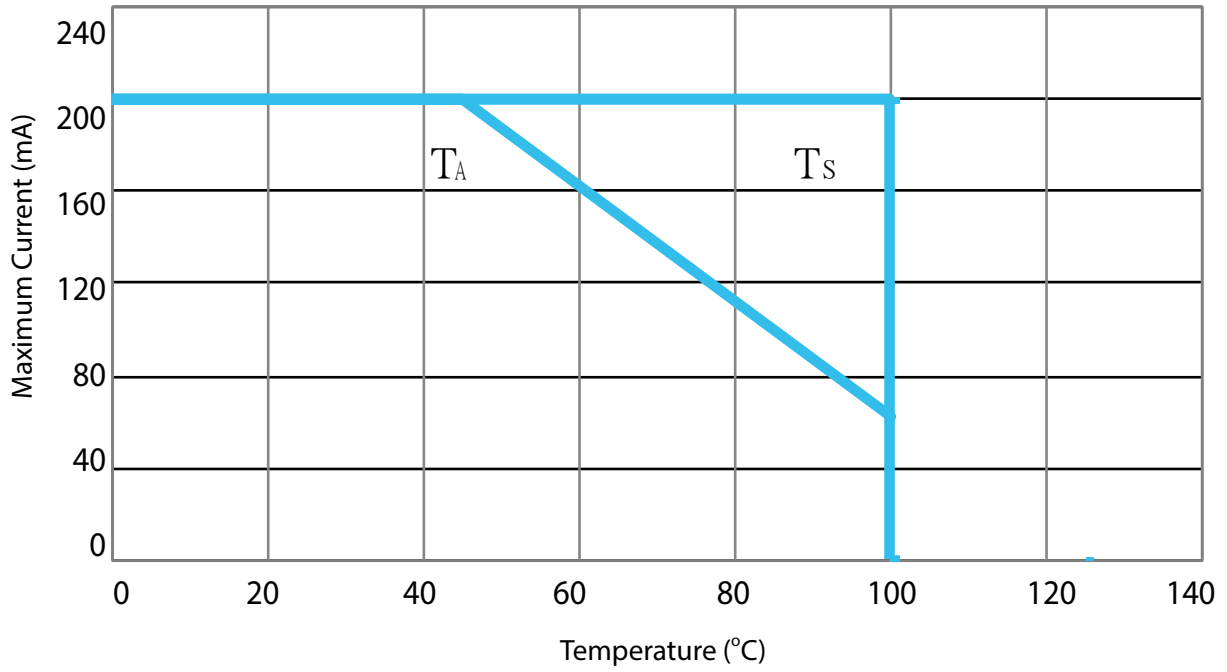

Reliability

NO.	Test Item	Reference	Test Condition	Duration/ Cycle	Failure Criteria	Sample size
1	External Visual	JESD22 B-101	Visual Inspection	---	No visual damage	77
2	Physical Dimension	JESD22 B-100	Verify physical dimensions against device mechanical drawing	1 times	CPK>1.33	30
3	High Temperature Forward Bias	JESD22 A-108	Ta=100°C, IF=200mA	1,000 hrs	1. VF+/- 10% 2. Iv+/- 15% 3. Cx/Cy+/- 0.02	77
4	Temperature Cycle	JESD22 A-104	Ta=-40°C~100°C, 30min dwell, 5 min transfer	1000 Cycle	No dead lamps and visual damage	77
5	Thermal Shock	JESD22 A-104	-40°C/125°C, 20min dwell, <10sec transfer	1000 Cycle	No dead lamps and visual damage	77
6	High Temperature High Humidity Bias	JESD22 A-101	Ta=85°C RH=85%, IF=200mA	1,000 hrs	1. VF+/- 10% 2. Iv+/- 15% 3. Cx/Cy+/- 0.02	77
7	Intermittent Operational Life	MIL-750 1037	Ta=25°C, 3sec on, 3sec off, IF=200mA	10W times	No dead lamps and visual damage	77
8	Power and Temperature Cycle	JESD22 A-105	Ta=-40°C~100°C, 30min dwell, 5min transfer, IF=200mA	1,000 hrs	1. VF+/- 10% 2. Iv+/- 15% 3. Cx/Cy+/- 0.02	77
9	D.P.A.	AEC-Q101-004 Section 4	Random Sample TC	---	No visual damage	2
10	Resistance to Soldering Heat	MIL-202 Method 210	Solder iron temperature : 350 °C ± 10 °C. dwell time : 4~5 seconds	4~5 seconds	Desoldering performance	30
11	Solderability	J-STD-002	Ta=245°C±5°C, 3sec	5 seconds	Over 95% area	10
12	High Temperature storage	Jesd22A-103B	Ta=100°C	1,000 hrs	No dead lamps and visual damage	77
13	Low Temperature storage	Jesd22A-119	Ta=-40°C	1,000 hrs	No dead lamps and visual damage	77

Cautions

LEDs should be stored or lighted in the environment of no sulfur.

Some materials, such as plastic seals, printing ink, enclosures and adhesives, may contain sulfur.

LEDs also should not be exposed in the acid or halogen environment.

Product Packaging Information

3528 Dimension

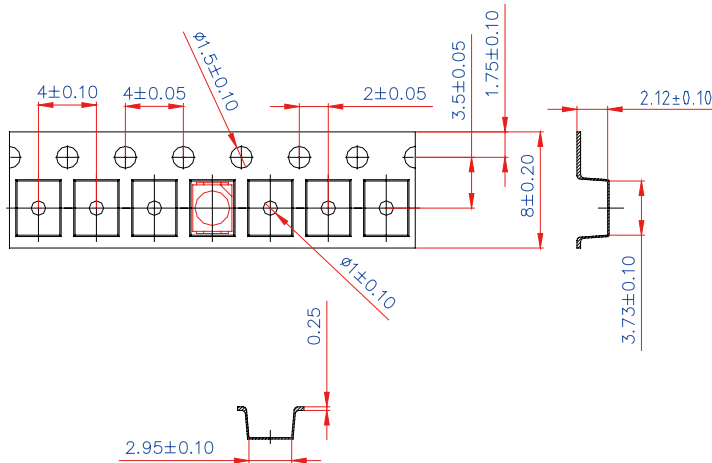

Taping Reel

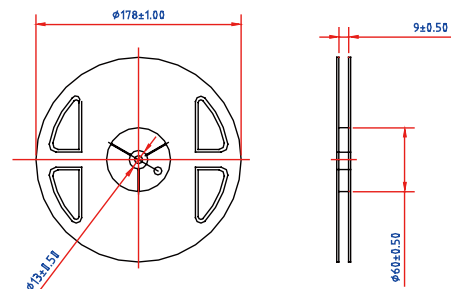

Quantity and Package Dimension

There is package quantity for PLCC LEDs. Please confirm the noted quantity before unseal.

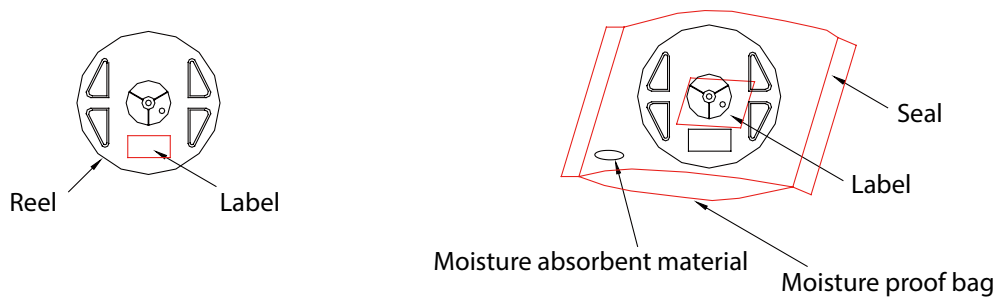

Item	Quantity	Total	Dimensions (mm)
Reel	4,000pcs	4,000pcs	R=178
Starting with 150pcs empty, and 150pcs empty at the last			

Revision History

Versions	Description	Release Date
1	Establish a Datasheet	2016/7/26
2	1. Revise Mechanical dimensions 2. Update the value of thermal resistance	2016/11/11
3	Update Reliability	2017/5/12
4	1.Update Reliability 2.Update Maximum Current vs Ambient Temperature	2018/6/5
5	Modify the Reliability Modify file title	2018/9/5

About Edison Opto

Edison Opto is a leading manufacturer of high power LED and a solution provider experienced in LDMS. LDMS is an integrated program derived from the four essential technologies in LED lighting applications- Thermal Management, Electrical Scheme, Mechanical Refinement, Optical Optimization, to provide customer with various LED components and modules. More Information about the company and our products can be found at www.edison-opto.com

Copyright©2018 Edison Opto. All rights reserved. No part of publication may be reproduced or transmitted in any form or by any means, electronic or mechanical, including photo copy, recording or any other information storage and retrieval system, without prior permission in writing from the publisher. The information in this publication are subject to change without notice.

www.edison-opto.com

For general assistance please contact:
service@edison-opto.com.tw

For technical assistance please contact:
LED.Detective@edison-opto.com.tw