

Edixeon® Federal Series Datasheet

Edixeon® Federal is a surface mount, compact, high brightness LED that is built for various illumination needs. A single Cool White Edixeon® Federal can deliver typical luminous flux of 90 lm while driving at 350mA suitable for any kind of lighting sources, including general illumination, flashlights, streetlights, spotlights, signal lights, industrial and commercial lightings. The small physical dimension can free customers from any constraints or limitations in these fields of applications. Furthermore, the reflow-solderable nature of Edixeon® Federal provides an easy path towards the optimum thermal management to achieve a promising reliability. In conclusion, Edixeon® Federal offers you an extraordinary LED experience.

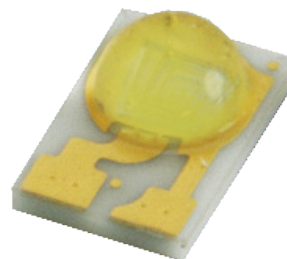

Features :

- High lumen performance
- Promising lumen maintenance characteristics
- High efficiency package
- Level 1 on JEDEC moisture sensitivity analysis
- 350mA – 700mA drive current
- RoHS compliant

Typical Applications

- | | | |
|-----------------------------|-----------------------|--------------------------|
| ■ Reading lights | ■ Decoration lights | ■ Contour lights |
| ■ Up-lights and Down-lights | ■ Beacon lights | ■ Garden lighting |
| ■ General lighting | ■ Portable flashlight | ■ Architectural lighting |
| ■ Ceiling lights | ■ LCD Backlights | |



Lighting Design Manufacturing Service

Table of Contents

• Product Nomenclature.....	3
• Environmental Compliance.....	4
• LED Package Dimension and Polarity.....	4
• Absolute Maximum Ratings.....	5
• Luminous Flux Characteristics.....	6
• Forward Voltage Characteristics.....	8
• JEDEC Moisture Sensitivity.....	9
• Reliability Items and Failure Measures.....	10
• Color Spectrum and Radiation Pattern.....	11
• Optical and Electrical Curves.....	11
• Reflow Profile.....	14
• Product Packing Information.....	15
• Bin Groups.....	16



Lighting Design Manufacturing Service

Product Nomenclature

The following table describes the available color, power, and lens type. For more flux and forward voltage information, please consult the Bin Group document.

E F EW - 1 A E 1

X1 X2 X3 X4 X5 X6 X7

X1 LED Item		X2 Module		X3 Emitting Color		X4 Power		X5 Lens Item	
Code	Type	Code	Type	Code	Type	Code	Type	Code	Type
EF	Edixeon®Federal	E	Emitter	W	Cool White	1	350mA	A	4.5mmx3mm
		S	Star	H	Neutral White	3	700mA		
				X	Warm White				
				R	Red				
				A	Amber(615nm)				
				T	True Green				
				B	Blue				
				D	Dental Blue				
				C	Royal Blue				
				E	Deep Red				
				F	Cherry Red				
				I	IR 850nm				
				J	Cyan				
				N	IR 940nm				
				V	Ultraviolet				

X6 Housing Item		X7 Serial No.	
Code	Type		
E	E-type		

Figure 1. Edixeon® Federal Nomenclature

Environmental Compliance

Edixeon® Federal is compliant to the Restriction of Hazardous Substances Directive or RoHS. The restricted materials including lead, mercury cadmium hexavalent chromium, polybrominated biphenyls (PBB) and polybrominated diphenyl ether (PBDE) are not used in Edixeon® Federal to provide an environmentally friendly product to the customers.

LED Package Dimension and Polarity

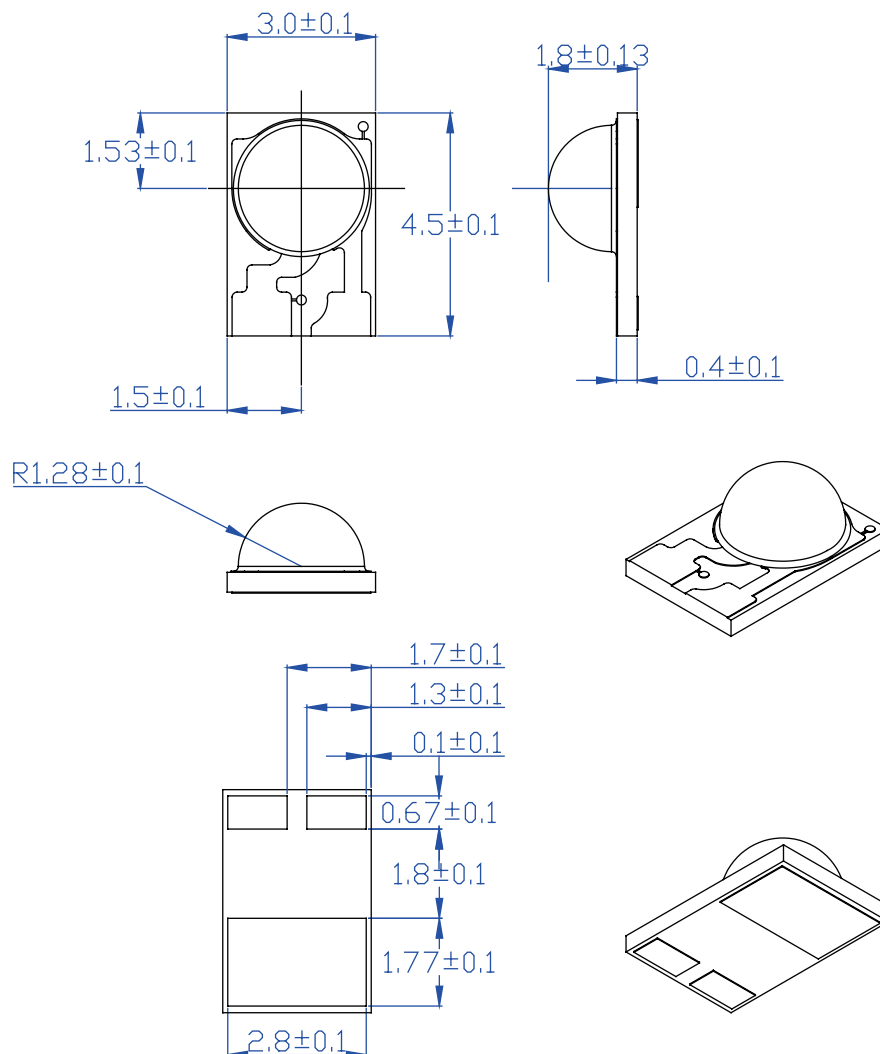

Figure 2. Edixeon® Federal series Dimension

Notes:

1. All dimensions are measured in mm.
2. Drawings are not to scale.

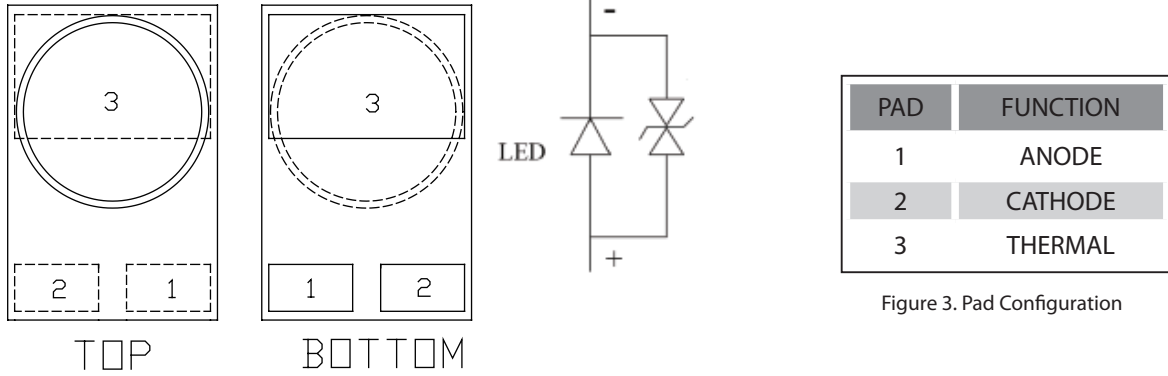

Figure 3. Pad Configuration

Notes:
The thermal pad is electrically isolated from anode and cathode.

Absolute Maximum Ratings

The following tables describe flux of Edixeon® Federal series under various current and different color.

Table 1 . Edixeon® Federal series absolute maximum ratings

Parameter	Symbol	Rating	Units
DC Forward Current ^[1]	I_F	350 / 700	mA
Peak Pulsed Current; ($t_p \leq 100\mu s$, Duty cycle=0.25)	I_{pulse}	1000	mA
Transient Surge Voltage		8	V
Reverse Voltage ^[2]	V_R	Note 2	V
LED Junction Temperature ^[3]	T_J	150 / 125 ^[4]	°C
Operating Temperature		-40 ~ +80	°C
Storage Temperature		-40 ~ +120	°C
ESD Sensitivity		8,000	V
Allowable Reflow Cycles		3	cycles
Soldering Temperature		260	°C

Notes:
1. Maximum forward current for 1W and 3W are 350mA and 700mA respectively.
2. LEDs are not designed to drive in reverse bias.
3. Proper current derating must be observed to maintain junction temperature below the maximum.
4. The maximum junction temperature for Red, Amber, Deep Red and Cherry Red is 125°C.

Luminous Flux Characteristics

The following tables describe flux of Edixeon® Federal series under various current and different color.

Table 2 . Luminous flux characteristics at $I_f=350\text{mA}$ and $\text{Pad}=25^\circ\text{C}$

Power Consumption	Part Name	Color	Flux			Units
			Min.	Typ.	Max.	
1W	EFEW-1AE1	Cool White	--	90	--	lm
	EFEH-1AE1	Neutral White	--	80	--	lm
	EFEY-1AE1	Warm White	--	65	--	lm
	EFER-1AE1	Red	--	50	--	lm
	EFEA-1AE1	Amber	--	45	--	lm
	EFET-1AE1	True Green	--	70	--	lm
	EFEB-1AE1	Blue	--	20	--	lm
	EFED-1AE1	Dental Blue	--	300	--	mW
	EFEC-1AE1	Royal Blue	--	400	--	mW
	EFEJ-1AE1	Cyan	--	40	--	lm
	EFEI-1AE1	Deep Red	--	150	--	mW
	EFEF-1AE1	Cherry Red	--	115	--	mW
	EFEV-1AE1	Ultraviolet	--	230	--	mW
	EFEI-1AE1	IR 850nm	--	275	--	mW
	EFEN-1AE1	IR 940nm	--	170	--	mW

Table 3 . Luminous flux characteristics at $I_f=700\text{mA}$ and $\text{Pad}=25^\circ\text{C}$

Power Consumption	Part Name	Color	Flux			Units
			Min.	Typ.	Max.	
3W	EFEW-3AE1	Cool White	--	160	--	lm
	EFEH-3AE1	Neutral White	--	130	--	lm
	EFEY-3AE1	Warm White	--	120	--	lm
	EFER-3AE1	Red	--	85	--	lm
	EFET-3AE1	True Green	--	130	--	lm
	EFEB-3AE1	Blue	--	30	--	lm
	EFEA-3AE1	Amber	--	80	--	lm

Note:

The luminous flux performance is guaranteed within published operating conditions. Edison maintains a tolerance of $\pm 10\%$ on flux measurements.

• Color Temperature or Dominant/Peak Wavelength Characteristics

Table 4 . Color Temperature/ Peak Wavelength characteristics at $I_f=350\text{mA}$ and $T_j=25^\circ\text{C}$

Power Consumption	Part Name	Color	Flux			Units
			Min.	Typ.	Max.	
1W	EFEW-1AE1	Cool White	5,000	--	10,000	K
	EFEH-1AE1	Neutral White	3,800	--	50,00	K
	EFEK-1AE1	Warm White	2,670	--	3,800	K
	EFER-1AE1	Red	620	--	630	nm
	EFEA-1AE1	Amber	585	--	595	nm
	EFET-1AE1	True Green	515	--	535	nm
	EFEB-1AE1	Blue	455	--	475	nm
	EFED-1AE1	Dental Blue ^[1]	450	--	470	nm
	EFEC-1AE1	Royal Blue ^[1]	440	--	460	nm
	EFEJ-1AE1	Cyan	490	--	510	nm
	EFEI-1AE1	Deep Red ^[1]	650	--	670	nm
	EFEF-1AE1	Cherry Red ^[1]	730	--	750	nm
	EFEV-1AE1	Ultraviolet ^[1]	390	--	410	nm
	EFEI-1AE1	IR 850nm ^[1]	840	--	860	nm
	EFEV-1AE1	IR 940nm ^[1]	930	--	950	nm

Notes:

1. Wavelengths are stated as peak wavelength.

2. Edison maintains a tolerance of $\pm 0.5\text{nm}$ for dominant wavelength, $\pm 2\text{nm}$ for peak wavelength and $\pm 5\%$ on CCT measurement.

Forward Voltage Characteristics

Table 5 . Forward Voltage characteristics at $T_j=25^{\circ}\text{C}$

Power Consumption	Part Name	Color	Forward Current (mA)	Flux			Units
				Min.	Typ.	Max.	
1W	EFEW-1AE1	White	350	3.0	--	4.0	V
	EFEH-1AE1	Neutral White	350	3.0	--	4.0	
	EFEY-1AE1	Warm White	350	3.0	--	4.0	
	EFER-1AE1	Red	350	2.0	--	3.0	
	EFEA-1AE1	Amber	350	2.0	--	3.0	
	EFET-1AE1	True Green	350	2.8	--	4.0	
	EFEB-1AE1	Blue	350	3.0	--	4.0	
	EFED-1AE1	Dental Blue	350	3.0	--	4.0	
	EFEC-1AE1	Royal Blue	350	3.0	--	4.0	
	EFEJ-1AE1	Cyan	350	2.8	--	4.0	
	EFEI-1AE1	Deep Red	350	2.0	--	3.0	
	EFEF-1AE1	Cherry Red	350	2.0	--	3.0	
	EFEV-1AE1	Ultraviolet	350	3.0	--	4.0	
	EFEI-1AE1	IR 850nm	700	1.5	--	2.5	
	EFEN-1AE1	IR 940nm	700	1.5	--	2.5	
3W	EFEW-3AE1	White	700	3.0	--	4.0	V
	EFEH-3AE1	Neutral White	700	3.0	--	4.0	
	EFEY-3AE1	Warm White	700	3.0	--	4.0	
	EFER-3AE1	Red	700	2.0	--	3.0	
	EFET-3AE1	True Green	700	2.8	--	4.0	
	EFEB-3AE1	Blue	700	3.0	--	4.0	
	EFEA-3AE1	Amber	700	2.0	--	3.0	

Note:
Edison maintains a tolerance of 0.06V on forward voltage measurement.



Lighting Design Manufacturing Service

• Emission Angle Characteristics

Table 6 . Emission Angle characteristics

2 θ ^{1/2} (Typ.) Lambertian	Units
120	Degrees

• JEDEC Moisture Sensitivity

Table 7 . JEDEC Moisture Sensitivity

Level	Floor Life		Soak Requirements	
	Time	Conditions	Standard	
			Time (hours)	Conditions
1	unlimited	≤30°C / 85% RH	168+5/-0	85°C / 85% RH

• Thermal Resistance

Table 8 . Thermal Resistance - Junction to Thermal Pad

Thermal Resistance from Junction to Thermal Pad	Units
10	°C / W

Reliability Test Items

Table 9. Reliability Test on Edixeon® Federal

Stress Test	Stress Conditions	Stress Duration	Failure Criteria
Room Temperature Operating Life	55 °C, I _f =DC max ^[1]	1000 hours	Note 2
High Temperature High Humidity Operating Life	85 °C / 85%RH, I _f =DC max ^[1]	1000 hours	Note 2
High Temperature Operating Life	85 °C, I _f =DC max ^[1]	1000 hours	Note 2
Low Temperature Operating Life	-40 °C, I _f =DC max ^[1]	1000 hours	Note 2
High Temperature Storage Life	150 °C	1000 hours	Note 2
Low Temperature Storage Life	-40 °C	1000 hours	Note 2
Non-Operating Thermal Shock	-40 / 125°C, 20 min dwell<10 sec transfer	500 cycles	No catastrophic
Mechanical Shock	1500 G, 0.5 msec pulse, 5 shocks each 6 axis	N/A	No catastrophic
Free Drop	On concrete from 1.2 m, 3X	N/A	No catastrophic
Variable Vibration Frequency	10-2000-10 Hz, log or linear sweep rate, 20 G about 1 min, 1.5 mm, 3X/axis	N/A	No catastrophic
Solder Heat Resistance (SHR)	Three JEDEC Pb-free reflow profile	N/A	No catastrophic

Notes:

1.DC max is defined to be 350mA and 700mA for 1W and 3W Edixeon® Federal respectively.

2. Failure Criteria:

- Electrical failures: VF shifts >= 10%
- Light Output Degradation: Percentage level shift >= 50% at 1,000hrs or 500cycle
- Visual failures: Broken or damaged package on lens or substrate

Color Spectrum and Radiation Pattern

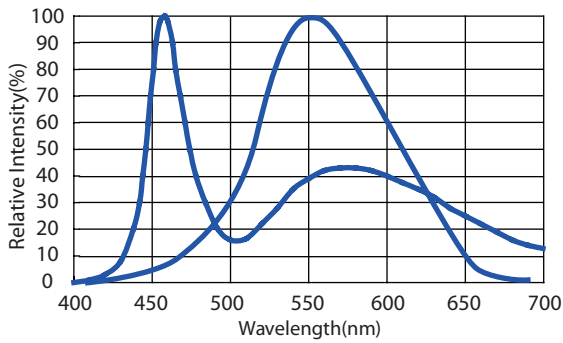

Figure 4. Color Spectrum for Cool White at $T_j=25^\circ\text{C}$

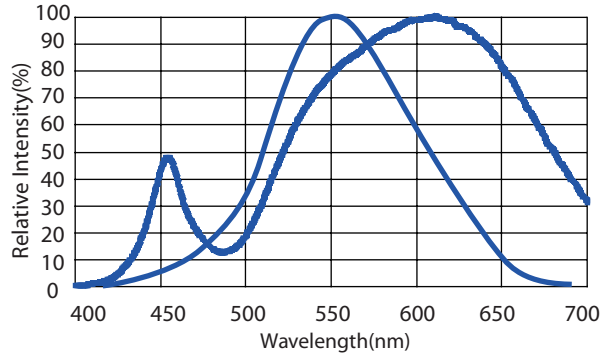

Figure 5. Color Spectrum for Neutral White and Warm White at $T_j=25^\circ\text{C}$.

• Radiation Pattern

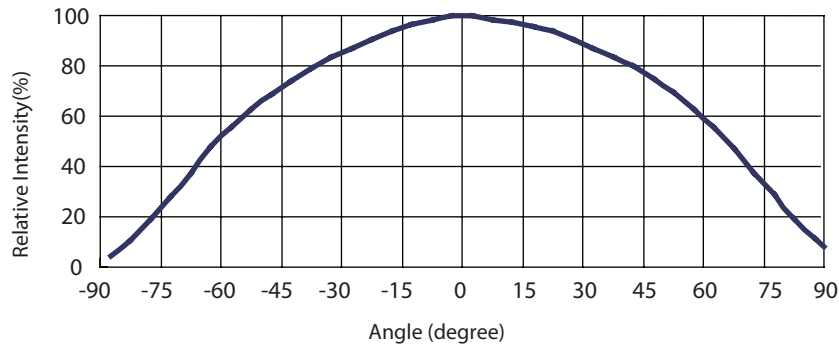

Figure 6. Emission Angle

Optical and Electric Curves

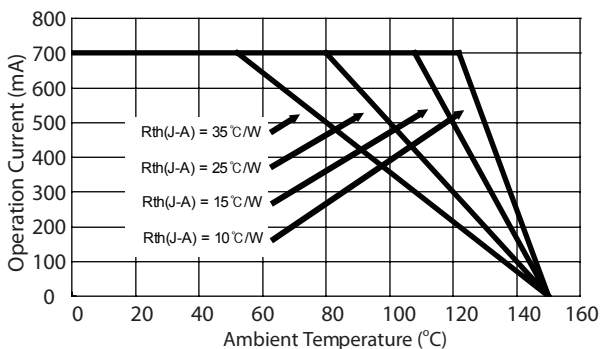

Figure 7. Maximum Operating Current vs Ambient Temperature for White, Blue, Green, Cyan, Royal Blue, Dental Blue and Ultraviolet at 700mA and $T_j = 150^\circ\text{C}$.

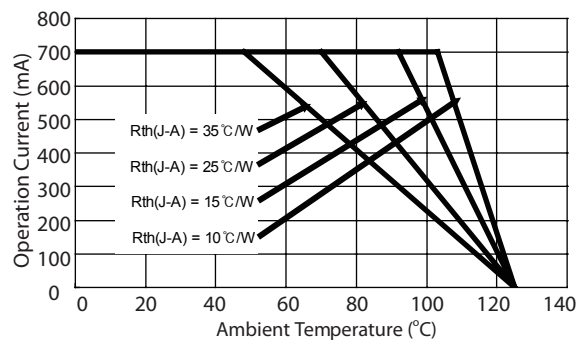

Figure 8. Maximum Operating Current vs Ambient Temperature for Red, Amber, Deep Red, Cherry Red. at 700mA and $T_j = 125^\circ\text{C}$.

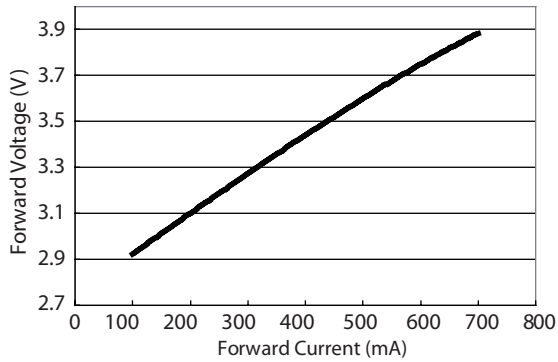

Figure 9. Forward voltage vs. forward current for White, Blue, Dental Blue and Royal Blue ,at $T_j = 25^\circ\text{C}$.

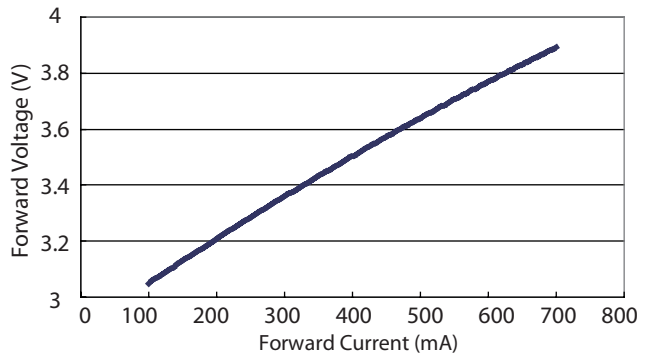

Figure 10. Forward voltage vs. forward current for True Green and Cyan ,at $T_j = 25^\circ\text{C}$.

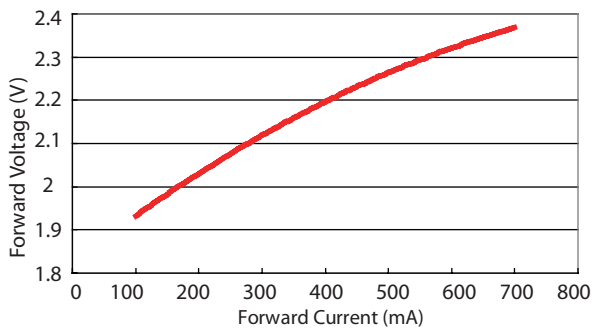

Figure 11. Forward voltage vs. forward current for Red and Amber ,at $T_j = 25^\circ\text{C}$.

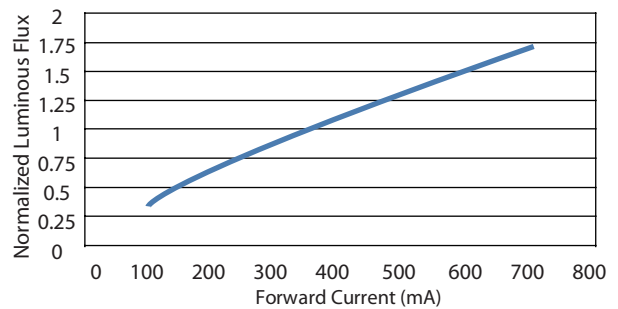

Figure 12. Relative luminous flux vs. forward current for Cool White, True Green, Blue, Cyan, Dental Blue and Royal Blue ,at $T_j = 25^\circ\text{C}$.

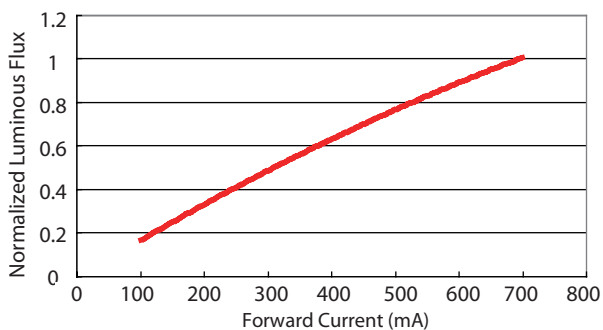

Figure 13. Relative luminous flux vs. forward current for Red and Amber ,at $T_j = 25^\circ\text{C}$.

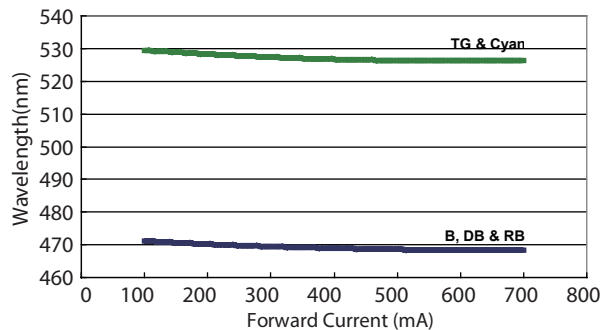

Figure 14. Wavelength length vs. forward current for True Green, Blue, Cyan, Royal Blue and Dental Blue ,at $T_j = 25^\circ\text{C}$.

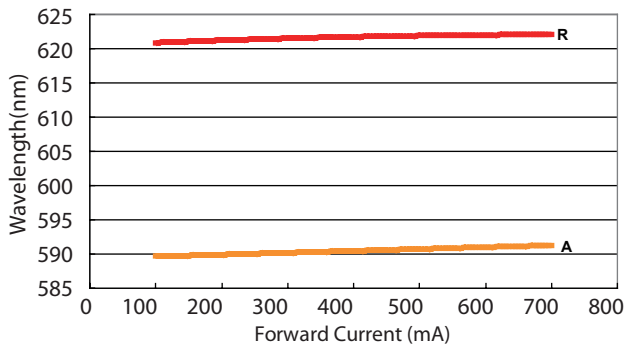

Figure 15. Wavelength length vs. forward current for Red and Amber, at $T_j = 25^\circ\text{C}$.

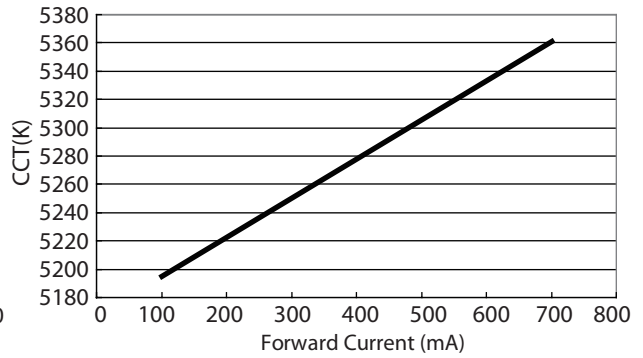

Figure 16. CCT vs. forward current for Cool White, at $T_j = 25^\circ\text{C}$.

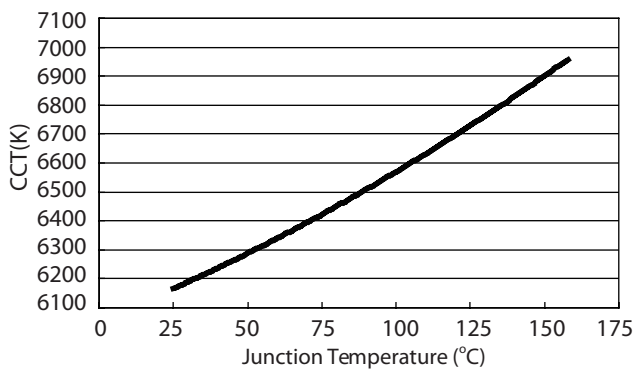

Figure 17. Typical CCT vs. junction temperature for Cool White.

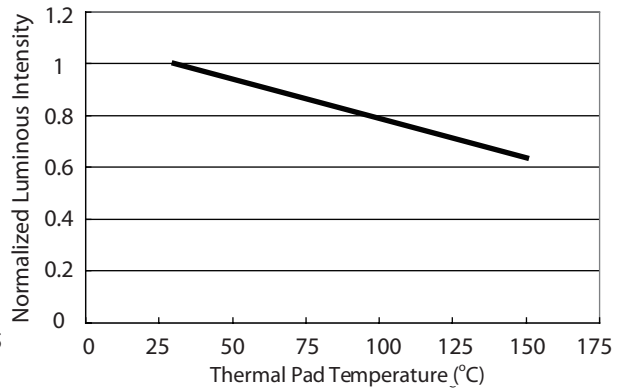

Figure 18. Relative luminous flux vs. thermal pad temperature for Cool White.

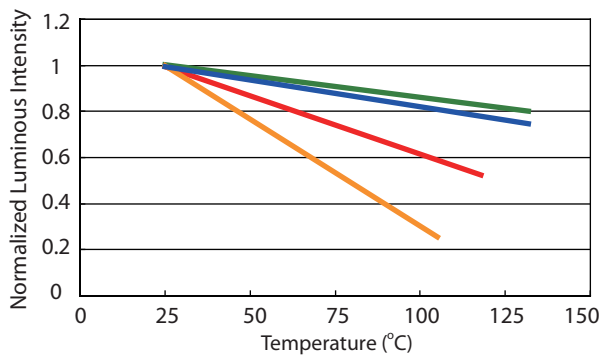

Figure 19. Relative luminous flux vs. thermal pad temperature for True Green, Blue, Red and Amber.

Reflow Profile

The following reflow profile is from IPC/JEDEC J-STD-020D which provided here for reference.

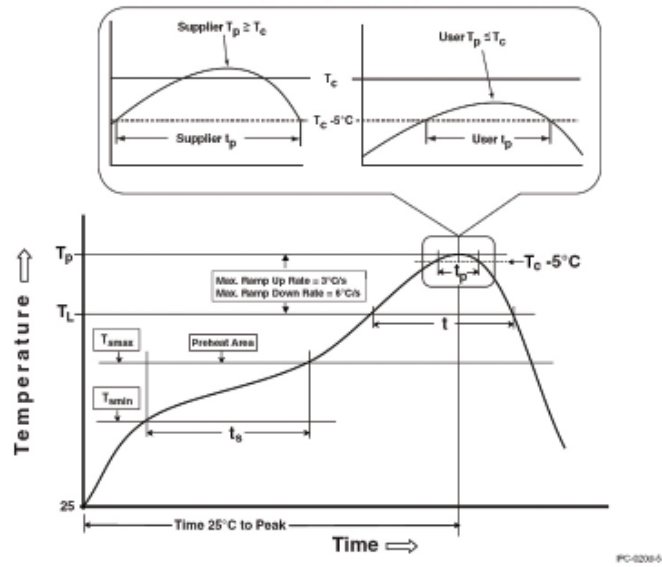

Figure 20. Reflow Profiles

Table 10. Table of Classification Reflow Profiles

Profile Feature	Sn-Pb Eutectic Assembly	Pb-Free Assembly
Preheat & Soak		
Temperature min (T _{smin})	100°C	150 °C
Temperature max (T _{smax})	150°C	200 °C
Time (T _{smin} to T _{smax}) (ts)	60-120 seconds	60-120 seconds
Average ramp-up rate (T _{smax} to T _p)	3°C/second max.	3 °C/second max.
Liquidous temperature (T _L)	183 °C	217 °C
Time at liquidous (t _L)	60-150 seconds	60-150 seconds
Peak package body temperature (T _p)*	230 °C ~235°C *	255 °C ~260 °C *
Classification temperature (T _c)	235°C	260 °C
Time (t _p)** within 5 °C of the specified classification temperature (T _c)	20** seconds	30** seconds
Average ramp-down rate (T _p to T _{smax})	6°C/second max.	6°C/second max.
Time 25°C to peak temperature	6 minutes max.	8 minutes max.

Notes:

- * Tolerance for peak profile temperature (T_p) is defined as a supplier minimum and a user maximum.
- ** Tolerance for time at peak profile temperature (t_p) is defined as a supplier minimum and a user maximum.

Product Packaging Information

• Tape and Reel Packaging

Dimensions. (Unit: mm)

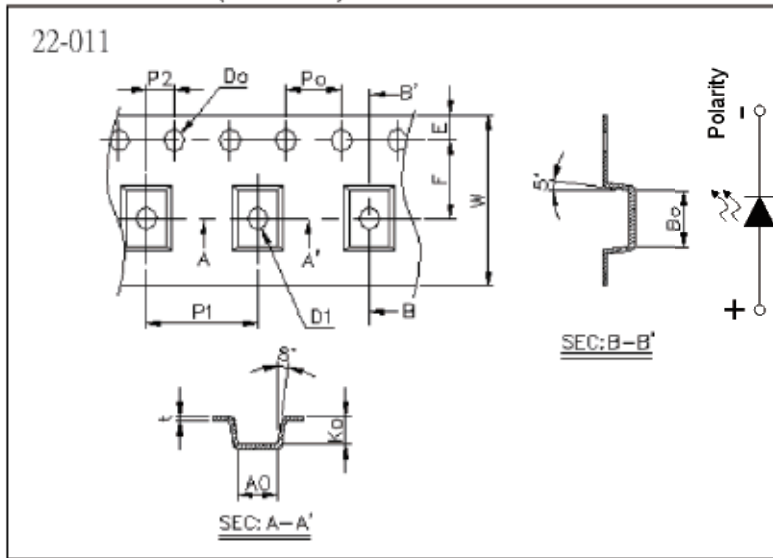

Item	Specification	Tol. (+/-)
W	12.00	±0.20
E	1.75	±0.10
F	5.50	±0.05
D0	1.50	±0.10, -0
D1	1.50	±0.10
P0	4.00	±0.05
P1	8.00	±0.10
P2	2.00	±0.05
P0 x 10	40.00	±0.20
t	0.25	±0.05
A0	3.32	±0.10
B0	4.87	±0.10
K0	2.27	±0.10

Figure 21. Federal Reel Dimensions.

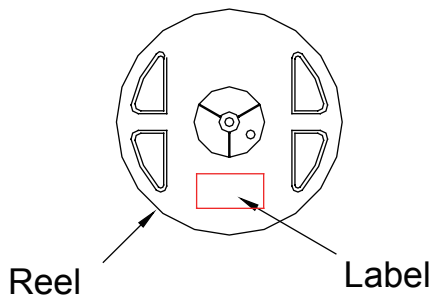

Item	Quantity	Total	Dimensions(mm)
Reel	250pcs	250pcs	Diameter=178
Box	4 reels	1,000pcs	240*235*67
Carton	5 boxes	5,000pcs	353*254*256

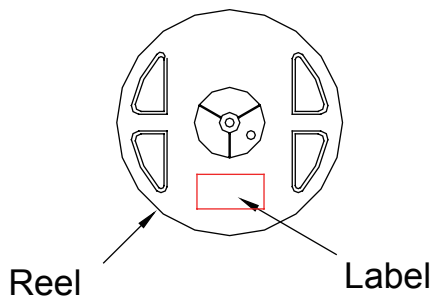

Item	Quantity	Total	Dimensions(mm)
Reel	1,000pcs	1,000pcs	Diameter=178
Box	5 reels	5,000pcs	240*235*67
Carton	5 boxes	25,000pcs	353*254*256

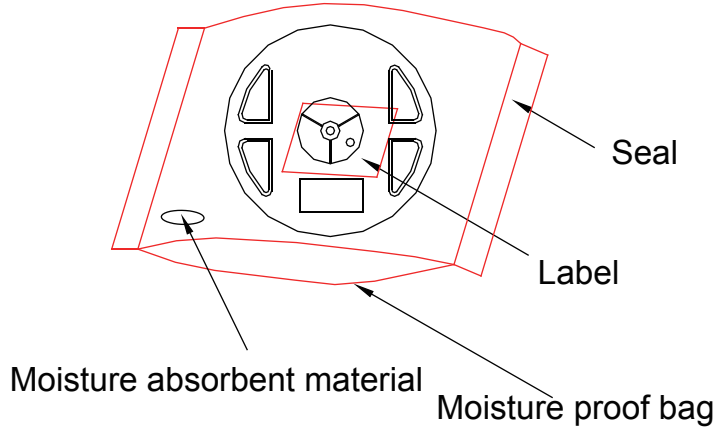

Package Label

Bin Groups

Table 11. Photometric Luminous Flux Bins for Cool White, Neutral White and Warm White

Group	Min. (lm)	Max. (lm)	Group	Min. (lm)	Max. (lm)
A	0.1	1.0	R	39.4	51.2
B	1.0	1.3	S1	51.2	58.8
C	1.3	1.7	S2	58.8	66.5
D	1.7	2.2	T1	66.5	70.0
E	2.2	2.9	T2	70.0	80.0
F	2.9	3.7	T3	80.0	86.5
G	3.7	4.8	U1	86.5	90
H	4.8	6.3	U2	90	100
J	6.3	8.2	U3	100	112.5
K	8.2	10.6	V	112.5	146.2
L	10.6	13.8	W	146.2	190.0
M	13.8	17.9	X	190.0	247.1
N	17.9	23.3	Y	247.1	321.2
P	23.3	30.3	Z	321.2	417.5
Q	30.3	39.4			

Table 12. Photometric Luminous Flux Bins for Single Color

Group	Min. (lm)	Max. (lm)	Group	Min. (lm)	Max. (lm)
A	0.1	1.0	N	17.9	23.3
B	1.0	1.3	P	23.3	30.3
C	1.3	1.7	Q	30.3	39.4
D	1.7	2.2	R	39.4	51.2
E	2.2	2.9	S	51.2	66.5
F	2.9	3.7	T	66.5	86.5
G	3.7	4.8	U	86.5	112.5
H	4.8	6.3	V	112.5	146.2
J	6.3	8.2	W	146.2	190.0
K	8.2	10.6	X	190.0	247.1
L	10.6	13.8	Y	247.1	321.2
M	13.8	17.9	Z	321.2	417.5

Table 13. Radiometric Power Bins (mW)

Group	Min. (lm)	Max. (lm)	Group	Min. (lm)	Max. (lm)
A	10.0	15.0	K	384.4	576.7
B	15.0	22.5	L	576.7	865.0
C	22.5	33.8	M	865.0	1,298
D	33.8	50.6	N	1,298	1,946
E	50.6	75.9	P	1,946	2,919
F	75.9	113.9	Q	2,919	4,379
G	113.9	170.9	R	4,379	6,569
H	170.9	256.3	S	6,569	9,853
J	256.3	384.4	T	9,853	14,779

• Cool White X, Y Groups

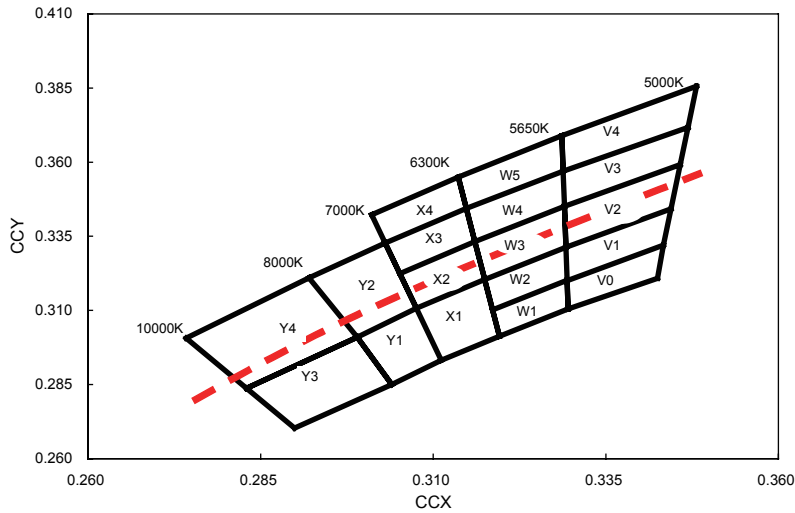

Figure 22. Cool White bin structure. The red line represents the blackbody locus on CIE 1931 graph.

Notes:

Edison maintains a tolerance of ± 0.005 on x, y color coordinates.

Group/ CCT(Typ)	X	Y	Group/ CCT(Typ)	X	Y	Group/ CCT(Typ)	X	Y	Group/ CCT(Typ)	X	Y
5300K V0	0.34335	0.33203	6000K W1	0.32939	0.32021	6650K X1	0.30755	0.31078	7500K Y1	0.30400	0.28500
	0.34250	0.32080		0.32954	0.31050		0.31745	0.32044		0.29900	0.30100
	0.32954	0.31050		0.31960	0.30130		0.31960	0.30130		0.30755	0.31078
	0.32939	0.32002		0.31861	0.31020		0.31116	0.29319		0.31116	0.29319
5300K V1	0.32922	0.33133	6000K W2	0.32922	0.33133	6650K X2	0.30755	0.31078	7500K Y2	0.29900	0.30100
	0.34444	0.34423		0.32939	0.32021		0.30517	0.32239		0.29200	0.32100
	0.34335	0.33203		0.31861	0.31020		0.31604	0.33322		0.30305	0.33271
	0.32939	0.32002		0.31747	0.32044		0.31747	0.32044		0.30755	0.31078
5300K V2	0.32922	0.33133	6000K W3	0.32901	0.34509	6650K X3	0.30517	0.32239	9000K Y3	0.30400	0.28500
	0.32901	0.34509		0.32922	0.33133		0.30305	0.33271		0.28992	0.27032
	0.34578	0.35919		0.31747	0.32044		0.31479	0.34444		0.28297	0.28377
	0.34444	0.34423		0.31604	0.33322		0.31604	0.33322		0.29900	0.30100
5300K V3	0.32901	0.34509	6000K W4	0.32901	0.34509	6650K X4	0.30305	0.33271	9000K Y4	0.29200	0.32100
	0.32882	0.35692		0.31604	0.33322		0.30109	0.34224		0.27424	0.30067
	0.34690	0.37174		0.31479	0.34444		0.31362	0.35499		0.28297	0.28377
	0.34578	0.35919		0.32882	0.35692		0.31479	0.34444		0.29900	0.30100
5300K V4	0.32882	0.35692	6000K W5	0.31479	0.34444						
	0.32864	0.36895									
	0.34815	0.38563									
	0.34690	0.37174									

• Neutral White X,Y Groups

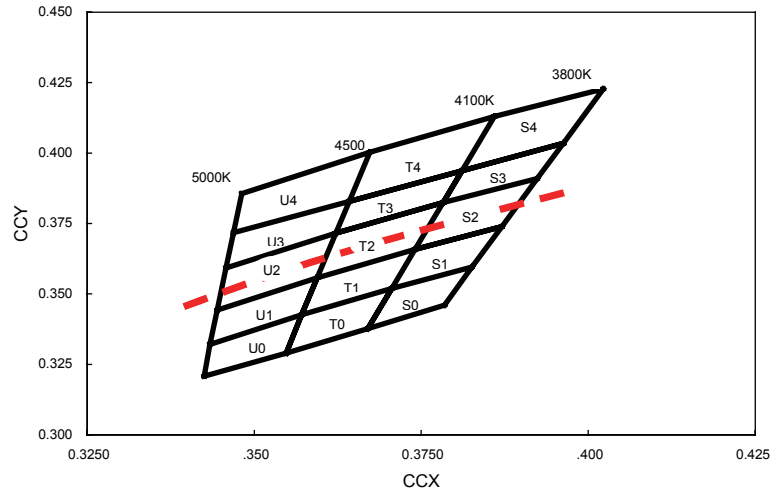

Figure 23. Neutral White bin structure. The red line represents the blackbody locus on CIE 1931 graph.

Note:

Edison maintains a tolerance of ± 0.005 on x, y color coordinates.

Group/ CCT(Typ)	X	Y	Group/ CCT(Typ)	X	Y	Group/ CCT(Typ)	X	Y
S0 3900K	0.382598	0.359515	T0 4300K	0.370582	0.351953	U0 4750K	0.357079	0.342581
	0.378500	0.346000		0.367000	0.337700		0.354800	0.329000
	0.367000	0.337700		0.354800	0.329000		0.342500	0.320800
	0.370582	0.351953		0.357079	0.342581		0.343352	0.332034
S1 3900K	0.374075	0.365822	T1 4300K	0.359401	0.355699	U1 4750K	0.344443	0.344232
	0.387071	0.373899		0.357079	0.342581		0.343352	0.332034
	0.382598	0.359515		0.370582	0.351953		0.357079	0.342581
	0.370582	0.351953		0.374075	0.365822		0.359401	0.355699
S2 3900K	0.378264	0.382458	T2 4300K	0.362219	0.371616	U2 4750K	0.362219	0.371616
	0.392368	0.390932		0.378264	0.382458		0.359401	0.355699
	0.387071	0.373899		0.374075	0.365822		0.344443	0.344232
	0.374075	0.365822		0.359401	0.355699		0.345781	0.359190
S3 3900K	0.378264	0.382458	T3 4300K	0.364212	0.382878	U3 4750K	0.364212	0.382878
	0.381106	0.393747		0.381106	0.393747		0.362219	0.371616
	0.396279	0.403508		0.378264	0.382458		0.345781	0.359190
	0.392368	0.390932		0.362219	0.371616		0.346904	0.371742
S4 3900K	0.385953	0.412995	T4 4300K	0.367294	0.400290	U4 4750K	0.364212	0.382878
	0.402270	0.422776		0.385953	0.412995		0.367294	0.400290
	0.396279	0.403508		0.381106	0.393747		0.348147	0.385629
	0.381106	0.393747		0.364212	0.382878		0.346904	0.371742

• Warm White X,Y Groups

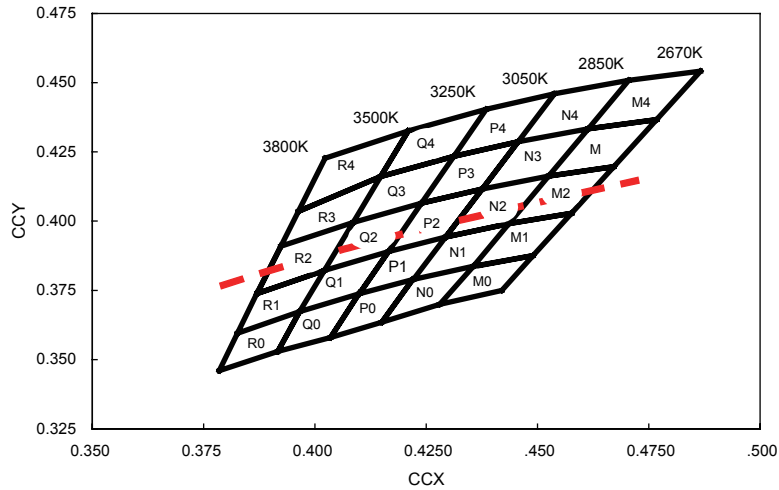

Figure 24. Warm White bin structure. The red line represents the blackbody locus on CIE 1931 graph.

Note:

Edison maintains a tolerance of ± 0.005 on x, y color coordinates.

Group/ CCT(Typ)	X	Y	Group/ CCT(Typ)	X	Y	Group/ CCT(Typ)	X	Y
M0	0.43700	0.38400	N0	0.43559	0.38371	P0	0.42200	0.37900
	0.44899	0.38752		0.42800	0.37000		0.41500	0.36350
2700K	0.44200	0.37500	2900K	0.41500	0.36350	3150K	0.40350	0.35800
	0.42800	0.37000		0.42200	0.37900		0.41000	0.37400
M1	0.44360	0.39911	N1	0.42937	0.39428	P1	0.42937	0.39428
	0.45766	0.40287		0.44360	0.39911		0.42212	0.37895
2700K	0.44899	0.38752	2900K	0.43559	0.38371	3150K	0.41000	0.37381
	0.43559	0.38371		0.42212	0.37895		0.41649	0.38900
M2	0.45251	0.41624	N2	0.43758	0.41163	P2	0.42396	0.40647
	0.46713	0.41963		0.42937	0.39428		0.43758	0.41163
2700K	0.45766	0.40287	2900K	0.44360	0.39911	3150K	0.42937	0.39428
	0.44360	0.39911		0.45251	0.41624		0.41649	0.38900
M3	0.46140	0.43333	N3	0.46140	0.43333	P3	0.43119	0.42339
	0.47673	0.43663		0.45251	0.41624		0.44564	0.42868
2700K	0.46713	0.41963	2900K	0.43758	0.41163	3150K	0.43758	0.41163
	0.45251	0.41624		0.44564	0.42868		0.42396	0.40647
M4	0.47051	0.45083	N4	0.45382	0.44598	P4	0.43846	0.44040
	0.48665	0.45419		0.47051	0.45083		0.45382	0.44598
2700K	0.47673	0.43663	2900K	0.46140	0.43333	3150K	0.44564	0.42868
	0.46140	0.43333		0.44564	0.42868		0.43119	0.42339

• **Forward Voltage Bins**

Table 14. Forward Voltage Bins for White, True Green, Blue, Dental Blue, Royal Blue, Cyan and Ultraviolet

V _F (V)	
V01	2.8 — 3.1
V02	3.1 — 3.4
V03	3.4 — 3.7
V04	3.7 — 4.0
V05	4.0 — 4.3
V06	4.3 — 4.6
V07	4.6 — 4.9
V08	4.9 — 5.2

Table 15. Forward Voltage Bins for Red, Amber, Deep Red and Cherry Red

V _F (V)	
V01	2.0 — 2.25
V02	2.25 — 2.5
V03	2.5 — 2.75
V04	2.75 — 3.0
V05	3.0 — 3.25

• **Dominant/Peak Wavelength Bin Structure**

Table 16. Dominant/Peak Wavelength Bin Structure

Group	λ _d (nm), λ _p (nm)	Group	λ _d (nm), λ _p (nm)	Group	λ _d (nm), λ _p (nm)
Ultraviolet[1]	390 — 410	V	455 — 460	Deep Red	650 — 670
V	390 — 395	W	460 — 465	Cherry Red	730 — 750
W	395 — 400	X	465 — 470	IR 850	840 — 860
X	400 — 405	Y	470 — 475	IR 940	930 — 950
Y	405 — 410	True Green	515 — 535		
Royal Blue[1]	440 — 460	V	515 — 520		
V	440 — 445	W	520 — 525		
W	445 — 450	X	525 — 530		
X	450 — 455	Y	530 — 535		
Y	455 — 460	Amber	585 — 595		
Dental Blue[1]	450 — 470	X	585 — 588		
W	450 — 455	Y	588 — 591		
X	455 — 460	Z1	591 — 593		
Y	460 — 465	Z2	593 — 595		
Z	465 — 470	Red	620 — 630		
Blue	455 — 475	X	620 — 630		

• Dominant Wavelength and CIE Coordinate

Table 17. Dominant/Peak Wavelength Bin Structure

	Royal Blue	Wavelength/nm @ 350 mA			CIE color coordinates		
		Min. λ_p	Max. λ_p	Avg. λ_p	saturation	average x	average y
	<i>Royal Blue W</i>	440	445	442.5	99.6%	0.1645	0.0114
	<i>Royal Blue X</i>	445	450	447.5	99.6%	0.1597	0.0169
	<i>Royal Blue Y</i>	450	455	452.5	99.2%	0.1554	0.0226
	<i>Royal Blue Z</i>	455	460	457.5	98.7%	0.1500	0.0299
	Blue	Wavelength/nm @ 350 mA			CIE color coordinates		
		Min. λ_d	Max. λ_d	Avg. λ_d	saturation	average x	average y
	<i>Blue V</i>	455	460	457.5	98.7%	0.1500	0.0299
	<i>Blue W</i>	460	465	462.5	98.2%	0.1434	0.0396
	<i>Blue X</i>	465	470	467.5	96.8%	0.1367	0.0568
	<i>Blue Y</i>	470	475	472.5	95.8%	0.1263	0.0817
	Green	Wavelength/nm @ 350 mA			CIE color coordinates		
		Min. λ_d	Max. λ_d	Avg. λ_d	saturation	average x	average y
	<i>Green V</i>	515	520	517.5	73.0%	0.1307	0.6939
	<i>Green W</i>	520	525	522.5	75.0%	0.1538	0.7077
	<i>Green X</i>	525	530	527.5	80.0%	0.1744	0.7201
	<i>Green Y</i>	530	535	532.5	83.5%	0.2003	0.7181
	Amber	Wavelength/nm @ 350 mA			CIE color coordinates		
		Min. λ_d	Max. λ_d	Avg. λ_d	saturation	average x	average y
	<i>Amber X</i>	585	588	586.5	99.3%	0.5480	0.4490
	<i>Amber Y</i>	588	591	589.5	99.3%	0.5631	0.4339
	<i>Amber Z1</i>	591	593	593.0	88.8%	0.5864	0.4145
	<i>Amber Z2</i>	593	595	593.0	89.5%	0.5952	0.4059
	Red	Wavelength/nm @ 350 mA			CIE color coordinates		
		Min. λ_d	Max. λ_d	Avg. λ_d	saturation	average x	average y
	<i>Red</i>	620	630	625	99.8%	0.7011	0.2982