

CoolFin® Giga - High Power heat pipe LED Cooler with stack fins

Features & Benefits

- For high bay or high mast application up to 100,000lm
- For horticulture top lighting up to 1,500 μmol/s
- 4 high power COB or LOB LED engines size 28x28mm or 38x38mm
- Rth 0.1°C/W - Pd 406W
- Ultra low profile - size W468 x L446 x H226mm
- Full accessory kit with LED cooler, PSU mounting plates & lens holder
- Other accessories like COB/LOB holder & lenses separate available

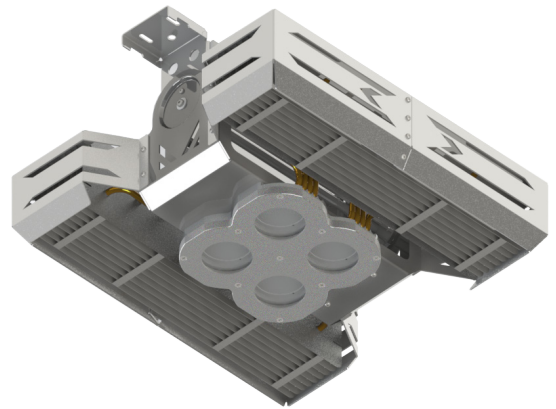

Order Information

Example : CoolFin® Giga

CoolFin® Giga **1**

Complete kit with:

- CoolFin® Giga high power LED cooler
- 2 modular PSU mounting plates

1 Handle length

N/A: Short handle (non-tiltable)
Tilt: Long handle (tiltable)

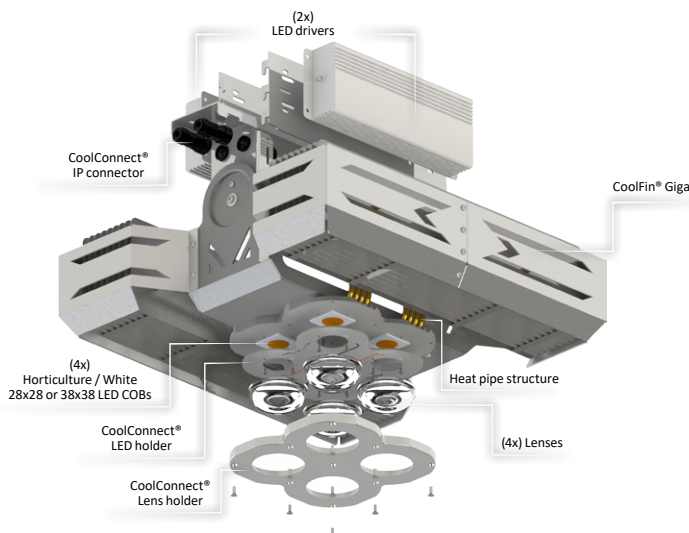

Example : CoolConnect® LensMount 2x2-01

CoolConnect® LensMount 2x2- **1**

1 Lens holder type

01: for Ledil Stella HB-WWW lenses
02: for CoolView® lenses

Example : CoolConnect® holder 2x2HC-01

CoolConnect® holder 2x2HC- **1**

1 LED holder type

01: 4 times 28x28 COB/LOB
02: 4 times 38x38 COB/LOB

Example : CoolConnect® IP Connector M20 3P

CoolConnect® IP Connector M20 **1**

1 Number of poles

2P: 2 poles
3P: 3 poles
5P: 5 poles

CoolFin® Giga - High Power heat pipe LED Cooler with stack fins

Product Details

Model n°	CoolFin® Giga	CoolFin® Giga Tilt
Dimension (mm) ^{*1}	W468mm x L446mm x H226mm	W468mm x L446mm x H394mm
Weight (gr)	6900	7830
Cooling Surface (mm ²)	1,935,738	
Thermal Resistance (°C/W) ^{*2}	0.1	
Power Pd (W) ^{*3}	406	
Surface finishing	16 sintered heat pipes with stack fin	

^{*1} 3D files are available in ParaSolid, STP and IGS on request

^{*2} The thermal resistance Rth is determined with a calibrated heat source of 30mm x 30mm central placed on the heat sink, Tamb 40° and an open environment. Reference data @ heat sink to ambient temperature rise Ths-amb 50°C
 The thermal resistance of a LED cooler is not a fix value and will vary with the applied dissipated power Pd

^{*3} Dissipated power Pd. Reference data @ heat sink to ambient temperature rise Ths-amb 50°C
 The maximal dissipated power needs to be verified in function of required case temperature Tc or junction temperature Tj and related to the estimated ambient temperature where the light fixture will be placed
 Please be aware the dissipated power Pd is not the same as the electrical power Pe of a LED module

To calculate the dissipated power please use the following formula: $Pd = Pe \times (1 - \eta L)$

Pd - Dissipated power

Pe - Electrical power

ηL = Light efficiency of the LED module

Notes:

- MechaTronix reserves the right to change products or specifications without prior notice.
- Mentioned models are an extraction of full product range.
- For specific mechanical adaptations please contact MechaTronix.