



24-Bit A/D Flash MCU

BH66F5362

Revision: V1.30 Date: November 14, 2023

www.holtek.com

Table of Contents

Features	7
CPU Features	7
Peripheral Features.....	7
General Description	8
Block Diagram	9
Pin Assignment	9
Pin Description	10
Absolute Maximum Ratings	14
D.C. Characteristics	15
Operating Voltage Characteristics.....	15
Operating Current Characteristics.....	15
Standby Current Characteristics	16
A.C. Characteristics	17
High Speed Internal Oscillator – HIRC – Frequency Accuracy	17
Low Speed Internal Oscillator Characteristics – LIRC	17
Low Speed Crystal Oscillator Characteristics – LXT.....	17
Operating Frequency Characteristic Curves	18
System Start Up Time Characteristics	18
Input/Output Characteristics	19
Input/Output (without Multi-power) D.C Characteristics	19
Input/Output (with Multi-power) D.C Characteristics	20
12-Bit A/D Converter Electrical Characteristics	21
Internal Reference Voltage Electrical Characteristics	22
Comparator Electrical Characteristics	23
Memory Electrical Characteristics	24
LVD/LVR Electrical Characteristics	24
LCD Electrical Characteristics	25
24-Bit ADC Characteristics	25
Effective Number of Bits (ENOB).....	27
I²C Electrical Characteristics	28
Power-on Reset Characteristics	29
System Architecture	30
Clocking and Pipelining.....	30
Program Counter.....	31
Stack	31
Arithmetic and Logic Unit – ALU	32

Flash Program Memory	33
Structure.....	33
Special Vectors	33
Look-up Table.....	33
Table Program Example	34
In Circuit Programming – ICP	35
On-Chip Debug Support – OCDS	36
In Application Programming – IAP	36
RAM Data Memory	52
Structure.....	52
Data Memory Addressing.....	53
General Purpose Data Memory	53
Special Purpose Data Memory	53
Special Function Register Description	55
Indirect Addressing Registers – IAR0, IAR1, IAR2	55
Memory Pointers – MP0, MP1L/MP1H, MP2L/MP2H.....	55
Program Memory Bank Pointer – PBP.....	56
Accumulator – ACC.....	57
Program Counter Low Register – PCL.....	57
Look-up Table Registers – TBLP, TBHP, TBLH.....	57
Status Register – STATUS.....	57
EEPROM Data Memory	59
EEPROM Data Memory Structure	59
EEPROM Registers	59
Reading Operation from the EEPROM	61
Page Erase Operation to the EEPROM	62
Write Operation to the EEPROM	63
Write Protection.....	64
EEPROM Interrupt	64
Programming Considerations.....	64
Oscillators	67
Oscillator Overview	67
System Clock Configurations	68
External Crystal/Ceramic Oscillator – HXT	68
Internal High Speed RC Oscillator – HIRC	69
External 32.768kHz Crystal Oscillator – LXT	69
Internal 32kHz Oscillator – LIRC.....	70
Operating Modes and System Clocks	71
System Clocks	71
System Operation Modes.....	72
Control Registers	73
Operating Mode Switching	75

Standby Current Considerations	79
Wake-up	79
Watchdog Timer	80
Watchdog Timer Clock Source	80
Watchdog Timer Control Register	80
Watchdog Timer Operation	81
Reset and Initialisation	82
Reset Functions	82
Reset Initial Conditions	87
Input/Output Ports	92
Pull-high Resistors	92
Port A Wake-up	93
I/O Port Control Registers	93
I/O Port Power Source Control	94
I/O Port Source Current Control	94
Pin-shared Functions	96
I/O Pin Structures	104
READ PORT Function	105
Programming Considerations	106
Timer Modules – TM	107
Introduction	107
TM Operation	107
TM Clock Source	107
TM Interrupts	108
TM External Pins	108
Programming Considerations	109
Standard Type TM – STM	110
Standard TM Operation	110
Standard Type TM Register Description	110
Standard Type TM Operation Modes	115
Periodic Type TM – PTM	125
Periodic TM Operation	126
Periodic Type TM Register Description	126
Periodic Type TM Operation Modes	131
12-Bit Analog to Digital Converter – ADC	140
A/D Converter Overview	140
Registers Descriptions	141
A/D Converter Reference Voltage	144
A/D Converter Input Signals	144
A/D Conversion Operation	145
Conversion Rate and Timing Diagram	146
Summary of A/D Conversion Steps	147
Programming Considerations	148

A/D Transfer Function	148
A/D Programming Examples	149
Serial Interface Module – SIM	150
SPI Interface	150
I ² C Interface	159
UART Interfaces	168
UART External Pins	168
UART Data Transfer Scheme.....	168
UART Status and Control Registers.....	169
Baud Rate Generator	176
UART Setup and Control.....	178
UART Transmitter.....	179
UART Receiver	180
Managing Receiver Errors	182
UART Interrupt Structure.....	182
UART Power Down and Wake-up.....	184
Comparators	185
Comparator Operation	185
Comparator Registers	185
Input Offset Calibration	187
Comparator Interrupt.....	187
Programming Considerations.....	187
16-bit Multiplication Division Unit – MDU	188
MDU Registers.....	188
MDU Operation	189
Cyclic Redundancy Check – CRC	191
CRC Registers	191
CRC Operation.....	192
CRC Computation	192
Software Controlled LCD Driver.....	194
LCD Operation	194
LCD Control Registers	194
Interrupts	195
Interrupt Registers.....	195
Interrupt Operation	202
External Interrupts.....	203
Comparator Interrupt.....	204
A/D Converter Interrupt	204
Multi-function Interrupts.....	204
Timer Module Interrupts	205
LVD Interrupt.....	205
EEPROM Interrupt	205
SIM Interrupt	205

UART Transfer Interrupt.....	206
Time Base Interrupts	206
Interrupt Wake-up Function.....	208
Programming Considerations.....	208
Low Voltage Detector – LVD	209
LVD Register	209
LVD Operation.....	209
24-Bit Analog to Digital Converter	210
24-Bit A/D converter Registers.....	211
Internal Power Supply	212
Reference Voltages.....	212
Power and Reference Control.....	214
Oscillators	214
Input Signal Gain Control Amplifier – PGA.....	215
Analog to Digital Converter Operation	217
External Interface Communication	223
Configuration Options.....	226
Application Circuits.....	227
Instruction Set.....	228
Introduction	228
Instruction Timing	228
Moving and Transferring Data.....	228
Arithmetic Operations.....	228
Logical and Rotate Operation	229
Branches and Control Transfer	229
Bit Operations	229
Table Read Operations	229
Other Operations.....	229
Instruction Set Summary	230
Table Conventions.....	230
Extended Instruction Set.....	232
Instruction Definition.....	234
Extended Instruction Definition	243
Package Information	250
48-pin LQFP (7mm×7mm) Outline Dimensions	251

Features

CPU Features

- Operating Voltage
 - ♦ $f_{SYS}=8\text{MHz}$: 1.8V~5.5V
 - ♦ $f_{SYS}=12\text{MHz}$: 2.7V~5.5V
 - ♦ $f_{SYS}=16\text{MHz}$: 3.3V~5.5V
- Up to 0.25 μs instruction cycle with 16MHz system clock at $V_{DD}=5\text{V}$
- Power down and wake-up functions to reduce power consumption
- Oscillators
 - ♦ External High Speed Crystal – HXT
 - ♦ External Low Speed 32.768kHz Crystal – LXT
 - ♦ Internal High Speed 8/12/16MHz RC – HIRC
 - ♦ Internal 32kHz RC – LIRC
- Fully integrated internal oscillators require no external components
- Multi-mode operation: FAST, SLOW, IDLE and SLEEP
- All instructions executed in 1~3 instruction cycles
- Table read instructions
- 115 powerful instructions
- 16-level subroutine nesting
- Bit manipulation instruction

Peripheral Features

- Flash Program Memory: 16K \times 16
- RAM Data Memory: 2048 \times 8
- True EEPROM Memory: 1024 \times 8
- In Application Programming – IAP
- Watchdog Timer function
- Up to 32 bidirectional I/O lines
- 2 differential or 4 single-end channel 24-bit resolution Delta Sigma A/D converter
- Programmable I/O source current for LED applications
- Software controlled 4-SCOM line LCD driver with 1/2 bias
- Four external interrupt lines shared with I/O pins
- Multiple Timer Modules for time measurement, input capture, compare match output, PWM output function or single pulse output function
 - ♦ Dual 16-bit STM (STM0~STM1)
 - ♦ Dual 10-bit PTM (PTM0~PTM1)
 - ♦ Dual 16-bit PTM (PTM2~PTM3)
- Serial Interface Module – SIM for SPI or I²C
- Two fully-duplex Universal Asynchronous Receiver and Transmitter Interfaces – UARTs
- Dual Time Base functions for generation of fixed time interrupt signals
- One comparator function

- 9 external channel 12-bit resolution A/D converter with Internal Reference Voltage V_R
- Integrated Multiplier/Divider Unit – MDU
- Integrated 16-bit Cyclic Redundancy Check function – CRC
- Internal On-Chip Debug Support function – OCDS
- Low Voltage Reset function – LVR
- Low Voltage Detect function – LVD
- Package type: 48-pin LQFP

General Description

The device is a Flash Memory A/D 8-bit high performance RISC architecture microcontroller, designed for applications that interface directly to analog signals. Offering users the convenience of Flash Memory multi-programming features, this device also includes a wide range of functions and features. Other memory includes an area of RAM Data Memory as well as an area of true EEPROM memory for storage of non-volatile data such as serial numbers, calibration data etc.

Analog features include a multi-channel 12-bit A/D converter and one comparator functions, as well as a 24-bit Delta Sigma A/D converter which includes a programmable gain amplifier and is designed for applications that interface differentially to analog signals. Multiple and extremely flexible Timer Modules provide timing, pulse generation and PWM generation functions. Communication with the outside world is catered for by including fully integrated SPI, I²C and UART interface functions, these popular interfaces which provide designers with a means of easy communication with external peripheral hardware. Protective features such as an internal Watchdog Timer, Low Voltage Reset and Low Voltage Detector coupled with excellent noise immunity and ESD protection ensure that reliable operation is maintained in hostile electrical environments.

A full choice of external, internal, high and low oscillators are provided including two fully integrated system oscillators which require no external components for its implementation. The ability to operate and switch dynamically between a range of operating modes using different clock sources gives users the ability to optimise microcontroller operation and minimise power consumption.

The inclusion of flexible I/O programming features, a 16-bit MDU, Time-Base functions along with many other features ensure that the device will find excellent use in applications such as electronic scales, blood pressure meters, blood glucose meters, pressure switches, industrial control, instruments and other high accuracy measuring products.

Block Diagram

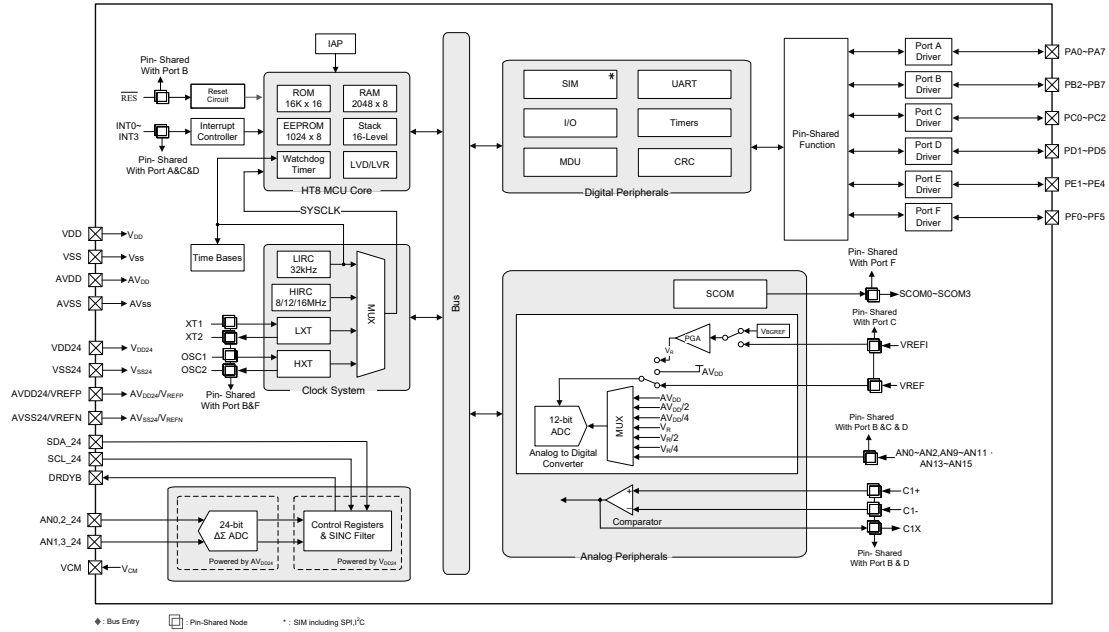

Pin Assignment

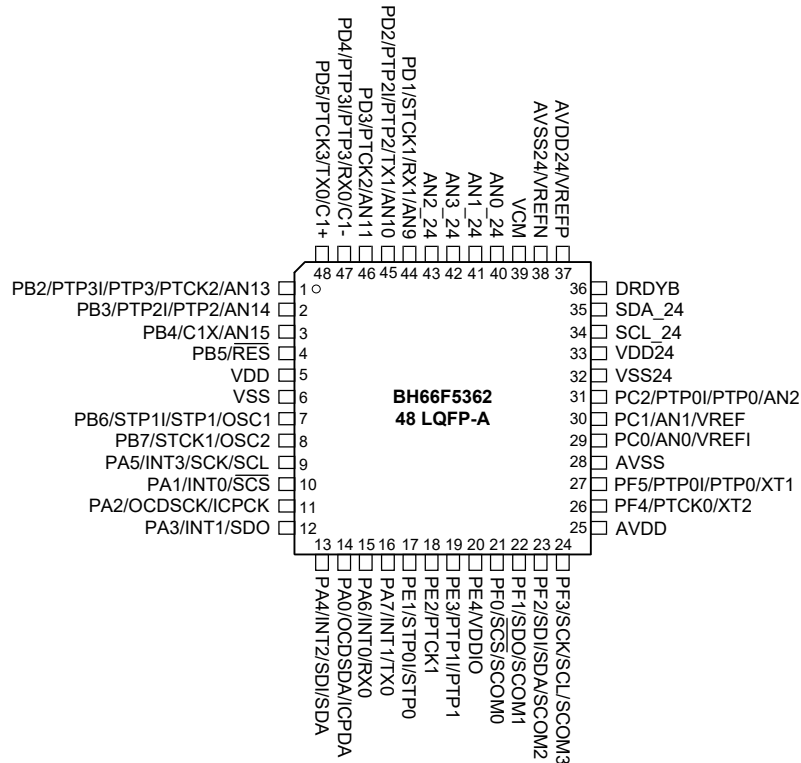

Note: 1. If the pin-shared pin functions have multiple outputs, the desired pin-shared function is determined by the corresponding software control bits.

2. The OCSDSA and OCDSCK pins are supplied as OCDS dedicated pins.
3. For the unbonded lines, PB0~PB1, PC3~PC7, PD0, PD6,PE0 and PF6~PF7, the line status should be properly configured to avoid unwanted power consumption resulting from floating input conditions. Refer to the “Standby Current Considerations” and “Input/Output Ports” sections for more details.

Pin Description

The function of each pin is listed in the following table, however the details behind how each pin is configured is contained in other sections of the datasheet. Note that where more than one package type exists the table will reflect the situation for the larger package type.

Pin Name	Function	OPT	I/T	O/T	Description
PA0/OCSDSA/ICPDA	PA0	PAWU PAPU	ST	CMOS	General purpose I/O. Register enabled pull-up and wake-up
	OCSDSA	—	ST	CMOS	OCDS data/address pin
	ICPDA	—	ST	CMOS	ICP data/address pin
PA1/INT0/ $\overline{\text{SCS}}$	PA1	PAWU PAPU PAS0	ST	CMOS	General purpose I/O. Register enabled pull-up and wake-up
	INT0	INTEG INTC0 PAS0 IFS2	ST	—	External Interrupt input 0
	$\overline{\text{SCS}}$	PAS0 IFS2	ST	CMOS	SIM SPI slave select pin
PA2/OCDSCK/ICPCK	PA2	PAWU PAPU	ST	CMOS	General purpose I/O. Register enabled pull-up and wake-up
	OCDSCK	—	ST	—	OCDS clock input
	ICPCK	—	ST	CMOS	ICP clock pin
PA3/INT1/SDO	PA3	PAWU PAPU PAS0	ST	CMOS	General purpose I/O. Register enabled pull-up and wake-up
	INT1	PAS0 INTEG INTC0 IFS2	ST	—	External Interrupt input 1
	SDO	PAS0	—	CMOS	SIM SPI serial data output
PA4/INT2/SDI/SDA	PA4	PAWU PAPU PAS1	ST	CMOS	General purpose I/O. Register enabled pull-up and wake-up
	INT2	PAS1 INTEG INTC3 IFS2	ST	—	External Interrupt input 2
	SDI	PAS1 IFS2	ST	—	SIM SPI serial data input
	SDA	PAS1 IFS2	ST	NMOS	SIM I ² C data line

Pin Name	Function	OPT	I/T	O/T	Description
PA5/INT3/SCK/SCL	PA5	PAWU PAPU PAS1	ST	CMOS	General purpose I/O. Register enabled pull-up and wake-up
	INT3	PAS1 INTEG INTC3 IFS2	ST	—	External Interrupt input 3
	SCK	PAS1 IFS2	ST	CMOS	SIM SPI serial clock
	SCL	PAS1 IFS2	ST	NMOS	SIM I ² C clock line
PA6/INT0/RX0	PA6	PAWU PAPU PAS1	ST	CMOS	General purpose I/O. Register enabled pull-up and wake-up
	INT0	PAS1 INTEG INTC0 IFS2	ST	—	External Interrupt input 0
	RX0	PAS1 IFS3	ST	—	UART0 RX serial data input
PA7/INT1/TX0	PA7	PAWU PAPU PAS1	ST	CMOS	General purpose I/O. Register enabled pull-up and wake-up
	INT1	PAS1 INTEG INTC0 IFS2	ST	—	External Interrupt input 1
	TX0	PAS1	—	CMOS	UART0 TX serial data output
PB2/PTP3I/PTP3/PTCK2/ AN13	PB2	PBPU PBS0	ST	CMOS	General purpose I/O. Register enabled pull-up
	PTP3I	PBS0 IFS1	ST	—	PTM3 capture input
	PTP3	PBS0 IFS1	—	CMOS	PTM3 output
	PTCK2	PBS0 IFS0	ST	—	PTM2 clock input
	AN13	PBS0	AN	—	12-bit A/D Converter external analog input
PB3/PTP2I/PTP2/AN14	PB3	PBPU PBS0	ST	CMOS	General purpose I/O. Register enabled pull-up
	PTP2I	PBS0 IFS1	ST	—	PTM2 capture input
	PTP2	PBS0	—	CMOS	PTM2 output
	AN14	PBS0	AN	—	12-bit A/D Converter external analog input
PB4/C1X/AN15	PB4	PBPU PBS1	ST	CMOS	General purpose I/O. Register enabled pull-up
	C1X	PBS1	—	CMOS	Comparator 1 output
	AN15	PBS1	AN	—	12-bit A/D Converter external analog input
PB5/RES	PB5	PBPU RSTC	ST	CMOS	General purpose I/O. Register enabled pull-up
	RES	RSTC	ST	—	External reset input

Pin Name	Function	OPT	I/T	O/T	Description
PB6/STP11/STP1/OSC1	PB6	PBPU PBS1	ST	CMOS	General purpose I/O. Register enabled pull-up
	STP11	PBS1 IFS1	ST	—	STM1 capture input
	STP1	PBS1	—	CMOS	STM1 output
	OSC1	PBS1	HXT	—	HXT oscillator pin
PB7/STCK1/OSC2	PB7	PBPU PBS1	ST	CMOS	General purpose I/O. Register enabled pull-up
	STCK1	PBS1 IFS0	ST	—	STM1 clock input
	OSC2	PBS1	—	HXT	HXT oscillator pin
PC0/AN0/VREF1	PC0	PCPU PCS0	ST	CMOS	General purpose I/O. Register enabled pull-up
	AN0	PCS0	AN	—	12-bit A/D Converter external analog input
	VREF1	PCS0	AN	—	A/D Converter PGA input
PC1/AN1/VREF	PC1	PCPU PCS0	ST	CMOS	General purpose I/O. Register enabled pull-up
	AN1	PCS0	AN	—	12-bit A/D Converter external analog input
	VREF	PCS0	AN	—	12-bit A/D Converter reference voltage input
PC2/PTP0I/PTP0/AN2	PC2	PCPU PCS0	ST	CMOS	General purpose I/O. Register enabled pull-up
	PTP0I	PCS0 IFS1	ST	—	PTM0 capture input
	PTP0	PCS0	—	CMOS	PTM0 output
	AN2	PCS0	AN	—	12-bit A/D Converter external analog input
PD1/STCK1/RX1/AN9	PD1	PDPU PDS0	ST	CMOS	General purpose I/O. Register enabled pull-up
	STCK1	PDS0 IFS0	ST	—	STM1 clock input
	RX1	PDS0 IFS3	ST	—	UART1 RX serial data input
	AN9	PDS0	AN	—	12-bit A/D Converter external analog input
PD2/PTP2I/PTP2/TX1/ AN10	PD2	PDPU PDS0	ST	CMOS	General purpose I/O. Register enabled pull-up
	PTP2I	PDS0 IFS1	ST	—	PTM2 capture input
	PTP2	PDS0	—	CMOS	PTM2 output
	TX1	PDS0	—	CMOS	UART1 TX serial data output
	AN10	PDS0	AN	—	12-bit A/D Converter external analog input
PD3/PTCK2/AN11	PD3	PDPU PDS0	ST	CMOS	General purpose I/O. Register enabled pull-up
	PTCK2	PDS0 IFS0	ST	—	PTM2 clock input
	AN11	PDS0	AN	—	12-bit A/D Converter external analog input
PD4/PTP3I/PTP3/RX0/C1-	PD4	PDPU PDS1	ST	CMOS	General purpose I/O. Register enabled pull-up
	PTP3I	PDS1 IFS1	ST	—	PTM3 capture input
	PTP3	PDS1	—	CMOS	PTM3 output
	RX0	PDS1 IFS3	ST	—	UART0 RX serial data input
	C1-	PDS1	AN	—	Comparator 1 negative input

Pin Name	Function	OPT	I/T	O/T	Description
PD5/PTCK3/TX0/C1+	PD5	PDP PDS1	ST	CMOS	General purpose I/O. Register enabled pull-up
	PTCK3	PDS1 IFS0	ST	—	PTM3 clock input
	TX0	PDS1	—	CMOS	UART0 TX serial data output
	C1+	PDS1	AN	—	Comparator 1 positive input
PE1/STP0I/STP0	PE1	PEPU PES0	ST	CMOS	General purpose I/O. Register enabled pull-up
	STP0I	PES0 IFS1	ST	—	STM0 capture input
	STP0	PES0	—	CMOS	STM0 output
PE2/PTCK1	PE2	PEPU PES0	ST	CMOS	General purpose I/O. Register enabled pull-up
	PTCK1	PES0 IFS0	ST	—	PTM1 clock input
PE3/PTP1I/PTP1	PE3	PEPU PES0	ST	CMOS	General purpose I/O. Register enabled pull-up
	PTP1I	PES0 IFS1	ST	—	PTM1 capture input
	PTP1	PES0	—	CMOS	PTM1 output
PE4/VDDIO	PE4	PEPU PES1	ST	CMOS	General purpose I/O. Register enabled pull-up
	VDDIO	PES1 PMPS	PWR	—	PE1~PE3 pin power
PF0/SCS/SCOM0	PF0	PFPU PFS0	ST	CMOS	General purpose I/O. Register enabled pull-up
	SCS	PFS0 IFS2	ST	CMOS	SIM SPI slave select
	SCOM0	PFS0	—	CMOS	Software LCD COM output
PF1/SDO/SCOM1	PF1	PFPU PFS0	ST	CMOS	General purpose I/O. Register enabled pull-up
	SDO	PFS0	—	CMOS	SIM SPI data output
	SCOM1	PFS0	—	CMOS	Software LCD COM output
PF2/SDI/SDA/SCOM2	PF2	PFPU PFS0	ST	CMOS	General purpose I/O. Register enabled pull-up
	SDI	PFS0 IFS2	ST	—	SIM SPI serial data input
	SDA	PFS0 IFS2	ST	NMOS	SIM I ² C data line
	SCOM2	PFS0	—	CMOS	Software LCD COM output
PF3/SCK/SCL/SCOM3	PF3	PFPU PFS0	ST	CMOS	General purpose I/O. Register enabled pull-up
	SCK	PFS0 IFS2	ST	CMOS	SIM SPI serial clock
	SCL	PFS0 IFS2	ST	NMOS	SIM I ² C clock line
	SCOM3	PFS0	—	CMOS	Software LCD COM output
PF4/PTCK0/XT2	PF4	PFPU PFS1	ST	CMOS	General purpose I/O. Register enabled pull-up
	PTCK0	PFS1 IFS0	ST	—	PTM0 clock input
	XT2	PFS1	—	LXT	LXT oscillator pin

Pin Name	Function	OPT	I/T	O/T	Description
PF5/PTP0I/PTP0/XT1	PF5	PFFPU PFS1	ST	CMOS	General purpose I/O. Register enabled pull-up
	PTP0I	PFS1 IFS1	ST	—	PTM0 capture input
	PTP0	PFS1	—	CMOS	PTM0 output
	XT1	PFS1	LXT	—	LXT oscillator pin
VDD	VDD	—	PWR	—	Positive power supply
AVDD	AVDD	—	PWR	—	Analog positive power supply, ground
VSS	VSS	—	PWR	—	Negative power supply
AVSS	AVSS	—	PWR	—	Analog negative power supply, ground
AN0_24	AN0_24	—	AN	—	24-bit A/D Converter external input channel
AN1_24	AN1_24	—	AN	—	24-bit A/D Converter external input channel
AN2_24	AN2_24	—	AN	—	24-bit A/D Converter external input channel
AN3_24	AN3_24	—	AN	—	24-bit A/D Converter external input channel
VCM	VCM	—	—	AN	24-bit A/D Converter internal Common mode voltage output
AVDD24/VREFP	AVDD24	—	PWR	—	Analog positive power supply
	VREFP	—	AN	—	Positive reference input voltage
AVSS24/VREFN	AVSS24	—	PWR	—	Analog negative power supply
	VREFN	—	AN	—	Negative reference input voltage
DRDYB	DRDYB	—	—	NMOS	Data Ready: Indicates valid data by going low
SDA_24	SDA_24	—	ST	NMOS	I ² C data line
SCL_24	SCL_24	—	ST	—	I ² C clock line
VDD24	VDD24	—	PWR	—	Digital positive power supply
VSS24	VSS24	—	PWR	—	Digital negative power supply

Legend: I/T: Input type

OPT: Optional by register option

CMOS: CMOS output

AN: Analog signal

LXT: Low frequency crystal oscillator

O/T: Output type

ST: Schmitt Trigger input

NMOS: NMOS output

PWR: Power

HXT: High frequency crystal oscillator

Absolute Maximum Ratings

Supply Voltage	V _{SS} -0.3V to 6.0V
Input Voltage	V _{SS} -0.3V to V _{DD} +0.3V
Storage Temperature.....	-60°C to 150°C
Operating Temperature.....	-40°C to 85°C
I _{OL} Total	80mA
I _{OH} Total	-80mA
Total Power Dissipation	500mW

Note: These are stress ratings only. Stresses exceeding the range specified under “Absolute Maximum Ratings” may cause substantial damage to the device. Functional operation of this device at other conditions beyond those listed in the specification is not implied and prolonged exposure to extreme conditions may affect device reliability.

D.C. Characteristics

For data in the following tables, note that factors such as oscillator type, operating voltage, operating frequency, pin load conditions, temperature and program instruction type, etc., can all exert an influence on the measured values.

Operating Voltage Characteristics

Ta=-40°C~85°C

Symbol	Parameter	Test Conditions	Min.	Typ.	Max.	Unit
V _{DD}	Operating Voltage – HXT	f _{sys} =8MHz	1.8	—	5.5	V
		f _{sys} =12MHz	2.7	—	5.5	
		f _{sys} =16MHz	3.3	—	5.5	
	Operating Voltage – HIRC	f _{sys} =8MHz	1.8	—	5.5	
		f _{sys} =12MHz	2.7	—	5.5	
		f _{sys} =16MHz	3.3	—	5.5	
Operating Voltage – LXT	f _{sys} =32768Hz	1.8	—	5.5		
Operating Voltage – LIRC	f _{sys} =32kHz	1.8	—	5.5		

Operating Current Characteristics

Ta=25°C

Symbol	Operating Mode	Test Conditions		Min.	Typ.	Max.	Unit
		V _{DD}	Conditions				
I _{DD}	SLOW Mode – LIRC	1.8V	f _{sys} =32kHz	—	12	24	μA
		3V		—	15	30	
		5V		—	30	50	
	SLOW Mode – LXT	1.8V	f _{sys} =32768Hz	—	12	24	μA
		3V		—	15	30	
		5V		—	30	50	
	FAST Mode – HIRC	1.8V	f _{sys} =8MHz	—	0.3	1.0	mA
		3V		—	0.6	1.2	
		5V		—	1.2	2.4	
		2.7V	f _{sys} =12MHz	—	1.0	1.4	
		3V		—	1.2	1.8	
		5V		—	1.8	3.6	
		3.3V		f _{sys} =16MHz	—	2.0	
	5V	—	2.2		4.5		
	FAST Mode – HXT	1.8V	f _{sys} =8MHz	—	0.3	1.0	
		3V		—	0.6	1.2	
		5V		—	1.2	2.4	
		2.7V	f _{sys} =12MHz	—	1.0	1.4	
3V		—		1.2	1.8		
5V		—		1.8	3.6		
3.3V		f _{sys} =16MHz		—	2.0	4.0	
5V	—		2.2	4.5			

Note: When using the characteristic table data, the following notes should be taken into consideration:

1. Any digital inputs are setup in a non-floating condition.
2. All measurements are taken under conditions of no load and with all peripherals in an off state.
3. There are no DC current paths.
4. All Operating Current values are measured using a continuous NOP instruction program loop.

Standby Current Characteristics

Ta=25°C, unless otherwise specify

Symbol	Standby Mode	Test Conditions		Min.	Typ.	Max.	Max. @85°C	Unit
		V _{DD}	Conditions					
I _{STB}	SLEEP Mode	1.8V	WDT off	—	0.5	0.8	4.5	μA
		3V		—	0.6	0.9	5.0	
		5V		—	0.7	2.0	7.0	
		1.8V	WDT on	—	1.5	3.0	5.0	
		3V		—	1.8	3.6	6.0	
		5V		—	3	5	10	
	IDLE0 Mode – LIRC	1.8V	f _{SUB} on	—	2.4	4.0	8.0	μA
		3V		—	3	5	9	
		5V		—	5	10	11	
	IDLE0 Mode – LXT	1.8V	f _{SUB} on	—	2.4	4.0	8.0	μA
		3V		—	3	5	9	
		5V		—	5	10	11	
	IDLE1 Mode – HIRC	1.8V	f _{SUB} on, f _{SYS} =8MHz	—	288	400	480	μA
		3V		—	360	500	600	
		5V		—	850	1000	1200	
		2.7V	f _{SUB} on, f _{SYS} =12MHz	—	550	700	800	
		3V		—	650	800	900	
		5V		—	1800	2000	2200	
	IDLE1 Mode – HIRC	3.3V	f _{SUB} on, f _{SYS} =16MHz	—	1.8	3.6	4.4	mA
		5V		—	2.0	4.0	4.8	
	IDLE1 Mode – HXT	1.8V	f _{SUB} on, f _{SYS} =8MHz	—	288	400	480	μA
		3V		—	360	500	600	
		5V		—	850	1000	1200	
		2.7V	f _{SUB} on, f _{SYS} =12MHz	—	550	700	800	
3V		—		650	800	900		
5V		—		1800	2000	2200		
IDLE1 Mode – HXT		3.3V	f _{SUB} on, f _{SYS} =16MHz	—	1.8	3.6	4.4	
		5V		—	2.0	4.0	4.8	

Note: When using the characteristic table data, the following notes should be taken into consideration:

1. Any digital inputs are setup in a non-floating condition.
2. All measurements are taken under conditions of no load and with all peripherals in an off state.
3. There are no DC current paths.
4. All Standby Current values are taken after a HALT instruction execution thus stopping all instruction execution.

A.C. Characteristics

For data in the following tables, note that factors such as oscillator type, operating voltage, operating frequency and temperature etc., can all exert an influence on the measured values.

High Speed Internal Oscillator – HIRC – Frequency Accuracy

During the program writing operation the writer will trim the HIRC oscillator at a user selected HIRC frequency and user selected voltage of either 3V or 5V.

Symbol	Parameter	Test Conditions		Min	Typ	Max	Unit
		V _{DD}	Temp.				
f _{HIRC}	8MHz Writer Trimmed HIRC Frequency	3V/5V	25°C	-1%	8	+1%	MHz
			-40°C~85°C	-2%	8	+2%	
	12MHz Writer Trimmed HIRC Frequency	1.8V~5.5V	25°C	-5%	8	+5%	MHz
			-40°C~85°C	-10%	8	+10%	
	12MHz Writer Trimmed HIRC Frequency	3V/5V	25°C	-1%	12	+1%	MHz
			-40°C~85°C	-2%	12	+2%	
16MHz Writer Trimmed HIRC Frequency	2.7V~5.5V	25°C	-2.5%	12	+2.5%	MHz	
		-40°C~85°C	-3%	12	+3%		
16MHz Writer Trimmed HIRC Frequency	5V	25°C	-1%	16	+1%	MHz	
		-40°C~85°C	-2%	16	+2%		
		3.3V~5.5V	25°C	-2.5%	16	+2.5%	
			-40°C~85°C	-3%	16	+3%	

Note: 1. The 3V/5V values for V_{DD} are provided as these are the two selectable fixed voltages at which the HIRC frequency is trimmed by the writer.

2. The row below the 3V/5V trim voltage row is provided to show the values for the full V_{DD} range operating voltage. It is recommended that the trim voltage is fixed at 3V for application voltage ranges from 1.8V to 3.6V and fixed at 5V for application voltage ranges from 3.3V to 5.5V.

3. The minimum and maximum tolerance values provided in the table are only for the frequency at which the writer trims the HIRC oscillator. After trimming at this chosen specific frequency any change in HIRC oscillator frequency using the oscillator register control bits by the application program will give a frequency tolerance to within ±20%.

Low Speed Internal Oscillator Characteristics – LIRC

Symbol	Parameter	Test Conditions		Min.	Typ.	Max.	Unit
		V _{DD}	Temp.				
f _{LIRC}	LIRC Frequency	3V	25°C	-2%	32	+2%	kHz
		2.2V~5.5V	-40°C~85°C	-10%	32	+10%	
		1.8V~5.5V	-40°C~85°C	-15%	32	+15%	
t _{START}	LIRC Start Up Time	—	25°C	—	—	100	µs

Low Speed Crystal Oscillator Characteristics – LXT

T_a=25°C, unless otherwise specify

Symbol	Parameter	Test Conditions		Min.	Typ.	Max.	Unit
		V _{DD}	Conditions				
f _{LXT}	LXT Frequency	1.8V~5.5V	—	—	32768	—	Hz
t _{START}	LXT Start Up Time	3V	—	—	—	1000	ms
		5V	—	—	—	1000	
Duty Cycle	Duty Cycle	—	—	40	—	60	%
R _{NEG}	Negative Resistance	1.8V	—	3×ESR	—	—	Ω

Note: C₁, C₂ and R_p are external components, C₁=C₂=10pF, R_p=10MΩ, C_L=7pF, ESR=30kΩ.

Operating Frequency Characteristic Curves

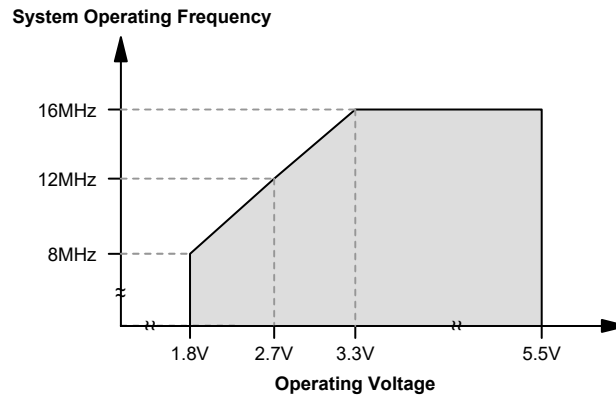

System Start Up Time Characteristics

Ta=-40°C~85°C

Symbol	Parameter	Test Conditions		Min.	Typ.	Max.	Unit
		V _{DD}	Conditions				
t _{SST}	System Start-up Time Wake-up from condition where f _{sys} is off	—	f _{sys} =f _H ~f _H /64, f _H =f _{HXT}	—	128	—	t _{HXT}
		—	f _{sys} =f _H ~f _H /64, f _H =f _{HIRC}	—	16	—	t _{HIRC}
		—	f _{sys} =f _{SUB} =f _{LXT}	—	1024	—	t _{LXT}
		—	f _{sys} =f _{SUB} =f _{LIRC}	—	2	—	t _{LIRC}
	System Start-up Time Wake-up from condition where f _{sys} is on	—	f _{sys} =f _H ~f _H /64, f _H =f _{HXT} OR f _{HIRC}	—	2	—	t _H
		—	f _{sys} =f _{SUB} =f _{LXT} OR f _{LIRC}	—	2	—	t _{SUB}
System Speed Switch Time FAST to SLOW Mode or SLOW to FAST Mode		—	f _{HXT} switches from off → on	—	1024	—	t _{HXT}
		—	f _{HIRC} switches from off → on	—	16	—	t _{HIRC}
		—	f _{LXT} switches from off → on	—	1024	—	t _{LXT}
t _{RSTD}	System Reset Delay Time Reset Source from Power-on Reset or LVR Hardware Reset	—	RR _{POR} =5V/ms	42	48	54	ms
	System Reset Delay Time LVRC/WDT/RSTC Software Reset	—	—	—	—	—	—
	System Reset Delay Time (Reset Source from WDT Overflow or RES pin reset)	—	—	14	16	18	ms

Note: 1. For the System Start-up time values, whether f_{sys} is on or off depends upon the mode type and the chosen f_{sys} system oscillator. Details are provided in the System Operating Modes section.

2. The time units, shown by the symbols t_{HXT}, t_{HIRC} etc., are the inverse of the corresponding frequency values as provided in the frequency tables. For example t_{HIRC}=1/f_{HIRC}, t_{sys}=1/f_{sys} etc.

3. If the LIRC is used as the system clock and if it is off when in the SLEEP Mode, then an additional LIRC start up time, t_{START}, as provided in the LIRC frequency table, must be added to the t_{SST} time in the table above.

4. The System Speed Switch Time is effectively the time taken for the newly activated oscillator to start up.

Input/Output Characteristics

Input/Output (without Multi-power) D.C Characteristics

Ta=25°C, unless otherwise specify

Symbol	Parameter	Test Conditions		Min.	Typ.	Max.	Unit
		V _{DD}	Conditions				
V _{IL}	Input Low Voltage for I/O Ports except PE1~PE3 and $\overline{\text{RES}}$ Pins	5V	—	0	—	1.5	V
		—	—	0	—	0.2V _{DD}	
	—	V _{DD} ≥2.7	0	—	0.4V _{DD}		
	—	1.8≤V _{DD} <2.7	0	—	0.3V _{DD}		
V _{IH}	Input High Voltage for I/O Ports except PE1~PE3 and $\overline{\text{RES}}$ Pins	5V	—	3.5	—	5.0	V
		—	—	0.8V _{DD}	—	V _{DD}	
	—	—	0.9V _{DD}	—	V _{DD}	V	
I _{OL}	Sink Current for I/O Ports except PE1~PE3 Pins	3V	V _{OL} =0.1V _{DD}	16	32	—	mA
		5V		32	65	—	
I _{OH}	Source Current for I/O Ports except PE1~PE3 Pins	3V	V _{OH} =0.9V _{DD} , SLEDCn[m+1:m]=00, (n=0~3; m=0, 2, 4, 6)	-0.7	-1.5	—	mA
		5V		-1.5	-2.9	—	
		3V	V _{OH} =0.9V _{DD} , SLEDCn[m+1:m]=01, (n=0~3; m=0, 2, 4, 6)	-1.3	-2.5	—	
		5V		-2.5	-5.1	—	
		3V	V _{OH} =0.9V _{DD} , SLEDCn[m+1:m]=10, (n=0~3; m=0, 2, 4, 6)	-1.8	-3.6	—	
		5V		-3.6	-7.3	—	
		3V	V _{OH} =0.9V _{DD} , SLEDCn[m+1:m]=11, (n=0~3; m=0, 2, 4, 6)	-4	-8	—	
		5V		-8	-16	—	
R _{PH}	Pull-high Resistance for I/O Ports except PE1~PE3 Pins ^(Note)	3V	LVPU=0	20	60	100	kΩ
		5V		PxPU=FFH (Px: PA~PF)	10	30	
		3V	LVPU=1	6.67	15.00	23.00	
		5V		PxPU=FFH (Px: PA~PF)	3.5	7.5	
I _{LEAK}	Input Leakage Current for I/O Ports except PE1~PE3 Pins	3V	V _{IN} =V _{DD} or V _{IN} =V _{SS}	—	—	±1	μA
		5V	V _{IN} =V _{DD} or V _{IN} =V _{SS}	—	—	±1	μA
t _{TCK}	TM Clock Input Pin Minimum Pulse Width	—	—	0.3	—	—	μs
t _{TPI}	TM Capture Input Pin Minimum Pulse Width	—	—	0.3	—	—	μs
t _{INT}	External Interrupt Minimum Pulse Width	—	—	10	—	—	μs
t _{SRESET}	Minimum Software Reset Width to Reset	—	—	45	90	120	μs
t _{RES}	External reset minimum low pulse width	—	—	10	—	—	μs

Note: The R_{PH} internal pull high resistance value is calculated by connecting to ground and enabling the input pin with a pull-up resistor and then measuring the input current at the specified supply voltage level. Dividing the voltage by this measured current provides the R_{PH} value.

Input/Output (with Multi-power) D.C Characteristics

Ta=25°C, unless otherwise specify

Symbol	Parameter	Test Conditions		Min.	Typ.	Max.	Unit
		V _{DD}	Conditions				
V _{DD}	V _{DD} Power Supply for PE1~PE3 Pins	—	—	1.8	5.0	5.5	V
V _{DDIO}	V _{DDIO} Power Supply for PE1~PE3 Pins	—	—	1.8	—	V _{DD}	V
V _{IL}	Input Low Voltage for PE1~PE3 Pins	5V	Pin power=V _{DD} or V _{DDIO} V _{DDIO} =V _{DD}	0	—	1.5	V
		—	Pin power=V _{DD} or V _{DDIO}	0	—	0.2 (V _{DD} /V _{DDIO})	
V _{IH}	Input High Voltage for PE1~PE3 Pins	5V	Pin power=V _{DD} or V _{DDIO} V _{DDIO} =V _{DD}	3.5	—	5.0	V
		—	Pin power=V _{DD} or V _{DDIO}	0.8 (V _{DD} /V _{DDIO})	—	V _{DD} /V _{DDIO}	
I _{OL}	Sink Current for PE1~PE3 Pins	3V	V _{OL} =0.1(V _{DD} /V _{DDIO}), V _{DDIO} =V _{DD}	16	32	—	mA
		5V	V _{OL} =0.1(V _{DD} /V _{DDIO}), V _{DDIO} =V _{DD} V _{OL} =0.1V _{DDIO} , V _{DDIO} =3V	32	65	—	
I _{OH}	Source Current for PE1~PE3 Pins	3V	V _{OH} =0.9(V _{DD} /V _{DDIO}), V _{DDIO} =V _{DD} SLEDC2[1:0]=00B	-0.7	-1.5	—	mA
		5V	V _{OH} =0.9(V _{DD} /V _{DDIO}), V _{DDIO} =V _{DD} SLEDC2[1:0]=00B V _{OH} =0.9V _{DDIO} , V _{DDIO} =3V SLEDC2[1:0]=00B	-1.5	-2.9	—	
		3V	V _{OH} =0.9(V _{DD} /V _{DDIO}), V _{DDIO} =V _{DD} SLEDC2[1:0]=01B	-1.3	-2.5	—	mA
		5V	V _{OH} =0.9(V _{DD} /V _{DDIO}), V _{DDIO} =V _{DD} SLEDC2[1:0]=01B V _{OH} =0.9V _{DDIO} , V _{DDIO} =3V SLEDC2[1:0]=01B	-2.5	-5.1	—	
		3V	V _{OH} =0.9(V _{DD} /V _{DDIO}), V _{DDIO} =V _{DD} SLEDC2[1:0]=10B	-1.8	-3.6	—	mA
		5V	V _{OH} =0.9(V _{DD} /V _{DDIO}), V _{DDIO} =V _{DD} SLEDC2[1:0]=10B V _{OH} =0.9V _{DDIO} , V _{DDIO} =3V SLEDC2[1:0]=10B	-3.6	-7.3	—	
		3V	V _{OH} =0.9(V _{DD} /V _{DDIO}), V _{DDIO} =V _{DD} SLEDC2[1:0]=11B	-4	-8	—	mA
		5V	V _{OH} =0.9(V _{DD} /V _{DDIO}), V _{DDIO} =V _{DD} SLEDC2[1:0]=11B V _{OH} =0.9V _{DDIO} , V _{DDIO} =3V SLEDC2[1:0]=11B	-8	-16	—	
				-2.5	-5.0	—	

Symbol	Parameter	Test Conditions		Min.	Typ.	Max.	Unit
		V _{DD}	Conditions				
R _{PH}	Pull-high Resistance for PE1~PE3 Pins ^(Note)	3V	V _{DDIO} =V _{DD} , LVPU=0 PEPU=FFH	20	60	100	kΩ
		5V	V _{DDIO} =V _{DD} , LVPU=0 PEPU=FFH	10	30	50	
			V _{DDIO} =3V, LVPU=0 PEPU=FFH	36	110	45	
		3V	V _{DDIO} =V _{DD} , LVPU=1 PEPU=FFH	6.67	15.00	23.00	
		5V	V _{DDIO} =V _{DD} , LVPU=1 PEPU=FFH	3.5	7.5	12.0	
			V _{DDIO} =3V, LVPU=1 PEPU=FFH	9.0	27.5	45.0	
I _{LEAK}	Input Leakage Current for PE1~PE3 Pins	5V	V _{IN} =V _{SS} or V _{IN} =V _{DD} or V _{DDIO}	—	—	±1	μA

Note: The R_{PH} internal pull high resistance value is calculated by connecting to ground and enabling the input pin with a pull-up resistor and then measuring the input current at the specified supply voltage level. Dividing the voltage by this measured current provides the R_{PH} value.

12-Bit A/D Converter Electrical Characteristics

T_a=25°C, unless otherwise specify

Symbol	Parameter	Test Conditions		Min.	Typ.	Max.	Unit	
		V _{DD}	Conditions					
V _{DD}	Operating Voltage	—	—	1.8	—	5.5	V	
V _{ADI}	Input Voltage	—	—	0	—	V _{REF}	V	
V _{REF}	Reference Voltage	—	—	1.8	—	V _{DD}	V	
DNL	Differential Non-linearity	1.8V	SAINS[3:0]=0000B, SAVRS[1:0]=01B, V _{REF} =V _{DD} , t _{ADCK} =2.0μs	-3	—	3	LSB	
		2V	SAINS[3:0]=0000B, SAVRS[1:0]=01B, V _{REF} =V _{DD} , t _{ADCK} =0.5μs					
			3V					SAINS[3:0]=0000B, SAVRS[1:0]=01B, V _{REF} =V _{DD} , t _{ADCK} =0.5μs
			5V					SAINS[3:0]=0000B, SAVRS[1:0]=01B, V _{REF} =V _{DD} , t _{ADCK} =10μs
		3V	SAINS[3:0]=0000B, SAVRS[1:0]=01B, V _{REF} =V _{DD} , t _{ADCK} =10μs					
			1.8V					SAINS[3:0]=0000B, SAVRS[1:0]=01B, V _{REF} =V _{DD} , t _{ADCK} =2.0μs
5V	SAINS[3:0]=0000B, SAVRS[1:0]=01B, V _{REF} =V _{DD} , t _{ADCK} =2.0μs							
INL	Integral Non-linearity	1.8V	SAINS[3:0]=0000B, SAVRS[1:0]=01B, V _{REF} =V _{DD} , t _{ADCK} =2.0μs	-4	—	4	LSB	
		2V	SAINS[3:0]=0000B, SAVRS[1:0]=01B, V _{REF} =V _{DD} , t _{ADCK} =0.5μs					
			3V					SAINS[3:0]=0000B, SAVRS[1:0]=01B, V _{REF} =V _{DD} , t _{ADCK} =0.5μs
			5V					SAINS[3:0]=0000B, SAVRS[1:0]=01B, V _{REF} =V _{DD} , t _{ADCK} =10μs
		3V	SAINS[3:0]=0000B, SAVRS[1:0]=01B, V _{REF} =V _{DD} , t _{ADCK} =10μs					
			1.8V					SAINS[3:0]=0000B, SAVRS[1:0]=01B, V _{REF} =V _{DD} , t _{ADCK} =2.0μs
5V	SAINS[3:0]=0000B, SAVRS[1:0]=01B, V _{REF} =V _{DD} , t _{ADCK} =2.0μs							
I _{ADC}	Additional Current Consumption for A/D Converter Enable	1.8V	No load, t _{ADCK} =2.0μs	—	280	400	μA	
		3V	No load, t _{ADCK} =0.5μs	—	450	600	μA	
		5V	No load, t _{ADCK} =0.5μs	—	850	1000	μA	
t _{ADCK}	Clock Period	—	1.8V≤V _{DD} <2.0V	2.0	—	10	μs	
			2.0V≤V _{DD} ≤5.5V	0.5	—	10	μs	

Symbol	Parameter	Test Conditions		Min.	Typ.	Max.	Unit
		V _{DD}	Conditions				
t _{ON2ST}	A/D Converter On-to-Start Time	—	—	4	—	—	μs
t _{ADS}	Sampling Time	—	—	—	4	—	t _{ADCK}
t _{ADC}	Conversion Time (Including A/D Converter Sample and Hold Time)	—	—	—	16	—	t _{ADCK}
I _{PGA}	Additional Current for PGA Enable	2.2V	No load, PGAIS=1, PGAGS[1:0]=01	—	250	500	μA
		3V		—	300	600	
		5V		—	400	700	
V _{OR}	PGA Maximum Output Voltage Range	2.2V	—	V _{SS} +0.1	—	V _{DD} -0.1	V
		3V					
		5V					
V _{VR}	Fix Voltage Output of PGA	2.2V ~5.5V	Ta=-40°C~85°C V _{RI} =V _{BGREF} (PGAIS=1)	-1%	2	+1%	V
		3.2V ~5.5V		-1%	3	+1%	
		4.2V ~5.5V		-1%	4	+1%	
V _{IR}	PGA Input Voltage Range	3V	Gain=1, PGAIS=0 Relative gain Gain error < ±5%	V _{SS} +0.1	—	V _{DD} -1.4	V
		5V		V _{SS} +0.1	—	V _{DD} -1.4	V

Internal Reference Voltage Electrical Characteristics

Ta=-40°C~85°C, unless otherwise specify

Symbol	Parameter	Test Conditions		Min.	Typ.	Max.	Unit
		V _{DD}	Conditions				
V _{DD}	Operating Voltage	—	—	1.8	—	5.5	V
V _{BGREF}	Bandgap Reference Voltage	5V	Ta=25°C	-1%	1.2	+1%	V
		1.8V~2.1V	Ta=-40°C~85°C	-10%	1.2	+10%	V
		2.2V~5.5V	Ta=-40°C~85°C	-2%	1.2	+2%	V
I _{BGREF}	Operating Current	5.5V	—	—	25	40	μA
PSRR	Power Supply Rejection Ratio	—	Ta=25°C, V _{RI} =1V _{P-P} , f _{RI} =100Hz	75	—	—	dB
En	Output Noise	—	Ta=25°C, no load current, f=0.1Hz~10Hz	—	300	—	μV _{RMS}
I _{SD}	Shutdown Current	—	V _{BGREN} =0	—	—	0.1	μA
t _{START}	Startup Time	1.8V~5.5V	Ta=25°C	—	—	400	μs

Note: 1. All the above parameters are measured under conditions of no load condition unless otherwise described.

2. A 0.1μF ceramic capacitor should be connected between V_{DD} and GND.

3. The V_{BGREF} voltage is used as the A/D converter PGA input.

Comparator Electrical Characteristics

Ta=-40°C~85°C, unless otherwise specify

Symbol	Parameter	Test Condition		Min.	Typ.	Max.	Unit
		V _{DD}	Conditions				
V _{DD}	Comparator Operating Voltage	—	—	1.8	—	5.5	V
I _{CMP}	Additional Current for Comparator enable	3V	CNVTn[1:0]=00B	—	1	5	μA
		5V		—	1	5	
		3V	CNVTn[1:0]=01B	—	—	30	
		5V		—	14	30	
		3V	CNVTn[1:0]=10B	—	—	65	
		5V		—	36	65	
		3V	CNVTn[1:0]=11B	—	—	110	
		5V		—	58	110	
V _{OS}	Input Offset Voltage	3V	Without calibration (CnOF[4:0]=10000B)	-10	—	+10	mV
		5V		-10	—	+10	
		3V	With calibration (CNVTn[1:0]=00B)	-2	—	+2	
		5V		-2	—	+2	
V _{HYS}	Hysteresis Width	3V	CNVTn[1:0]=00B	10	—	30	mV
		5V		10	24	30	mV
V _{CM}	Common Mode Voltage Range	1.8V	CNVTn[1:0]=00, 01, 10, 11B	0	—	V _{DD} -1.0	V
		3V					
		5V					
A _{OL}	Comparator Open Loop Gain	3V	CNVTn[1:0]=00B	60	—	—	dB
		5V		60	80	—	
t _{RP}	Comparator Response Time	3V	With 100mV overdrive ⁽¹⁾ CNVTn[1:0]=00B	—	20	40	μs
		5V		—	20	40	
		3V	With 100mV overdrive ⁽¹⁾ CNVTn[1:0]=01B	—	1.2	3.0	
		5V		—	1.2	3.0	
		3V	With 100mV overdrive ⁽¹⁾ CNVTn[1:0]=10B	—	0.5	1.5	
		5V		—	0.5	1.5	
		3V	With 100mV overdrive ⁽¹⁾ CNVTn[1:0]=11B	—	0.3	1.0	
		5V		—	0.3	1.0	

Note: 1. Load Condition: C_{LOAD}=50pF

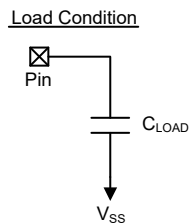

2. All measurements are under Cn+input voltage=(V_{CMMIN}+V_{CMMAX})/2 and remain constant.

Memory Electrical Characteristics

Ta=-40°C~85°C, unless otherwise specify

Symbol	Parameter	Test Conditions		Min.	Typ.	Max.	Unit
		V _{DD}	Conditions				
V _{RW}	V _{DD} for Read/Write	—	—	V _{DDmin}	—	V _{DDmax}	V
Flash Program Memory							
t _{FWR}	Write Time	—	FWERTS bit=0	—	2.2	2.7	ms
		—	FWERTS bit=1	—	3.0	3.6	ms
t _{FER}	Erase Time	—	FWERTS bit=0	—	3.2	3.9	ms
		—	FWERTS bit=1	—	3.7	4.5	ms
E _P	Cell Endurance	—	—	10K	—	—	E/W
t _{RETD}	ROM Data Retention Time	—	Ta=25°C	—	40	—	Year
t _{ACTV}	ROM Activation Time – Wake-up from Power Down Mode ^(Note)	—	—	32	—	64	μs
Data EEPROM Memory							
t _{EEWR}	Write Time (byte mode)	—	EWERTS bit=0	—	5.4	6.6	ms
		—	EWERTS bit=1	—	6.7	8.1	ms
	Write Time (page mode)	—	EWERTS bit=0	—	2.2	2.7	ms
		—	EWERTS bit=1	—	3.0	3.6	ms
t _{EEER}	Erase Time	—	EWERTS bit=0	—	3.2	3.9	ms
		—	EWERTS bit=1	—	3.7	4.5	ms
E _P	Cell Endurance	—	—	100K	—	—	E/W
t _{RETD}	ROM Data Retention Time	—	Ta=25°C	—	40	—	Year
RAM Data Memory							
V _{DR}	RAM Data Retention Voltage	—	—	1.0	—	—	V

Note: 1. The ROM activation time t_{ACTV} should be added when calculating the total system start-up time of a wake-up from the power down mode.

2. “E/W” means Erase/Write times.

LVD/LVR Electrical Characteristics

Ta=25°C, unless otherwise specify

Symbol	Parameter	Test Conditions		Min.	Typ.	Max.	Unit
		V _{DD}	Conditions				
V _{LVR}	Low Voltage Reset Voltage	—	LVR enable, voltage select 1.7V	-5%	1.7	+5%	V
			LVR enable, voltage select 1.9V		1.9		
			LVR enable, voltage select 2.55V	-3%	2.55	+3%	
			LVR enable, voltage select 3.15V		3.15		
			LVR enable, voltage select 3.8V		3.8		
V _{LVD}	Low Voltage Detection Voltage	—	LVD enable, voltage select 1.8V	-5%	1.8	+5%	V
			LVD enable, voltage select 2.0V		2.0		
			LVD enable, voltage select 2.4V		2.4		
			LVD enable, voltage select 2.7V		2.7		
			LVD enable, voltage select 3.0V		3.0		
			LVD enable, voltage select 3.3V		3.3		
			LVD enable, voltage select 3.6V		3.6		
LVD enable, voltage select 4.0V	4.0						
I _{LVR/LVD}	Operating Current	3V	LVD enable, LVR enable,	—	—	15	μA
		5V	V _{LVR} =1.9V, V _{LVD} =2V	—	10	15	

Symbol	Parameter	Test Conditions		Min.	Typ.	Max.	Unit
		V _{DD}	Conditions				
t _{LVDs}	LVDO Stable Time	—	For LVR enable, LVD off → on Ta=-40°C~85°C	—	—	18	μs
		—	For LVR disable, LVD off → on Ta=-40°C~85°C	—	—	20	μs
t _{LVR}	Minimum Low Voltage Width to Reset	—	—	120	240	480	μs
t _{LVD}	Minimum Low Voltage Width to Interrupt	—	—	60	120	240	μs
I _{LVR}	Additional Current for LVR Enable	5V	LVD disable	—	—	15	μA
I _{LVD}	Additional Current for LVD Enable	5V	LVR disable	—	—	15	μA

LCD Electrical Characteristics

Ta=25°C

Symbol	Parameter	Test Conditions		Min.	Typ.	Max.	Unit
		V _{DD}	Conditions				
I _{BIAS}	V _{DD} /2 Bias Current for LCD	3V	ISEL[1:0]=00B	10.5	15.0	19.5	μA
		5V		17.5	25.0	32.5	
		3V	ISEL[1:0]=01B	21	30	39	
		5V		35	50	65	
		3V	ISEL[1:0]=10B	42	60	78	
		5V		70	100	130	
		3V	ISEL[1:0]=11B	82.6	118.0	153.4	
		5V		140	200	260	
V _{SCOM}	V _{DD} /2 Voltage for LCD COM Ports	2.2V~5.5V	No load	0.475V _{DD}	0.500V _{DD}	0.525V _{DD}	V

24-Bit ADC Characteristics

V_{DD24}=AV_{DD24}, Ta=25 °C, unless otherwise specify.

Symbol	Parameter	Test Conditions		Min.	Typ.	Max.	Unit
		V _{DD24}	Conditions				
AV _{DD24}	Supply Voltage for VCM, ADC, PGA	—	—	2.4	—	5.5	V
V _{OUT_VCM}	VCM Output Voltage (VCM Pin)	—	AV _{DD24} =3.3V, No load	-5%	1.25	+5%	V
TC _{VCM}	VCM Temperature Coefficient	—	Ta=-40°C~85°C, AV _{DD24} =3.3V, I _{LOAD} =10μA	—	—	0.24	mV/°C
ΔV _{LINE_VCM}	VCM Line Regulation	—	2.4V ≤ AV _{DD24} ≤ 3.3V, No load	—	—	0.4	%/V
t _{VCMS}	VCM Turn-on Stable Time	—	AV _{DD24} =3.3V, No load	—	—	10	ms
I _{OH}	Source Current for VCM Pin	—	AV _{DD24} =3.3V, ΔV _{OUT_VCM} =-2%	3	—	—	mA
I _{oL}	Sink Current for VCM Pin	—	AV _{DD24} =3.3V, ΔV _{OUT_VCM} =+2%	3	—	—	mA

Symbol	Parameter	Test Conditions		Min.	Typ.	Max.	Unit
		V _{DD24}	Conditions				
ADC & ADC Internal Reference Voltage (Sigma Delta ADC)							
I _{ADC}	Additional Current for ADC Enable	—	VCM enable, VRBUF=1 and VRBUFN=1	—	—	1120	μA
I _{ADC}	Additional Current for ADC Enable	—	VCM enable, VRBUF=0 and VRBUFN=0	—	820	970	μA
			VCM disable, VRBUF=0 and VRBUFN=0	—	500	650	μA
I _{ADSTB}	Standby Current	—	ADC off, no load	—	—	1	μA
RS _{ADC}	Resolution	—	—	—	—	24	bit
INL	Integral Non-linearity	—	AV _{DD24} =3.3V, V _{REF} =1.25V, ΔSI=±450mV, PGA Gain=1	—	±50	—	ppm
NFB	Noise Free Bits	—	V _{REF} =2.5V, Gain=32, Data rate=10Hz	—	18.0	—	Bit
			V _{REF} =2.5V, Gain=64, Data rate=10Hz	—	17.4	—	Bit
			V _{REF} =2.5V, Gain=128, Data rate=10Hz	—	16.7	—	Bit
ENOB	Effective Number of Bits	—	V _{REF} =2.5V, Gain=32, Data rate=10Hz	—	20.7	—	Bit
			V _{REF} =2.5V, Gain=64, Data rate=10Hz	—	20.1	—	Bit
			V _{REF} =2.5V, Gain=128, Data rate=10Hz	—	19.4	—	Bit
f _{ADCK}	ADC Clock Frequency	—	—	40	409.6	440	kHz
f _{ADO}	ADC Output Data Rate	—	f _{MCLK} =4.9152MHz, FLMS[2:0]=000B	5	—	640	Hz
			f _{MCLK} =4.9152MHz, FLMS[2:0]=010B	12.5	—	1600	Hz
V _{REFP}	External Reference Input Voltage	—	VREFS=1, VRBUF=0,	V _{REFN} +1	—	AV _{DD24}	V
V _{REFN}		—	VRBUFN=0	0	—	V _{REFP} -1	V
V _{REF}		—	V _{REF} =(V _{REFP} -V _{REFN})×VGS	1	—	AV _{DD24} /2	V
PGA							
V _{CM_PGA}	Common Mode Voltage Range	—	—	0.4	—	AV _{DD24} -0.95	V
ΔD _I	Differential Input Voltage Range	—	Gain=PGS×AGS, ΔD _I =DI+ - DI-	-V _{REF} /Gain	—	+V _{REF} /Gain	V
Temperature Sensor							
TCTS	Temperature Sensor Temperature Coefficient	—	Ta=-40°C~85°C, V _{REF} =1.25V, VGS[1:0]=00B (Gain=1), VRBUF=0, VRBUFN=0	—	175	—	μV/°C

Effective Number of Bits (ENOB)

$V_{REF}=2.5V, f_{ADCK}=163kHz$

Data Rate (SPS)	PGA Gain							
	1	2	4	8	16	32	64	128
5	21.5	21.2	21.1	21.1	21.0	20.9	20.4	19.6
10	21.2	21.0	21.0	20.9	20.8	20.7	20.1	19.4
20	21.1	20.7	20.7	20.6	20.5	20.3	19.7	18.9
40	20.6	20.5	20.4	20.2	20.1	19.9	19.2	18.5
80	20.2	20.1	20.0	19.9	19.8	19.5	18.8	18.0
160	19.7	19.5	19.5	19.4	19.3	19.0	18.4	17.6
320	19.1	18.9	18.9	18.8	18.7	18.5	17.9	17.1
640	18.6	18.4	18.4	18.3	18.3	18.0	17.4	16.6

$V_{REF}=2.5V, f_{ADCK}=409kHz$

Data Rate (SPS)	PGA Gain							
	1	2	4	8	16	32	64	128
12.5	21.9	21.4	21.4	21.3	21.1	20.7	19.9	19.2
25	21.6	21.1	21.1	21.0	20.9	20.4	19.6	18.8
50	21.2	20.9	20.8	20.7	20.4	19.9	19.2	18.3
100	20.8	20.5	20.4	20.3	20.0	19.5	18.8	17.9
200	20.3	19.7	19.7	19.6	19.4	18.9	18.2	17.4
400	19.3	19.0	19.0	18.9	18.8	18.4	17.8	16.9
800	18.8	18.6	18.6	18.5	18.3	17.9	17.2	16.5
1600	18.4	18.2	18.2	18.1	17.9	17.4	16.8	16.1

$V_{REF}=1.65V, f_{ADCK}=163kHz$

Data Rate (SPS)	PGA Gain							
	1	2	4	8	16	32	64	128
5	21.5	21.2	21.2	21.1	20.9	20.5	20.0	19.2
10	21.3	21.0	20.9	20.7	20.5	20.2	19.5	18.7
20	20.9	20.6	20.5	20.4	20.2	19.8	19.1	18.3
40	20.4	20.1	20.1	20.0	19.8	19.4	18.8	18.0
80	19.8	19.5	19.5	19.4	19.2	18.8	18.2	17.5
160	19.3	19.0	19.0	18.9	18.7	18.4	17.8	17.0
320	18.8	18.5	18.5	18.4	18.3	17.9	17.3	16.5
640	18.3	18.1	18.1	18.0	17.8	17.5	16.8	16.0

$V_{REF}=1.65V, f_{ADCK}=409kHz$

Data Rate (SPS)	PGA Gain							
	1	2	4	8	16	32	64	128
12.5	21.8	21.4	21.2	21.1	20.7	20.3	19.5	18.6
25	21.4	21.1	20.9	20.7	20.3	19.7	19.0	18.2
50	20.9	20.6	20.5	20.3	19.9	19.4	18.6	17.7
100	20.4	20.2	20.0	19.8	19.4	18.9	18.1	17.3
200	19.8	19.4	19.3	19.2	18.9	18.4	17.7	16.8
400	19.0	18.8	18.7	18.6	18.4	17.8	17.2	16.3
800	18.7	18.4	18.3	18.2	17.9	17.4	16.7	15.8
1600	18.2	18.0	17.9	17.7	17.3	16.7	16.2	15.4

$V_{REF}=1.2V, f_{ADCK}=163kHz$

Data Rate (SPS)	PGA Gain							
	1	2	4	8	16	32	64	128
5	20.6	20.4	20.4	20.3	20.3	20.1	19.6	18.9
10	20.5	20.3	20.3	20.2	20.0	19.9	19.2	18.4
20	20.3	19.9	19.9	19.8	19.7	19.4	18.8	18.0
40	19.8	19.5	19.5	19.4	19.2	18.9	18.3	17.5
80	19.3	19.1	19.1	19.0	18.8	18.5	17.8	17.0
160	19.0	18.8	18.7	18.6	18.3	18.0	17.4	16.5
320	18.5	18.2	18.2	18.1	17.8	17.5	16.9	16.1
640	17.9	17.7	17.7	17.6	17.3	17.0	16.4	15.6

 $V_{REF}=1.2V, f_{ADCK}=409kHz$

Data Rate (SPS)	PGA Gain							
	1	2	4	8	16	32	64	128
12.5	20.9	20.7	20.5	20.3	20.1	19.8	19.1	18.2
25	20.7	20.4	20.2	20.1	19.8	19.4	18.6	17.8
50	20.3	20.1	19.8	19.7	19.4	18.8	18.1	17.4
100	19.9	19.6	19.4	19.2	18.9	18.4	17.7	16.8
200	19.5	19.2	19.0	18.8	18.5	17.9	17.2	16.4
400	18.9	18.7	18.6	18.4	18.0	17.5	16.7	15.9
800	18.5	18.2	18.0	17.8	17.5	16.9	16.2	15.4
1600	17.9	17.6	17.5	17.3	16.9	16.4	15.7	14.9

I²C Electrical Characteristics

 $T_a=25^{\circ}C$

Symbol	Parameter	Test Conditions		Min.	Typ.	Max.	Unit
		V _{DD}	Conditions				
f _{I2C}	I ² C Standard Mode (100kHz) f _{sys} Frequency <small>(Note)</small>	—	No clock debounce	2	—	—	MHz
			2 system clock debounce	4	—	—	
			4 system clock debounce	4	—	—	
	I ² C Fast Mode (400kHz) f _{sys} Frequency <small>(Note)</small>	—	No clock debounce	4	—	—	MHz
			2 system clock debounce	8	—	—	
			4 system clock debounce	8	—	—	
f _{SCL}	SCL Clock Frequency	3V/5V	Standard mode	—	—	100	kHz
			Fast mode	—	—	400	
t _{SCL(H)}	SCL Clock High Time	3V/5V	Standard mode	3.5	—	—	μs
			Fast mode	0.9	—	—	
t _{SCL(L)}	SCL Clock Low Time	3V/5V	Standard mode	3.5	—	—	μs
			Fast mode	0.9	—	—	
t _{FALL}	SCL and SDA Fall Time	3V/5V	Standard mode	—	—	1.3	μs
			Fast mode	—	—	0.34	
t _{RISE}	SCL and SDA Rise Time	3V/5V	Standard mode	—	—	1.3	μs
			Fast mode	—	—	0.34	
t _{SU(SDA)}	SDA Data Setup Time	3V/5V	Standard mode	0.25	—	—	μs
			Fast mode	0.1	—	—	
t _{H(SDA)}	SDA Data Hold Time	3V/5V	—	0.1	—	—	μs

Symbol	Parameter	Test Conditions		Min.	Typ.	Max.	Unit
		V _{DD}	Conditions				
t _{VD(SDA)}	SDA Data Valid Time	3V/5V	—	—	—	0.6	μs
t _{SU(STA)}	Start Condition Setup Time	3V/5V	Standard mode	3.5	—	—	μs
			Fast mode	0.6	—	—	
t _{H(STA)}	Start Condition Hold Time	3V/5V	—	0.6	—	—	μs
t _{SU(STO)}	Stop Condition Setup Time	3V/5V	Standard mode	3.5	—	—	μs
			Fast mode	0.6	—	—	

Note: Using the debounce function can make the transmission more stable and reduce the probability of communication failure due to interference.

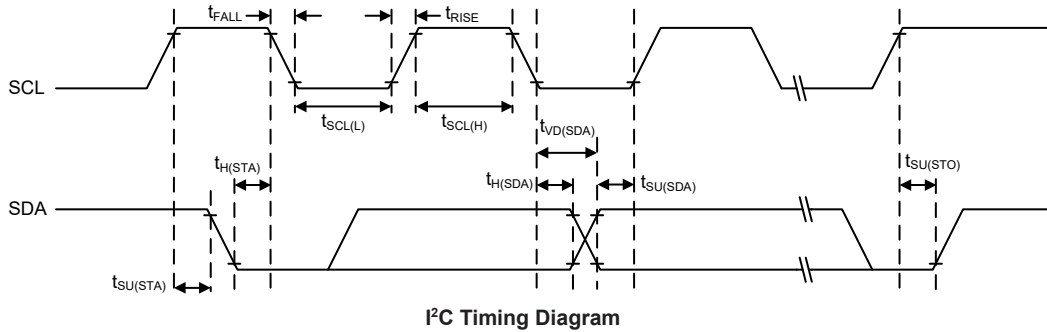

Power-on Reset Characteristics

T_a=-40°C~85°C

Symbol	Parameter	Test Conditions		Min.	Typ.	Max.	Unit
		V _{DD}	Conditions				
V _{POR}	V _{DD} Start Voltage to Ensure Power-on Reset	—	—	—	—	100	mV
RR _{POR}	V _{DD} Rising Rate to Ensure Power-on Reset	—	—	0.035	—	—	V/ms
t _{POR}	Minimum Time for V _{DD} Stays at V _{POR} to Ensure Power-on Reset	—	—	1	—	—	ms

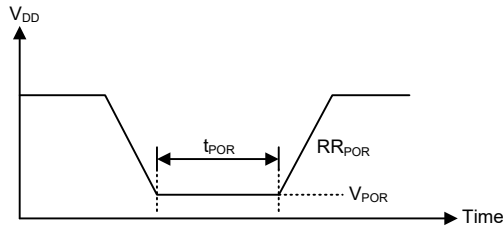

System Architecture

A key factor in the high-performance features of the Holtek range of microcontrollers is attributed to their internal system architecture. The device takes advantage of the usual features found within RISC microcontrollers providing increased speed of operation and enhanced performance. The pipelining scheme is implemented in such a way that instruction fetching and instruction execution are overlapped, hence instructions are effectively executed in one or two cycles for most of the standard or extended instructions respectively. The exceptions to this are branch or call instructions which need one more cycle. An 8-bit wide ALU is used in practically all instruction set operations, which carries out arithmetic operations, logic operations, rotation, increment, decrement, branch decisions, etc. The internal data path is simplified by moving data through the Accumulator and the ALU. Certain internal registers are implemented in the Data Memory and can be directly or indirectly addressed. The simple addressing methods of these registers along with additional architectural features ensure that a minimum of external components is required to provide a functional I/O and A/D control system with maximum reliability and flexibility. This makes the device suitable for low-cost, high-volume production for controller applications.

Clocking and Pipelining

The main system clock, derived from either an HIRC, LIRC, HXT or LXT oscillator is subdivided into four internally generated non-overlapping clocks, T1~T4. The Program Counter is incremented at the beginning of the T1 clock during which time a new instruction is fetched. The remaining T2~T4 clocks carry out the decoding and execution functions. In this way, one T1~T4 clock cycle forms one instruction cycle. Although the fetching and execution of instructions takes place in consecutive instruction cycles, the pipelining structure of the microcontroller ensures that instructions are effectively executed in one instruction cycle. The exception to this are instructions where the contents of the Program Counter are changed, such as subroutine calls or jumps, in which case the instruction will take one more instruction cycle to execute.

For instructions involving branches, such as jump or call instructions, two machine cycles are required to complete instruction execution. An extra cycle is required as the program takes one cycle to first obtain the actual jump or call address and then another cycle to actually execute the branch. The requirement for this extra cycle should be taken into account by programmers in timing sensitive applications.

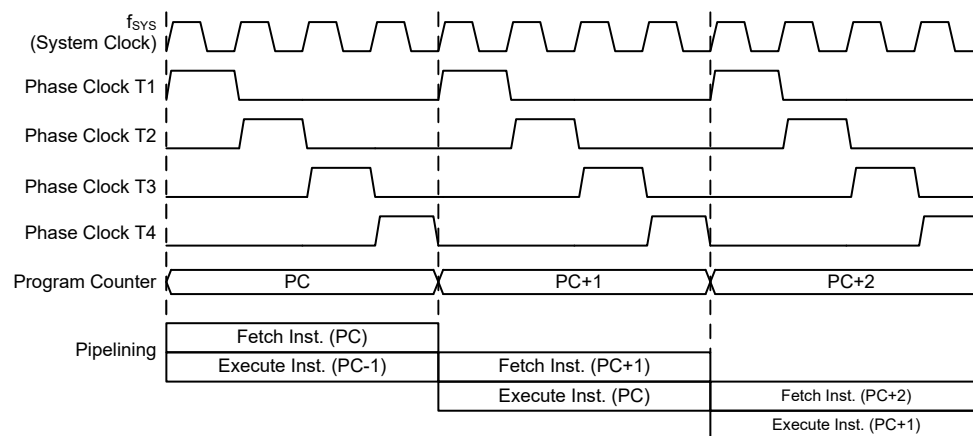

System Clocking and Pipelining

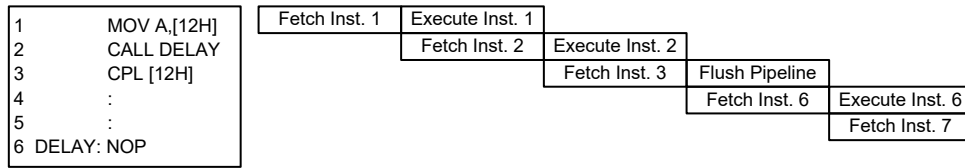

Instruction Fetching

Program Counter

During program execution, the Program Counter is used to keep track of the address of the next instruction to be executed. It is automatically incremented by one each time an instruction is executed except for instructions, such as “JMP” or “CALL” that demands a jump to a non-consecutive Program Memory address. For the device with a program memory capacity in excess of 8K words, the program memory high byte address must be setup by selecting a certain program memory bank which is implemented using the program memory bank pointer bit, PBPO. Only the lower 8 bits, known as the Program Counter Low Register, are directly addressable by the application program.

When executing instructions requiring jumps to non-consecutive addresses such as a jump instruction, a subroutine call, interrupt or reset, etc., the microcontroller manages program control by loading the required address into the Program Counter. For conditional skip instructions, once the condition has been met, the next instruction, which has already been fetched during the present instruction execution, is discarded and a dummy cycle takes its place while the correct instruction is obtained.

Program Counter	
High Byte	PCL Register
PBP0, PC12~PC8	PCL7~PCL0

Program Counter

The lower byte of the Program Counter, known as the Program Counter Low register or PCL, is available for program control and is a readable and writeable register. By transferring data directly into this register, a short program jump can be executed directly. However, as only this low byte is available for manipulation, the jumps are limited to the present page of memory that is 256 locations. When such program jumps are executed it should also be noted that a dummy cycle will be inserted. Manipulating the PCL register may cause program branching, so an extra cycle is needed to pre-fetch.

Stack

This is a special part of the memory which is used to save the contents of the Program Counter only. The stack is organized into 16 levels and is neither part of the data nor part of the program space, and is neither readable nor writeable. The activated level is indexed by the Stack Pointer, and is neither readable nor writeable. At a subroutine call or interrupt acknowledge signal, the contents of the Program Counter are pushed onto the stack. At the end of a subroutine or an interrupt routine, signaled by a return instruction, RET or RETI, the Program Counter is restored to its previous value from the stack. After a device reset, the Stack Pointer will point to the top of the stack.

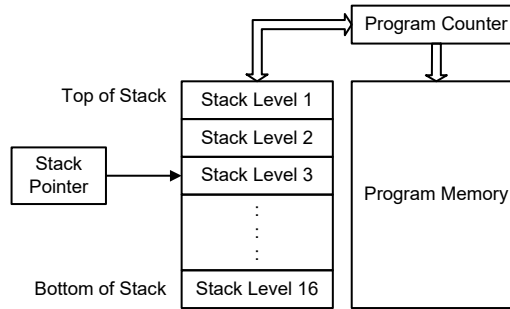

If the stack is full and an enabled interrupt takes place, the interrupt request flag will be recorded but the acknowledge signal will be inhibited. When the Stack Pointer is decremented, by RET or RETI, the interrupt will be serviced. This feature prevents stack overflow allowing the programmer to use the structure more easily. However, when the stack is full, a CALL subroutine instruction can still be executed which will result in a stack overflow. Precautions should be taken to avoid such cases which might cause unpredictable program branching. If the stack is overflow, the first Program Counter save in the stack will be lost.

Arithmetic and Logic Unit – ALU

The arithmetic-logic unit or ALU is a critical area of the microcontroller that carries out arithmetic and logic operations of the instruction set. Connected to the main microcontroller data bus, the ALU receives related instruction codes and performs the required arithmetic or logical operations after which the result will be placed in the specified register. As these ALU calculation or operations may result in carry, borrow or other status changes, the status register will be correspondingly updated to reflect these changes. The ALU supports the following functions:

- Arithmetic operations:
ADD, ADDM, ADC, ADCM, SUB, SUBM, SBC, SBCM, DAA,
LADD, LADDM, LADC, LADCM, LSUB, LSUBM, LSBC, LSBCM, LDAA
- Logic operations:
AND, OR, XOR, ANDM, ORM, XORM, CPL, CPLA,
LAND, LANDM, LOR, LORM, LXOR, LXORM, LCPL, LCPLA
- Rotation:
RRA, RR, RRCA, RRC, RLA, RL, RLCA, RLC,
LRR, LRRCA, LRRCA, LRRC, LRLA, LRL, LRLCA, LRLC
- Increment and Decrement:
INCA, INC, DECA, DEC, LINCA, LINC, LDECA, LDEC
- Branch decision:
JMP, SZ, SZA, SNZ, SIZ, SDZ, SIZA, SDZA, CALL, RET, RETI,
LSNZ, LSZ, LSZA, LSIZ, LSIZA, LSDZ, LSDZA

Flash Program Memory

The Program Memory is the location where the user code or program is stored. For this device the Program Memory is Flash type, which means it can be programmed and re-programmed a large number of times, allowing the user the convenience of code modification on the same device. By using the appropriate programming tools, the Flash device offer users the flexibility to conveniently debug and develop their applications while also offering a means of field programming and updating.

Structure

The Program Memory has a capacity of 16K×16 bits. The Program Memory is addressed by the Program Counter and also contains data, table information and interrupts entries. Table data, which can be setup in any location within the Program Memory, is addressed by a separate table pointer register.

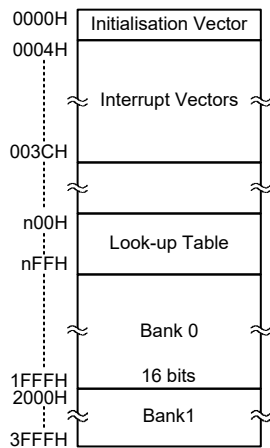

Program Memory Structure

Special Vectors

Within the Program Memory, certain locations are reserved for the reset and interrupts. The location 0000H is reserved for use by the device reset for program initialisation. After a device reset is initiated, the program will jump to this location and begin execution.

Look-up Table

Any location within the Program Memory can be defined as a look-up table where programmers can store fixed data. To use the look-up table, the table pointer must first be setup by placing the address of the look up data to be retrieved in the table pointer register, TBLP and TBHP. These registers define the total address of the look-up table.

After setting up the table pointer, the table data can be retrieved from the Program Memory using the corresponding table read instruction such as “TABRD [m]” or “TABRDL [m]” respectively when the memory [m] is located in Sector 0. If the memory [m] is located in other sectors, the data can be retrieved from the program memory using the corresponding extended table read instruction such as “LTABRD [m]” or “LTABRDL [m]” respectively. When the instruction is executed, the lower order table byte from the Program Memory will be transferred to the user defined Data Memory register [m] as specified in the instruction. The higher order table data byte from the Program Memory will be transferred to the TBLH special register.

The accompanying diagram illustrates the addressing data flow of the look-up table.

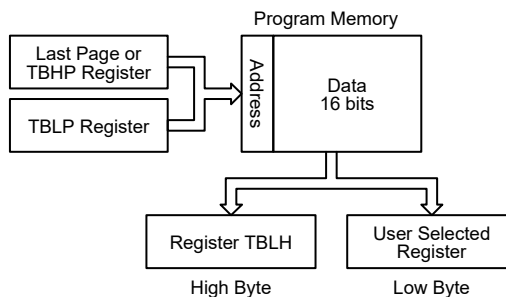

Table Program Example

The following example shows how the table pointer and table data is defined and retrieved from the microcontroller. This example uses raw table data located in the Program Memory which is stored there using the ORG statement. The value at this ORG statement is “1F00H” which is located in the Bank 1 and refers to the start address of the last page within the 16K Program Memory of the microcontroller. The table pointer low byte register is setup here to have an initial value of “06H”. This will ensure that the first data read from the data table will be at the Program Memory address “3F06H” or 6 locations after the start of the last page. Note that the value for the table pointer is referenced to the address specified by TBLP and TBHP if the “TABRD [m]” or “LTABRD [m]” instruction is being used. The high byte of the table data which in this case is equal to zero will be transferred to the TBLH register automatically when the “TABRD [m]” or “LTABRD [m]” instruction is executed.

Because the TBLH register is a read/write register and can be restored, care should be taken to ensure its protection if both the main routine and Interrupt Service Routine use table read instructions. If using the table read instructions, the Interrupt Service Routines may change the value of the TBLH and subsequently cause errors if used again by the main routine. As a rule it is recommended that simultaneous use of the table read instructions should be avoided. However, in situations where simultaneous use cannot be avoided, the interrupts should be disabled prior to the execution of any main routine table-read instructions. Note that all table related instructions require two instruction cycles to complete their operation.

Table Read Program Example

```

rombank1 code1
ds .section 'data'
tempreg1 db ? ; temporary register #1
tempreg2 db ? ; temporary register #2
:
:
code0 .section 'code'
mov a,06h ; initialise low table pointer - note that this address is referenced
mov tblp,a ; to the last page or the page that tbhp pointed
mov a,3Fh ; initialise high table pointer
mov tbhp,a
:
:
tabrd tempreg1 ; transfers value in table referenced by table pointer data at program
; memory address "3F06H" transferred to tempreg1 and TBLH
dec tblp ; reduce value of table pointer by one
tabrd tempreg2 ; transfers value in table referenced by table pointer data at program
; memory address "3F05H" transferred to tempreg2 and TBLH in this
  
```

```

; example the data "1AH" is transferred to tempreg1 and data "0FH"
; to register tempreg2
:
:
:
codel .section `code'
org 1F00h ; sets initial address of program memory
dc 00Ah, 00Bh, 00Ch, 00Dh, 00Eh, 00Fh, 01Ah, 01Bh
:

```

In Circuit Programming – ICP

The provision of Flash type Program Memory provides the user with a means of convenient and easy upgrades and modifications to their programs on the same device. As an additional convenience, Holtek has provided a means of programming the microcontroller in-circuit using a 4-pin interface. This provides manufacturers with the possibility of manufacturing their circuit boards complete with a programmed or un-programmed microcontroller, and then programming or upgrading the program at a later stage. This enables product manufacturers to easily keep their manufactured products supplied with the latest program releases without removal and re-insertion of the device.

The Flash MCU to Writer programming pins correspondence table is as follows:

Holtek Writer Pins	MCU Programming Pins	Pin Description
ICPDA	PA0	Programming serial data/address
ICPCK	PA2	Programming clock
VDD	VDD & AVDD	Power supply
VSS	VSS & AVSS	Ground

The Program Memory can be programmed serially in-circuit using this 4-wire interface. Data is downloaded and uploaded serially on a single pin with an additional line for the clock. Two additional lines are required for the power supply. The technical details regarding the in-circuit programming of the device are beyond the scope of this document and will be supplied in supplementary literature.

During the programming process, the user must take care of the ICPDA and ICPCK pins for data and clock programming purposes to ensure that no other outputs are connected to these two pins.

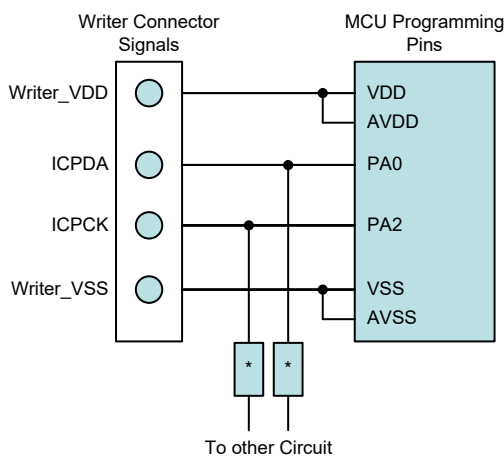

Note: * may be resistor or capacitor. The resistance of * must be greater than 1kΩ or the capacitance of * must be less than 1nF.

On-Chip Debug Support – OCDS

This device also provides an “On-Chip Debug” function to debug the device during the development process. Users can use the OCDS function to emulate the device behavior by connecting the OCDSDA and OCDSCK pins to the Holtek HT-IDE development tools. The OCDSDA pin is the OCDS Data/Address input/output pin while the OCDSCK pin is the OCDS clock input pin. When users use the OCDS function for debugging, other functions which are shared with the OCDSDA and OCDSCK pins in the device will have no effect. However, the two OCDS pins which are pin-shared with the ICP programming pins are still used as the Flash Memory programming pins for ICP. For a more detailed OCDS description, refer to the corresponding document named “Holtek e-Link for 8-bit MCU OCDS User’s Guide”.

Holtek e-Link Pins	MCU OCDS Pins	Pin Description
OCDSDA	OCDSDA	On-chip debug support data/address input/output
OCDSCK	OCDSCK	On-chip debug support clock input
VDD	VDD & AVDD	Power supply
VSS	VSS & AVSS	Ground

In Application Programming – IAP

Flash type Program Memory provides the user with a means of convenient and easy upgrades and modifications to their programs on the same device. The provision of IAP function offers users the convenience of Flash Memory multi-programming features. The convenience of the IAP function is that it can execute the updated program procedure using its internal firmware, without requiring an external Program Writer or PC. In addition, the IAP interface can also be any type of communication protocol, such as UART, using I/O pins. Regarding the internal firmware, the user can select versions provided by Holtek or create their own. The following section illustrates the procedures regarding how to implement the IAP firmware.

Flash Memory Read/Write Size

The Flash memory Erase and Write operations are carried out in a page format while the Read operation is carried out in a word format. The page size and write buffer size are both assigned with a capacity of 32 words. Note that the Erase operation should be executed before the Write operation is executed.

When the Flash Memory Erase/Write Function is successfully enabled, the CFWEN bit will be set high. When the CFWEN bit is set high, the data can be written into the write buffer. The FWT bit is used to initiate the write process and then indicate the write operation status. This bit is set high by application programs to initiate a write process and will be cleared by hardware if the write process is finished.

The Read operation can be carried out by executing a specific read procedure. The FRDEN bit is used to enable the read function and the FRD bit is used to initiate the read process by application programs and then indicate the read operation status. When the read process is finished, this bit will be cleared by hardware.

Operations	Format
Erase	32 words/page
Write	32 words/time
Read	1 word/time
Note: Page size=Write buffer size=32 words.	

IAP Read/Erase/Write Format

Page	FARH	FARL [7:5]	FARL [4:0]
0	0000 0000	000	Tag Address
1	0000 0000	001	
2	0000 0000	010	
3	0000 0000	011	
4	0000 0000	100	
5	0000 0000	101	
6	0000 0000	110	
7	0000 0000	111	
8	0000 0001	000	
9	0000 0001	001	
:	:	:	
:	:	:	
510	0011 1111	110	
511	0011 1111	111	

Page Number and Address Selection

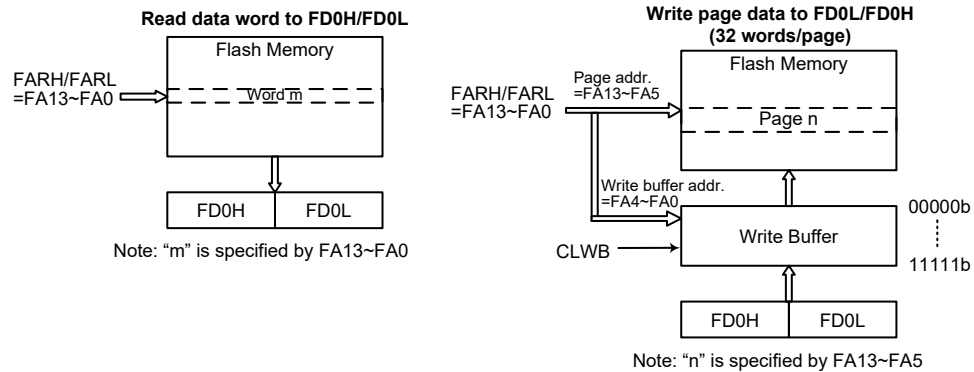

Flash Memory IAP Read/Write Structure

Write Buffer

The write buffer is used to store the written data temporarily when executing the write operation. The Write Buffer can be filled with written data after the Flash Memory Erase/Write Function has been successfully enabled by executing the Flash Memory Erase/Write Function Enable procedure. The write buffer can be cleared by configuring the CLWB bit in the FC2 register. The CLWB bit can be set high to enable the Clear Write Buffer procedure. When the procedure is finished this bit will be cleared to low by the hardware. It is recommended that the write buffer should be cleared by setting the CLWB bit high before the write buffer is used for the first time or when the data in the write buffer is updated.

The write buffer size is 32 words corresponding to a page. The write buffer address is mapped to a specific Flash memory page specified by the memory address bits, FA13~FA5. The data written into the FD0L and FD0H registers will be loaded into the write buffer. When data is written into the high byte data register, FD0H, it will result in the data stored in the high and low byte data registers both being written into the write buffer. It will also cause the flash memory address to be incremented by one, after which the new address will be loaded into the FARH and FARL address registers. When the flash memory address reaches the page boundary, 11111b of a page with 32 words, the address will now not be incremented but will stop at the last address of the page. At this point a new page address should be specified for any other erase/write operations.

After a write process is finished, the write buffer will automatically be cleared by the hardware. Note that the write buffer should be cleared manually by the application program when the data written into the flash memory is incorrect in the data verification step. The data should again be written into the write buffer after the write buffer has been cleared when the data is found to be incorrect during the data verification step.

IAP Flash Program Memory Registers

There are two address registers, four 16-bit data registers and three control registers. The address and data registers are located in Sector 0 while the control registers are located in Sector 1. Read and Write operations to the Flash memory are carried out using 16-bit data operations using the address and data registers and the control register. Several registers control the overall operation of the internal Flash Program Memory. As the FARH/FARL and FDnH/FDnL registers are located in Sector 0, they can be directly accessed in the same way as any other Special Function Register. The FC0, FC1 and FC2 registers, being located in Sector 1, can be addressed directly only using the corresponding extended instructions or can be read from or written to indirectly using the MP1H/MP1L or MP2H/MP2L Memory Pointer pairs and Indirect Addressing Register, IAR1 or IAR2.

Register Name	Bit							
	7	6	5	4	3	2	1	0
FC0	CFWEN	FMOD2	FMOD1	FMOD0	FWPEN	FWT	FRDEN	FRD
FC1	D7	D6	D5	D4	D3	D2	D1	D0
FC2	—	—	—	—	—	—	FWERTS	CLWB
FARL	FA7	FA6	FA5	FA4	FA3	FA2	FA1	FA0
FARH	—	—	FA13	FA12	FA11	FA10	FA9	FA8
FD0L	D7	D6	D5	D4	D3	D2	D1	D0
FD0H	D15	D14	D13	D12	D11	D10	D9	D8
FD1L	D7	D6	D5	D4	D3	D2	D1	D0
FD1H	D15	D14	D13	D12	D11	D10	D9	D8
FD2L	D7	D6	D5	D4	D3	D2	D1	D0
FD2H	D15	D14	D13	D12	D11	D10	D9	D8
FD3L	D7	D6	D5	D4	D3	D2	D1	D0
FD3H	D15	D14	D13	D12	D11	D10	D9	D8

IAP Register List

• FARL Register

Bit	7	6	5	4	3	2	1	0
Name	FA7	FA6	FA5	FA4	FA3	FA2	FA1	FA0
R/W	R/W	R/W	R/W	R/W	R/W	R/W	R/W	R/W
POR	0	0	0	0	0	0	0	0

Bit 7~0 **FA7~FA0**: Flash memory address bit 7 ~ bit 0

• FARH Register

Bit	7	6	5	4	3	2	1	0
Name	—	—	FA13	FA12	FA11	FA10	FA9	FA8
R/W	—	—	R/W	R/W	R/W	R/W	R/W	R/W
POR	—	—	0	0	0	0	0	0

Bit 7~6 Unimplemented, read as “0”

Bit 5~0 **FA13~FA8**: Flash memory address bit 13 ~ bit 8

• **FD0L Register**

Bit	7	6	5	4	3	2	1	0
Name	D7	D6	D5	D4	D3	D2	D1	D0
R/W	R/W	R/W	R/W	R/W	R/W	R/W	R/W	R/W
POR	0	0	0	0	0	0	0	0

Bit 7~0 **D7~D0:** The first Flash memory data word bit 7 ~ bit 0

Note that data written into the low byte data register FD0L will only be stored in the FD0L register and not loaded into the lower 8-bit write buffer.

• **FD0H Register**

Bit	7	6	5	4	3	2	1	0
Name	D15	D14	D13	D12	D11	D10	D9	D8
R/W	R/W	R/W	R/W	R/W	R/W	R/W	R/W	R/W
POR	0	0	0	0	0	0	0	0

Bit 7~0 **D15~D8:** The first Flash memory data word bit 15 ~ bit 8

Note that when 8-bit data is written into the high byte data register FD0H, the whole 16 bits of data stored in the FD0H and FD0L registers will simultaneously be loaded into the 16-bit write buffer after which the contents of the Flash memory address register pair, FARH and FARL, will be incremented by one.

• **FD1L Register**

Bit	7	6	5	4	3	2	1	0
Name	D7	D6	D5	D4	D3	D2	D1	D0
R/W	R/W	R/W	R/W	R/W	R/W	R/W	R/W	R/W
POR	0	0	0	0	0	0	0	0

Bit 7~0 **D7~D0:** The second Flash memory data word bit 7 ~ bit 0

• **FD1H Register**

Bit	7	6	5	4	3	2	1	0
Name	D15	D14	D13	D12	D11	D10	D9	D8
R/W	R/W	R/W	R/W	R/W	R/W	R/W	R/W	R/W
POR	0	0	0	0	0	0	0	0

Bit 7~0 **D15~D8:** The second Flash memory data word bit 15 ~ bit 8

• **FD2L Register**

Bit	7	6	5	4	3	2	1	0
Name	D7	D6	D5	D4	D3	D2	D1	D0
R/W	R/W	R/W	R/W	R/W	R/W	R/W	R/W	R/W
POR	0	0	0	0	0	0	0	0

Bit 7~0 **D7~D0:** The third Flash memory data word bit 7 ~ bit 0

• **FD2H Register**

Bit	7	6	5	4	3	2	1	0
Name	D15	D14	D13	D12	D11	D10	D9	D8
R/W	R/W	R/W	R/W	R/W	R/W	R/W	R/W	R/W
POR	0	0	0	0	0	0	0	0

Bit 7~0 **D15~D8:** The third Flash memory data word bit 15 ~ bit 8

• FD3L Register

Bit	7	6	5	4	3	2	1	0
Name	D7	D6	D5	D4	D3	D2	D1	D0
R/W	R/W	R/W	R/W	R/W	R/W	R/W	R/W	R/W
POR	0	0	0	0	0	0	0	0

Bit 7~0 **D7~D0**: The fourth Flash memory data word bit 7 ~ bit 0

• FD3H Register

Bit	7	6	5	4	3	2	1	0
Name	D15	D14	D13	D12	D11	D10	D9	D8
R/W	R/W	R/W	R/W	R/W	R/W	R/W	R/W	R/W
POR	0	0	0	0	0	0	0	0

Bit 7~0 **D15~D8**: The fourth Flash memory data word bit 15 ~ bit 8

• FC0 Register

Bit	7	6	5	4	3	2	1	0
Name	CFWEN	FMOD2	FMOD1	FMOD0	FWPEN	FWT	FRDEN	FRD
R/W	R/W	R/W	R/W	R/W	R/W	R/W	R/W	R/W
POR	0	0	0	0	0	0	0	0

Bit 7 **CFWEN**: Flash Memory Erase/Write enable control

0: Flash memory erase/write function is disabled

1: Flash memory erase/write function has been successfully enabled

When this bit is cleared to 0 by application program, the Flash memory write function is disabled. Note that writing a “1” into this bit results in no action. This bit is used to indicate the Flash memory write function status. When this bit is set to 1 by the hardware, it means that the Flash memory write function is enabled successfully. Otherwise, the Flash memory write function is disabled if the bit is zero.

Bit 6~4 **FMOD2~FMOD0**: Flash memory mode selection

000: Write Mode

001: Page Erase Mode

010: Reserved

011: Read Mode

100: Reserved

101: Reserved

110: Flash memory Erase/Write function Enable Mode

111: Reserved

These bits are used to select the Flash Memory operation modes. Note that the “Flash memory Erase/Write function Enable Mode” should first be successfully enabled before the Erase or Write Flash memory operation is executed.

Bit 3 **FWPEN**: Flash memory Erase/Write function enable procedure Trigger

0: Erase/Write function enable procedure is not triggered or procedure timer times out

1: Erase/Write function enable procedure is triggered and procedure timer starts to count

This bit is used to activate the Flash memory Erase/Write function enable procedure and an internal timer. It is set by the application programs and then cleared by hardware when the internal timer times out. The correct patterns must be written into the FD1L/FD1H, FD2L/FD2H and FD3L/FD3H register pairs respectively as soon as possible after the FWPEN bit is set high.

- Bit 2 **FWT**: Flash memory write initiate control
 0: Do not initiate Flash memory write or indicating that a Flash memory write process has completed
 1: Initiate Flash memory write process
 This bit is set by software and cleared to 0 by the hardware when the Flash memory write process has completed.
- Bit 1 **FRDEN**: Flash memory read enable control
 0: Flash memory read disable
 1: Flash memory read enable
 This is the Flash memory Read Enable Bit which must be set high before any Flash memory read operations are carried out. Clearing this bit to zero will inhibit Flash memory read operations.
- Bit 0 **FRD**: Flash memory read initiate control
 0: Do not initiate Flash memory read or indicating that a Flash memory read process has completed
 1: Initiate Flash memory read process
 This bit is set by software and cleared to 0 by the hardware when the Flash memory read process has completed.

- Note: 1. The FWT, FRDEN and FRD bits cannot be set to “1” at the same time with a single instruction.
 2. Ensure that the f_{SUB} clock is stable before executing the erase/write operation.
 3. Note that the CPU will be stopped when a read, write or erase operation is successfully activated.
 4. Ensure that the read/erase/write operation is totally complete before executing other operations.

• **FC1 Register**

Bit	7	6	5	4	3	2	1	0
Name	D7	D6	D5	D4	D3	D2	D1	D0
R/W	R/W	R/W	R/W	R/W	R/W	R/W	R/W	R/W
POR	0	0	0	0	0	0	0	0

- Bit 7~0 **D7~D0**: Chip reset pattern
 When a specific value of “55H” is written into this register, a reset signal will be generated to reset the whole chip.

• **FC2 Register**

Bit	7	6	5	4	3	2	1	0
Name	—	—	—	—	—	—	FWERTS	CLWB
R/W	—	—	—	—	—	—	R/W	R/W
POR	—	—	—	—	—	—	0	0

- Bit 7~2 Unimplemented, read as “0”
- Bit 1 **FWERTS**: Erase time and Write time select
 0: Erase time is 3.2ms (t_{FER}) / Write time is 2.2ms (t_{FWR})
 1: Erase time is 3.7ms (t_{FER}) / Write time is 3.0ms (t_{FWR})
- Bit 0 **CLWB**: Flash memory write buffer clear control
 0: Do not initiate a Write Buffer Clear process or indicating that a Write Buffer Clear process has completed
 1: Initiate Write Buffer Clear process
 This bit is set by software and cleared to 0 by hardware when the Write Buffer Clear process has completed.

Flash Memory Erase/Write Flow

It is important to understand the Flash memory Erase/Write flow before the Flash memory contents are updated. Users can refer to the corresponding operation procedures when developing their IAP program to ensure that the flash memory contents are correctly updated.

Flash Memory Erase/Write Flow Descriptions:

1. Activate the “Flash Memory Erase/Write function enable procedure” first. When the Flash Memory Erase/Write function is successfully enabled, the CFWEN bit in the FC0 register will automatically be set high by hardware. After this, Erase or Write operations can be executed on the Flash memory. Refer to the “Flash Memory Erase/Write Function Enable Procedure” for details.
2. Configure the flash memory address to select the desired erase page, tag address and then erase this page. For a page erase operation, set the FARL and FARH registers to specify the start address of the erase page, then write dummy data into the FD0H register to tag address. The current address will be internally incremented by one after each dummy data is written into the FD0H register. When the address reaches the page boundary, 11111b, the address will not be further incremented but stop at the last address of the page. Note that the write operation to the FD0H register is used to tag address, it must be implemented to determine which addresses to be erased.
3. Execute a Blank Check operation to ensure whether the page erase operation is successful or not. The “TABRD” instruction should be executed to read the flash memory contents and to check if the contents is 0000h or not. If the flash memory page erase operation fails, users should go back to Step 2 and execute the page erase operation again.
4. Write data into the specific page. Refer to the “Flash Memory Write Procedure” for details.
5. Execute the “TABRD” instruction to read the flash memory contents and check if the written data is correct or not. If the data read from the flash memory is different from the written data, it means that the page write operation has failed. The CLWB bit should be set high to clear the write buffer and then write the data into the specific page again if the write operation has failed.
6. Clear the CFWEN bit to disable the Flash Memory Erase/Write function enable mode if the current page Erase and Write operations are complete if no more pages need to be erased or written.

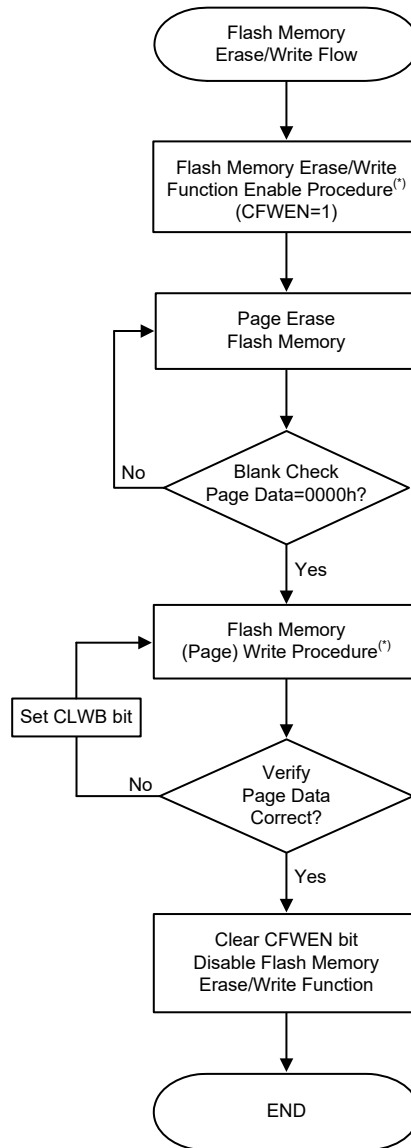

Flash Memory Erase/Write Flow

Note: The Flash Memory Erase/Write Function Enable procedure and Flash Memory Write procedure will be described in the following sections.

Flash Memory Erase/Write Function Enable Procedure

The Flash Memory Erase/Write Function Enable Mode is specially designed to prevent the flash memory contents from being wrongly modified. In order to allow users to change the Flash memory data using the IAP control registers, users must first enable the Flash memory Erase/Write function.

Flash Memory Erase/Write Function Enable Procedure Description

1. Write data “110” to the FMOD [2:0] bits in the FC0 register to select the Flash Memory Erase/Write Function Enable Mode.
2. Set the FWPEN bit in the FC0 register to “1” . The step 1 and step 2 can be executed simultaneously.
3. Write the correct data pattern into the Flash data registers, FD1L~FD3L and FD1H~FD3H, as soon as possible after the FWPEN bit is set high. The enable Flash memory erase/write function data pattern is 00H, 0DH, C3H, 04H, 09H and 40H corresponding to the FD1L~FD3L and FD1H~FD3H registers respectively.
4. Once the timer has timed out, the FWPEN bit will automatically be cleared to 0 by hardware regardless of the input data pattern.
5. If the written data pattern is incorrect, the Flash memory erase/write function will not be enabled successfully and the above steps should be repeated. If the written data pattern is correct, the Flash memory erase/write function will be enabled successfully.
6. Once the Flash memory write function is enabled, the Flash memory contents can be updated by executing the page erase and write operations using the IAP control registers.

To disable the Flash memory write function, the CFWEN bit in the FC0 register can be cleared. There is no need to execute the above procedure.

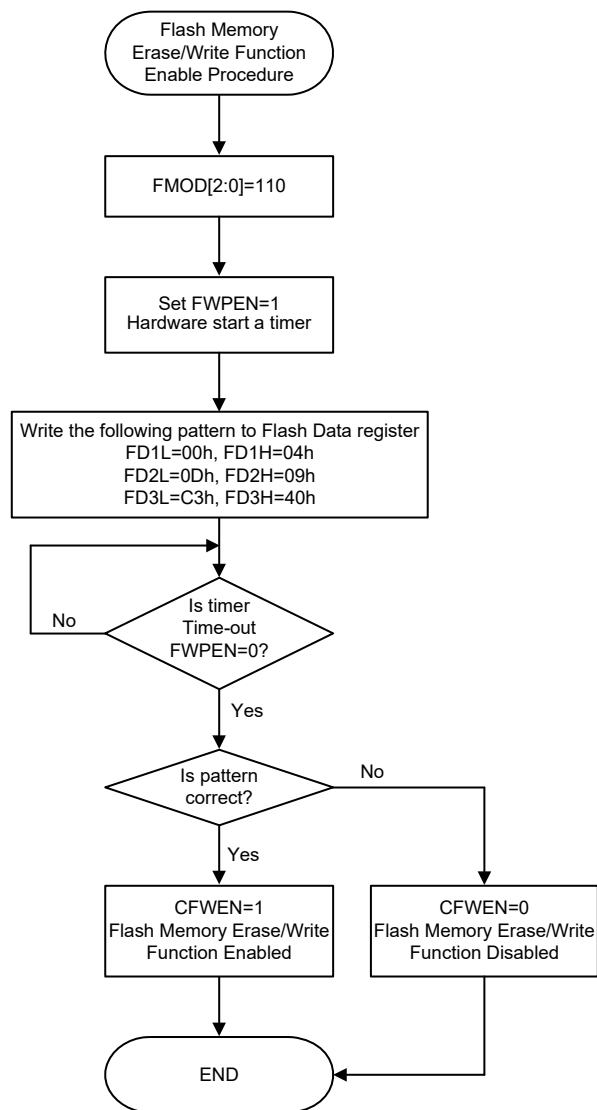

Flash Memory Erase/Write Function Enable Procedure

Flash Memory Write Procedure

After the Flash memory erase/write function has been successfully enabled as the CFWEN bit is set high, the data to be written into the flash memory can be loaded into the write buffer. The selected flash memory page data should be erased by properly configuring the IAP control registers before the data write procedure is executed.

The write buffer size is 32 words, known as a page, whose address is mapped to a specific flash memory page specified by the memory address bits, FA13~FA5. It is important to ensure that the page where the write buffer data is located is the same one which the memory address bits, FA13~FA5, specify.

Flash Memory Consecutive Write Description

The maximum amount of write data is 32 words for each write operation. The write buffer address will be automatically incremented by one when consecutive write operations are executed. The start address of a specific page should first be written into the FARL and FARH registers. Then the data word should first be written into the FD0L register and then the FD0H register. At the same time the write buffer address will be incremented by one and then the next data word can be written into the FD0L and FD0H registers for the next address without modifying the address register pair, FARH and FARL. When the write buffer address reaches the page boundary the address will not be further incremented but will stop at the last address of the page.

1. Activate the “Flash Memory Erase/Write function enable procedure”. Check the CFWEN bit value and then execute the erase/write operations if the CFWEN bit is set high. Refer to the “Flash Memory Erase/Write function enable procedure” for more details.
2. Set the FMOD field to “001” to select the erase operation and set the CLWB bit high to clear the write buffer. Set the FWT bit high to erase the desired page which is specified by the FARH and FARL registers and has been tagged address. Wait until the FWT bit goes low.
3. Execute a Blank Check operation using the table read instruction to ensure that the erase operation has successfully completed.
Go to step 2 if the erase operation is not successful.
Go to step 4 if the erase operation is successful.
4. Set the FMOD field to “000” to select the write operation.
5. Setup the desired start address in the FARH and FARL registers. Write the desired data words consecutively into the FD0L and FD0H registers within a page as specified by their consecutive addresses. The maximum written data number is 32 words.
6. Set the FWT bit high to write the data words from the write buffer to the flash memory. Wait until the FWT bit goes low.
7. Verify the data using the table read instruction to ensure that the write operation has successfully completed.
If the write operation has not successfully completed, set the CLWB bit high to clear the write buffer and then go to step 5.
Go to step 8 if the write operation is successful.
8. Clear the CFWEN bit low to disable the Flash memory erase/write function.

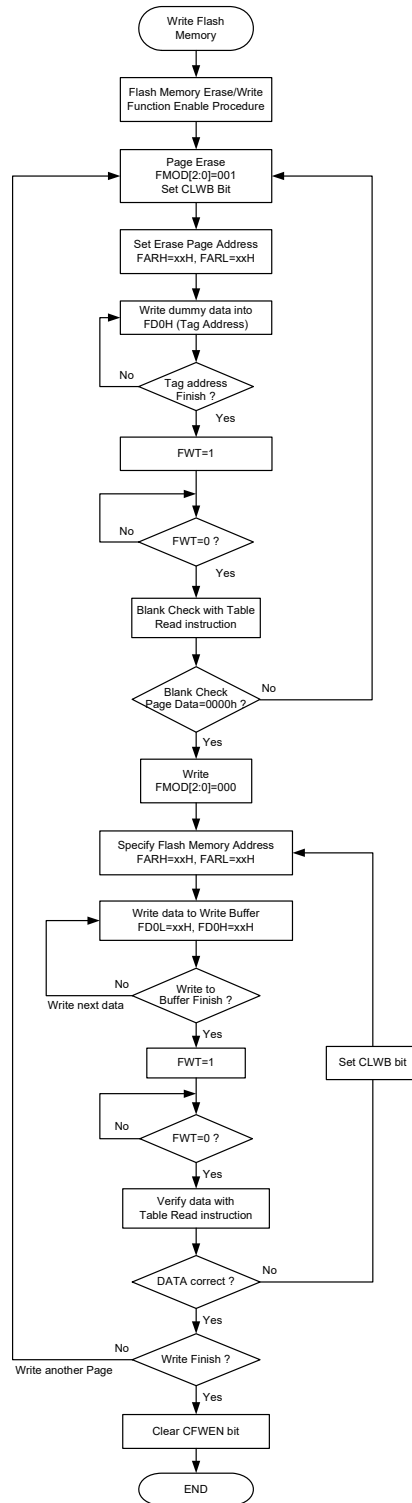

Flash Memory Consecutive Write Procedure

- Note: 1. When the erase or write operation is successfully activated, all CPU operations will temporarily cease.
 2. It will take certain time for the FWT bit state changing from high to low in the erase or write operation, which can be selected by the FWERTS bit in the FC2 register.

Flash Memory Non-Consecutive Write Description

The main difference between Flash Memory Consecutive and Non-Consecutive Write operations is whether the data words to be written are located in consecutive addresses or not. If the data to be written is not located in consecutive addresses the desired address should be re-assigned after a data word is successfully written into the Flash Memory.

A two data word non-consecutive write operation is taken as an example here and described as follows:

1. Activate the “Flash Memory Erase/Write function enable procedure”. Check the CFWEN bit value and then execute the erase/write operation if the CFWEN bit is set high. Refer to the “Flash Memory Erase/Write function enable procedure” for more details.
2. Set the FMOD field to “001” to select the erase operation and set the CLWB bit high to clear the write buffer. Set the FWT bit high to erase the desired page which is specified by the FARH and FARL registers and has been tagged address. Wait until the FWT bit goes low.
3. Execute a Blank Check operation using the table read instruction to ensure that the erase operation has successfully completed.
Go to step 2 if the erase operation is not successful.
Go to step 4 if the erase operation is successful.
4. Set the FMOD field to “000” to select the write operation.
5. Setup the desired address ADDR1 in the FARH and FRARL registers. Write the desired data word DATA1 first into the FD0L register and then into the FD0H register.
6. Set the FWT bit high to transfer the data word from the write buffer to the flash memory. Wait until the FWT bit goes low.
7. Verify the data using the table read instruction to ensure that the write operation has successfully completed.
If the write operation has not successfully completed, set the CLWB bit high to clear the write buffer and then go to step 5.
Go to step 8 if the write operation is successful.
8. Setup the desired address ADDR2 in the FARH and FRARL registers. Write the desired data word DATA2 first into the FD0L register and then into the FD0H register.
9. Set the FWT bit high to transfer the data word from the write buffer to the flash memory. Wait until the FWT bit goes low.
10. Verify the data using the table read instruction to ensure that the write operation has successfully completed.
If the write operation has not successfully completed, set the CLWB bit high to clear the write buffer and then go to step 8.
Go to step 11 if the write operation is successful.
11. Clear the CFWEN bit low to disable the Flash memory erase/write function.

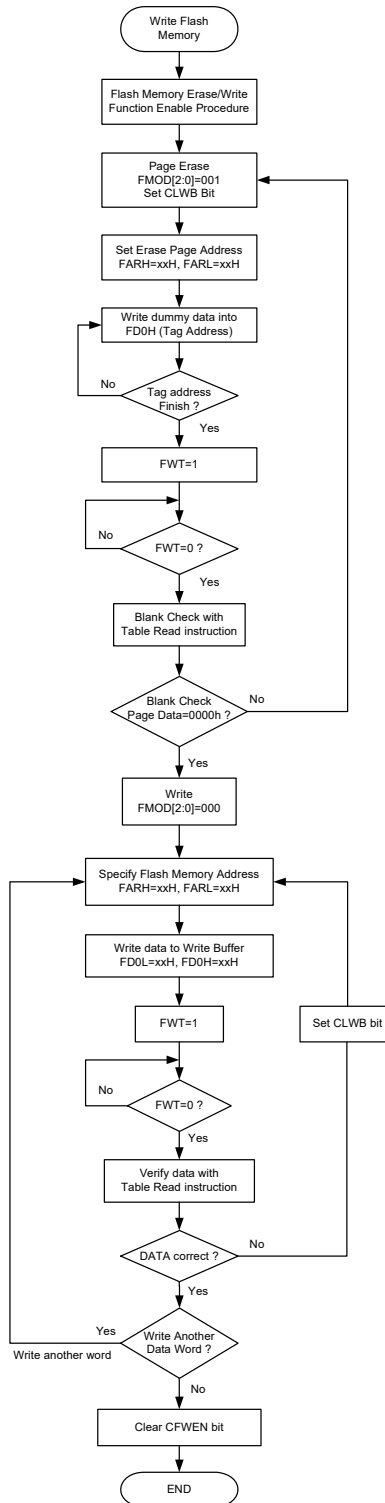

Flash Memory Non-Consecutive Write Procedure

- Note: 1. When the erase or write operation is successfully activated, all CPU operations will temporarily cease.
 2. It will take certain time for the FWT bit state changing from high to low in the erase or write operation, which can be selected by the FWERTS bit in the FC2 register.

Important Points to Note for Flash Memory Write Operations

1. The “Flash Memory Erase/Write Function Enable Procedure” must be successfully activated before the Flash Memory erase/write operation is executed.
2. The Flash Memory erase operation is executed to erase a whole page.
3. The whole write buffer data will be written into the flash memory in a page format. The corresponding address cannot exceed the page boundary.
4. After the data is written into the flash memory the flash memory contents must be read out using the table read instruction, TABRD, and checked if it is correct or not. If the data written into the flash memory is incorrect, the write buffer should be cleared by setting the CLWB bit high and then writing the data again into the write buffer. Then activate a write operation on the same flash memory page without erasing it. The data check, buffer clear and data re-write steps should be repeatedly executed until the data written into the flash memory is correct.
5. The system frequency should be setup to the maximum application frequency when data write and data check operations are executed using the IAP function.

Flash Memory Read Procedure

To activate the Flash Memory Read procedure, the FMOD field should be set to “011” to select the flash memory read mode and the FRDEN bit should be set high to enable the read function. The desired flash memory address should be written into the FARH and FARL registers and then the FRD bit should be set high. After this the flash memory read operation will be activated. The data stored in the specified address can be read from the data registers, FD0H and FD0L, when the FRD bit goes low. There is no need to first activate the Flash Memory Erase/Write Function Enable Procedure before the flash memory read operation is executed.

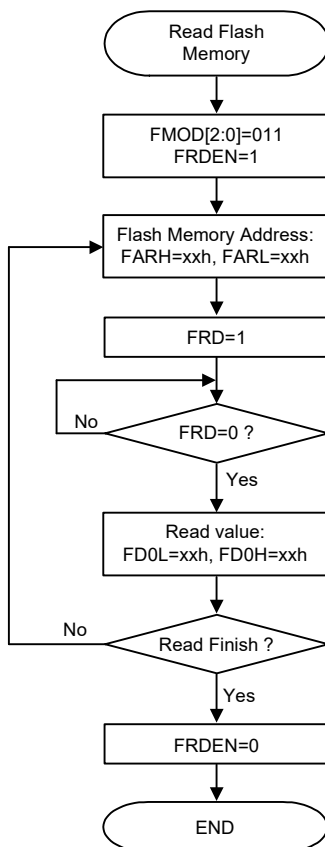

Flash Memory Read Procedure

- Note: 1. When the read operation is successfully activated, all CPU operations will temporarily cease.
2. It will take a typical time of three instruction cycles for the FRD bit state changing from high to low.

RAM Data Memory

The Data Memory is a volatile area of 8-bit wide RAM internal memory and is the location where temporary information is stored.

Categorized into two types, the first of these is an area of RAM where special function registers are located. These registers have fixed locations and are necessary for correct operation of the device. Many of these registers can be read from and written to directly under program control, however, some remain protected from user manipulation. The second area of Data Memory is reserved for general purpose use. All locations within this area are read and write accessible under program control.

Structure

The Data Memory is subdivided into several sectors, all of which are implemented in 8-bit wide Memory.

Each of the Data Memory sectors is categorized into two types, the Special Purpose Data Memory and the General Purpose Data Memory. The address range of the Special Purpose Data Memory for the device is from 00H to 7FH while the General Purpose Data Memory address range is from 80H to FFH.

Switching between the different Data Memory sectors is achieved by setting the Memory Pointers to the correct value if using the indirect addressing method. The start address of the Data Memory for the device is the address 00H.

Special Purpose Data Memory	General Purpose Data Memory	
Available Sectors	Capacity	Sector: Address
0, 1	2048×8	0: 80H~FFH 1: 80H~FFH : 15: 80H~FFH

Data Memory Summary

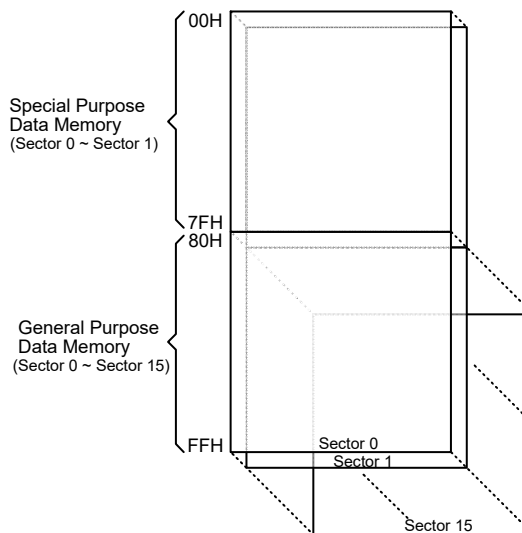

Data Memory Structure

Data Memory Addressing

For the device that supports the extended instructions, there is no Bank Pointer for Data Memory. The Bank Pointer, PBP, is only available for Program Memory. For Data Memory the desired Sector is pointed by the MP1H or MP2H register and the certain Data Memory address in the selected sector is specified by the MP1L or MP2L register when using indirect addressing access.

Direct Addressing can be used in all sectors using the extended instructions which can address all available data memory space. For the accessed data memory which is located in any data memory sectors except Sector 0, the extended instructions can be used to access the data memory instead of using the indirect addressing access. The main difference between standard instructions and extended instructions is that the data memory address “m” in the extended instructions has 12 valid bits for this device, the high byte indicates a sector and the low byte indicates a specific address.

General Purpose Data Memory

All microcontroller programs require an area of read/write memory where temporary data can be stored and retrieved for use later. It is this area of RAM memory that is known as General Purpose Data Memory. This area of Data Memory is fully accessible by the user programming for both reading and writing operations. By using the bit operation instructions individual bits can be set or reset under program control giving the user a large range of flexibility for bit manipulation in the Data Memory.

Special Purpose Data Memory

This area of Data Memory is where registers, necessary for the correct operation of the microcontroller, are stored. Most of the registers are both readable and writeable but some are protected and are readable only, the details of which are located under the relevant Special Function Register section. Note that for locations that are unused, any read instruction to these addresses will return the value “00H”.

	Sector 0	Sector 1		Sector 0	Sector 1
00H	IAR0	PTM0C0	40H	LVDC	EEC
01H	MP0	PTM0C1	41H	EEAL	U1SR
02H	IAR1	PTM0DL	42H	EEAH	U1CR1
03H	MP1L	PTM0DH	43H	EED	U1CR2
04H	MP1H	PTM0AL	44H		BRDH1
05H	ACC	PTM0AH	45H	CMP1C	BRDL1
06H	PCL	PTM0RPL	46H	MF10	UFCR1
07H	TBLP	PTM0RPH	47H	MF11	TXR_RXR1
08H	TBLH	STM0C0	48H	MF12	RxCNT1
09H	TBHP	STM0C1	49H	MF13	IFS0
0AH	STATUS	STM0DL	4AH	MF14	IFS1
0BH	PBP	STM0DH	4BH	MF15	IFS2
0CH	IAR2	STM0AL	4CH		IFS3
0DH	MP2L	STM0AH	4DH		
0EH	MP2H	STM0RP	4EH		PAS0
0FH	RSTFC	FC0	4FH		PAS1
10H	INTC0	FC1	50H	SCOMC	PBS0
11H	INTC1	FC2	51H		PBS1
12H	INTC2	U0SR	52H		PCS0
13H	INTC3	U0CR1	53H	SLEDC0	PCS1
14H	PA	U0CR2	54H	SLEDC1	PDS0
15H	PAC	BRDH0	55H	SLEDC2	PDS1
16H	PAPU	BRDL0	56H		PES0
17H	PAWU	UFCR0	57H		PES1
18H	PB	TXR_RXR0	58H		PFS0
19H	PBC	RxCNT0	59H	MDUWR0	PFS1
1AH	PBPU	PTM1C0	5AH	MDUWR1	
1BH	PC	PTM1C1	5BH	MDUWR2	
1CH	PCC	PTM1DL	5CH	MDUWR3	
1DH	PCPU	PTM1DH	5DH	MDUWR4	
1EH	PD	PTM1AL	5EH	MDUWR5	
1FH	PDC	PTM1AH	5FH	MDUWCTRL	
20H	PDPU	PTM1RPL	60H		
21H	PE	PTM1RPH	61H	CMP1VOS	
22H	PEC	PTM2C0	62H		
23H	PEPU	PTM2C1	63H	PSC0R	
24H	PF	PTM2DL	64H	TB0C	
25H	PFC	PTM2DH	65H	TB1C	
26H	PFPU	PTM2AL	66H	PSC1R	
27H		PTM2AH	67H	SADOL	
28H		PTM2RPL	68H	SADOH	
29H		PTM2RPH	69H	SADC0	
2AH		PTM3C0	6AH	SADC1	
2BH		PTM3C1	6BH	SADC2	
2CH		PTM3DL	6CH	SIMC0	
2DH		PTM3DH	6DH	SIMC1	
2EH		PTM3AL	6EH	SIMD	
2FH		PTM3AH	6FH	SIMC2/SIMA	
30H	CRCCR	PTM3RPL	70H	SIMTOC	
31H	CRCIN	PTM3RPH	71H		
32H	CRCDL	STM1C0	72H		
33H	CRCDH	STM1C1	73H		
34H	IECC	STM1DL	74H	FARL	
35H	PMPS	STM1DH	75H	FARH	
36H	RSTC	STM1AL	76H	FD0L	
37H	VBGRC	STM1AH	77H	FD0H	
38H		STM1RP	78H	FD1L	
39H	INTEG		79H	FD1H	
3AH	SCC		7AH	FD2L	
3BH	HIRCC		7BH	FD2H	
3CH	HXTC		7CH	FD3L	
3DH	LXTC		7DH	FD3H	
3EH	WDTC		7EH		
3FH	LVRC		7FH	LVPU	

□ : Unused, read as 00H

▣ : Reserved, cannot be changed

Special Purpose Data Memory

Special Function Register Description

Most of the Special Function Register details will be described in the relevant functional sections, however several registers require a separate description in this section.

Indirect Addressing Registers – IAR0, IAR1, IAR2

The Indirect Addressing Registers, IAR0, IAR1 and IAR2, although having their locations in normal RAM register space, do not actually physically exist as normal registers. The method of indirect addressing for RAM data manipulation uses these Indirect Addressing Registers and Memory Pointers, in contrast to direct memory addressing, where the actual memory address is specified. Actions on the IAR0, IAR1 and IAR2 registers will result in no actual read or write operation to these registers but rather to the memory location specified by their corresponding Memory Pointers, MP0, MP1L/MP1H or MP2L/MP2H. Acting as a pair, IAR0 and MP0 can together access data only from Sector 0 while the IAR1 register together with the MP1L/MP1H register pair and IAR2 register together with the MP2L/MP2H register pair can access data from any Data Memory Sector. As the Indirect Addressing Registers are not physically implemented, reading the Indirect Addressing Registers will return a result of “00H” and writing to the registers will result in no operation.

Memory Pointers – MP0, MP1L/MP1H, MP2L/MP2H

Five Memory Pointers, known as MP0, MP1L/MP1H, MP2L/MP2H, are provided. These Memory Pointers are physically implemented in the Data Memory and can be manipulated in the same way as normal registers providing a convenient way with which to address and track data. When any operation to the relevant Indirect Addressing Registers is carried out, the actual address that the microcontroller is directed to is the address specified by the related Memory Pointer. MP0, together with Indirect Addressing Register, IAR0, are used to access data from Sector 0, while MP1L/MP1H together with IAR1 and MP2L/MP2H together with IAR2 are used to access data from all sectors according to the corresponding MP1H or MP2H register. Direct Addressing can be used in all sectors using the corresponding instruction which can address all available data memory space.

The following example shows how to clear a section of four Data Memory locations already defined as locations `adres1` to `adres4`.

Indirect Addressing Program Example 1

```
data .section 'data'
adres1 db ?
adres2 db ?
adres3 db ?
adres4 db ?
block db ?
code .section at 0 'code'
org 00h
start:
    mov a, 04h                ; setup size of block
    mov block, a
    mov a, offset adres1     ; Accumulator loaded with first RAM address
    mov mp0, a               ; setup memory pointer with first RAM address
loop:
    clr IAR0                 ; clear the data at address defined by MP0
    inc mp0                  ; increment memory pointer
    sdz block                ; check if last memory location has been cleared
    jmp loop
continue:
```

Indirect Addressing Program Example 2

```

data .section 'data'
adres1 db ?
adres2 db ?
adres3 db ?
adres4 db ?
block db ?
code .section at 0 'code'
org 00h
start:
    mov a, 04h            ; setup size of block
    mov block, a
    mov a, 01h           ; setup the memory sector
    mov mplh, a
    mov a, offset adres1 ; Accumulator loaded with first RAM address
    mov mp1l, a          ; setup memory pointer with first RAM address
loop:
    clr IAR1            ; clear the data at address defined by MP1L
    inc mp1l            ; increment memory pointer MP1L
    sdz block           ; check if last memory location has been cleared
    jmp loop
continue:

```

The important point to note here is that in the example shown above, no reference is made to specific Data Memory addresses.

Direct Addressing Program Example using extended instructions

```

data .section 'data'
temp db ?
code .section at 0 'code'
org 00h
start:
    lmov a, [m]          ; move [m] data to acc
    lsub a, [m+1]        ; compare [m] and [m+1] data
    snz c               ; [m]>[m+1]?
    jmp continue        ; no
    lmov a, [m]          ; yes, exchange [m] and [m+1] data
    mov temp, a
    lmov a, [m+1]
    lmov [m], a
    mov a, temp
    lmov [m+1], a
continue:

```

Note: Here “m” is a data memory address located in any data memory sectors. For example, m=1F0H, it indicates address 0F0H in Sector 1.

Program Memory Bank Pointer – PBP

For the device the program memory is divided into two banks. Selecting the required program memory area is achieved using the program memory bank pointer, PBP. The PBP register should be properly configured before the device executes the “Branch” operation using the “JMP” or “CALL” instruction. After that a jump to a non-consecutive program memory address which is located in a certain bank selected by the program memory bank pointer bits will occur.

• **PBP Register**

Bit	7	6	5	4	3	2	1	0
Name	—	—	—	—	—	—	—	PBP0
R/W	—	—	—	—	—	—	—	R/W
POR	—	—	—	—	—	—	—	0

Bit 7~1 Unimplemented, read as “0”
 Bit 0 **PBP0**: Program memory bank pointer bit 0
 0: Bank 0
 1: Bank 1

Accumulator – ACC

The Accumulator is central to the operation of any microcontroller and is closely related with operations carried out by the ALU. The Accumulator is the place where all intermediate results from the ALU are stored. Without the Accumulator it would be necessary to write the result of each calculation or logical operation such as addition, subtraction, shift, etc., to the Data Memory resulting in higher programming and timing overheads. Data transfer operations usually involve the temporary storage function of the Accumulator; for example, when transferring data between one user-defined register and another, it is necessary to do this by passing the data through the Accumulator as no direct transfer between two registers is permitted.

Program Counter Low Register – PCL

To provide additional program control functions, the low byte of the Program Counter is made accessible to programmers by locating it within the Special Purpose area of the Data Memory. By manipulating this register, direct jumps to other program locations are easily implemented. Loading a value directly into this PCL register will cause a jump to the specified Program Memory location. However, as the register is only 8-bit wide, only jumps within the current Program Memory page are permitted. When such operations are used, note that a dummy cycle will be inserted.

Look-up Table Registers – TBLP, TBHP, TBLH

These three special function registers are used to control operation of the look-up table which is stored in the Program Memory. TBLP and TBHP are the table pointers and indicate the location where the table data is located. Their value must be setup before any table read commands are executed. Their value can be changed, for example using the “INC” or “DEC” instructions, allowing for easy table data pointing and reading. TBLH is the location where the high order byte of the table data is stored after a table read data instruction has been executed. Note that the lower order table data byte is transferred to a user defined location.

Status Register – STATUS

This 8-bit register contains the SC flag, CZ flag, zero flag (Z), carry flag (C), auxiliary carry flag (AC), overflow flag (OV), power down flag (PDF), and watchdog time-out flag (TO). These arithmetic/logical operation and system management flags are used to record the status and operation of the microcontroller.

With the exception of the TO and PDF flags, bits in the status register can be altered by instructions like most other registers. Any data written into the status register will not change the TO or PDF flag. In addition, operations related to the status register may give different results due to the different instruction operations. The TO flag can be affected only by a system power-up, a WDT time-out or by executing the “CLR WDT” or “HALT” instruction. The PDF flag is affected only by executing the “HALT” or “CLR WDT” instruction or during a system power-up.

The Z, OV, AC, C, SC and CZ flags generally reflect the status of the latest operations.

- C is set if an operation results in a carry during an addition operation or if a borrow does not take place during a subtraction operation; otherwise C is cleared. C is also affected by a rotate through carry instruction.
- AC is set if an operation results in a carry out of the low nibbles in addition, or no borrow from the high nibble into the low nibble in subtraction; otherwise AC is cleared.
- Z is set if the result of an arithmetic or logical operation is zero; otherwise Z is cleared.
- OV is set if an operation results in a carry into the highest-order bit but not a carry out of the highest-order bit, or vice versa; otherwise OV is cleared.
- PDF is cleared by a system power-up or executing the “CLR WDT” instruction. PDF is set by executing the “HALT” instruction.
- TO is cleared by a system power-up or executing the “CLR WDT” or “HALT” instruction. TO is set by a WDT time-out.
- CZ is the operational result of different flags for different instructions. Refer to register definitions for more details.
- SC is the result of the “XOR” operation which is performed by the OV flag and the MSB of the current instruction operation result.

In addition, on entering an interrupt sequence or executing a subroutine call, the status register will not be pushed onto the stack automatically. If the contents of the status registers are important and if the subroutine can corrupt the status register, precautions must be taken to correctly save it.

• STATUS Register

Bit	7	6	5	4	3	2	1	0
Name	SC	CZ	TO	PDF	OV	Z	AC	C
R/W	R/W	R/W	R	R	R/W	R/W	R/W	R/W
POR	x	x	0	0	x	x	x	x

“x”: Unknown

- Bit 7 **SC**: The result of the “XOR” operation which is performed by the OV flag and the MSB of the instruction operation result.
- Bit 6 **CZ**: The operational result of different flags for different instructions.
For SUB/SUBM/LSUB/LSUBM instructions, the CZ flag is equal to the Z flag.
For SBC/SBCM/LSBC/LSBCM instructions, the CZ flag is the “AND” operation result which is performed by the previous operation CZ flag and current operation zero flag.
For other instructions, the CZ flag will not be affected.
- Bit 5 **TO**: Watchdog time-out flag
0: After power up or executing the “CLR WDT” or “HALT” instruction
1: A watchdog time-out occurred.
- Bit 4 **PDF**: Power down flag
0: After power up or executing the «CLR WDT” instruction
1: By executing the “HALT” instruction
- Bit 3 **OV**: Overflow flag
0: No overflow
1: An operation results in a carry into the highest-order bit but not a carry out of the highest-order bit or vice versa.
- Bit 2 **Z**: Zero flag
0: The result of an arithmetic or logical operation is not zero
1: The result of an arithmetic or logical operation is zero

- Bit 1 **AC:** Auxiliary flag
 0: No auxiliary carry
 1: An operation results in a carry out of the low nibbles in addition, or no borrow from the high nibble into the low nibble in subtraction
- Bit 0 **C:** Carry flag
 0: No carry-out
 1: An operation results in a carry during an addition operation or if a borrow does not take place during a subtraction operation
- The “C” flag is also affected by a rotate through carry instruction.

EEPROM Data Memory

This device contains an area of internal EEPROM Data Memory. EEPROM is by its nature a non-volatile form of re-programmable memory, with data retention even when its power supply is removed. By incorporating this kind of data memory, a whole new host of application possibilities are made available to the designer. The availability of EEPROM storage allows information such as product identification numbers, calibration values, specific user data, system setup data or other product information to be stored directly within the product microcontroller. The process of reading and writing data to the EEPROM memory has been reduced to a very trivial affair.

EEPROM Data Memory Structure

The EEPROM Data Memory capacity is 1024×8 bits for the device. Unlike the Program Memory and RAM Data Memory, the EEPROM Data Memory is not directly mapped into memory space and is therefore not directly addressable in the same way as the other types of memory. Read and Write operations to the EEPROM are carried out in single byte operations using an address register pair and a data register in Sector 0 and a single control register in Sector 1.

EEPROM Registers

Four registers control the overall operation of the internal EEPROM Data Memory. These are the address registers, EEAL and EEAH, the data register, EED and a single control register, EEC. As both the EEAH, EEAL and EED registers are located in Sector 0, they can be directly accessed in the same way as any other Special Function Register. The EEC register however, being located in Sector 1, can only be read from or written to indirectly using the MP1L/MP1H or MP2L/MP2H Memory Pointer and Indirect Addressing Register, IAR1/IAR2. Because the EEC control register is located at address 40H in Sector 1, the MP1L or MP2L Memory Pointer must first be set to the value 40H and the MP1H or MP2H Memory Pointer high byte set to the value, 01H, before any operations on the EEC register are executed.

Register Name	Bit							
	7	6	5	4	3	2	1	0
EEAL	EEAL7	EEAL6	EEAL5	EEAL4	EEAL3	EEAL2	EEAL1	EEAL0
EEAH	—	—	—	—	—	—	EEAH1	EEAH0
EED	D7	D6	D5	D4	D3	D2	D1	D0
EEC	EWERTS	EREN	ER	MODE	WREN	WR	RDEN	RD

EEPROM Register List

• EEAL Register

Bit	7	6	5	4	3	2	1	0
Name	EEAL7	EEAL6	EEAL5	EEAL4	EEAL3	EEAL2	EEAL1	EEAL0
R/W	R/W	R/W	R/W	R/W	R/W	R/W	R/W	R/W
POR	0	0	0	0	0	0	0	0

Bit 7~0 **EEAL7~EEAL0**: Data EEPROM low byte address bit 7 ~ bit 0

• EEAH Register

Bit	7	6	5	4	3	2	1	0
Name	—	—	—	—	—	—	EEAH1	EEAH0
R/W	—	—	—	—	—	—	R/W	R/W
POR	—	—	—	—	—	—	0	0

Bit 7~2 Unimplemented, read as “0”

Bit 1~0 **EEAH1~EEAH0**: Data EEPROM high byte address bit 1 ~ bit 0

• EED Register

Bit	7	6	5	4	3	2	1	0
Name	D7	D6	D5	D4	D3	D2	D1	D0
R/W	R/W	R/W	R/W	R/W	R/W	R/W	R/W	R/W
POR	0	0	0	0	0	0	0	0

Bit 7~0 **D7~D0**: Data EEPROM data bit 7 ~ bit 0

• EEC Register

Bit	7	6	5	4	3	2	1	0
Name	EWERTS	EREN	ER	MODE	WREN	WR	RDEN	RD
R/W	R/W	R/W	R/W	R/W	R/W	R/W	R/W	R/W
POR	0	0	0	0	0	0	0	0

Bit 7 **EWERTS**: EEPROM Erase time and Write time select
 0: Erase time is 3.2ms (t_{EEER}) / Write time is 2.2ms (t_{EEWR})
 1: Erase time is 3.7ms (t_{EEER}) / Write time is 3.0ms (t_{EEWR})

Bit 6 **EREN**: Data EEPROM erase enable
 0: Disable
 1: Enable

This bit is used to enable data EEPROM erase function and must be set high before erase operations are carried out. This bit will be automatically reset to zero by the hardware after the erase cycle has finished. Clearing this bit to zero will inhibit data EEPROM erase operations.

Bit 5 **ER**: EEPROM erase control
 0: Erase cycle has finished
 1: Activate an erase cycle

When this bit is set high by the application program, an erase cycle will be activated. This bit will be automatically reset to zero by the hardware after the erase cycle has finished. Setting this bit high will have no effect if the EREN has not first been set high.

Bit 4 **MODE**: EEPROM Operation mode select
 0: Byte operation mode
 1: Page operation mode

This is the EEPROM Page operation mode select bit and when set high by the application program will select the Page write or erase or read function. Otherwise, the EEPROM is the byte write or read function. The EEPROM page buffer size is 16-byte.

- Bit 3 **WREN**: Data EEPROM write enable
 0: Disable
 1: Enable
 This is the Data EEPROM Write Enable Bit which must be set high before Data EEPROM write operations are carried out. Clearing this bit to zero will inhibit Data EEPROM write operations. Note that this bit will automatically be reset to zero by hardware after the write cycle has finished.
- Bit 2 **WR**: EEPROM write control
 0: Write cycle has finished
 1: Activate a write cycle
 This is the Data EEPROM Write Control Bit and when set high by the application program will activate a write cycle. This bit will be automatically reset to zero by the hardware after the write cycle has finished. Setting this bit high will have no effect if the WREN has not first been set high.
- Bit 1 **RDEN**: Data EEPROM read enable
 0: Disable
 1: Enable
 This is the Data EEPROM Read Enable Bit which must be set high before Data EEPROM read operations are carried out. Clearing this bit to zero will inhibit Data EEPROM read operations.
- Bit 0 **RD**: EEPROM read control
 0: Read cycle has finished
 1: Activate a read cycle
 This is the Data EEPROM Read Control Bit and when set high by the application program will activate a read cycle. This bit will be automatically reset to zero by the hardware after the read cycle has finished. Setting this bit high will have no effect if the RDEN bit has not first been set high.

- Note: 1. The EREN, ER, WREN, WR, RDEN and RD cannot be set high at the same time in one instruction.
 2. Ensure that the f_{SUB} clock is stable before executing the erase/write operation.
 3. Ensure that the erase/write operation is totally complete before changing the EEC registers content.

Reading Operation from the EEPROM

Reading data from the EEPROM can be implemented by two modes for this device, byte read mode or page read mode, which is controlled by the EEPROM operation mode selection bit, MODE, in the EEC register.

Byte Read Mode

The EEPROM byte read operation can be executed when the mode selection bit, MODE, is cleared to zero. For a byte read operation the desired EEPROM address should first be placed in the EEAH and EEAL registers, as well as the read enable bit, RDEN, in the EEC register should be set high to enable the read function. Then setting the RD bit high will initiate the EEPROM byte read operation. Note that setting the RD bit high only will not initiate a read operation if the RDEN bit is not set high. When the read cycle terminates, the RD bit will automatically be cleared to zero and the EEPROM data can be read from the EED register. The data will remain in the EED register until another read or write operation is executed. The application program can poll the RD bit to determine when the data is valid for reading.

Page Read Mode

The EEPROM page read operation can be executed when the mode selection bit, MODE, is set high. The page size can be up to 16 bytes for the page read operation. For a page read operation the start address of the desired EEPROM page should first be placed in the EEAH and EEAL registers, as

well as the read enable bit, RDEN, in the EEC register should be set high to enable the read function. Then setting the RD bit high will initiate the EEPROM page read operation. Note that setting the RD bit high only will not initiate a read operation if the RDEN bit is not set high. When the current byte read cycle terminates, the RD bit will automatically be cleared indicating that the EEPROM data can be read from the EED register and the current address will be incremented by one by hardware. After this the RD bit will automatically be cleared to zero. The data which is stored in the next EEPROM address can continuously be read when the RD bit is again set high without reconfiguring the EEPROM address and RDEN control bit. The application program can poll the RD bit to determine when the data is valid for reading.

The EEPROM address higher 6 bits are used to specify the desired page location while the lower 4 bits are used to point to the actual address. In the page read operation mode the lower 4-bit address value will automatically be incremented by one. However, the higher 6-bit address value will not be incremented by hardware. When the EEPROM address lower 4-bit value which is internally incremented by one in the page mode reaches the page boundary, known as 0FH, the EEPROM address lower 4-bit value will stop at 0FH. The EEPROM address will not “roll over”.

Page Erase Operation to the EEPROM

The EEPROM page erase operation can be executed when the mode selection bit, MODE, is set high. The EEPROM is capable of a 16-byte page erase. The internal page buffer will be cleared by hardware after power on reset. When the EEPROM erase enable control bit, namely EREN, is changed from “1” to “0”, the internal page buffer will also be cleared. Note that when the EREN bit is changed from “0” to “1”, the internal page buffer will not be cleared. The EEPROM address higher 6 bits are used to specify the desired page location while the lower 4 bits are used to point to the actual address. In the page erase operation mode the lower 4-bit address value will automatically be incremented by one after each dummy data byte is written into the EED register. However, the higher 6-bit address value will not be incremented by hardware. When the EEPROM address lower 4-bit value which is internally incremented by one in the page mode reaches the page boundary, known as 0FH, the EEPROM address lower 4-bit value will stop at 0FH. The EEPROM address will not “roll over”.

For page erase operations the start address of the desired EEPROM page should first be placed in the EEAH and EEAL registers and the dummy data to be written should be placed in the EED register. The maximum data length for a page is 16 bytes. Note that the write operation to the EED register is used to tag address, it must be implemented to determine which addresses to be erased. When the page dummy data is completely written, then the EREN bit in the EEC register should be set high to enable erase operations and the ER bit must be immediately set high to initiate the EEPROM erase process. These two instructions must be executed in two consecutive instruction cycles to activate an erase operation successfully. The global interrupt enable bit EMI should also first be cleared before implementing an erase operation and then set again after a valid erase activation procedure has completed.

As the EEPROM erase cycle is controlled using an internal timer whose operation is asynchronous to microcontroller system clock, a certain time will elapse before the data will have been erased from the EEPROM. Detecting when the erase cycle has finished can be implemented either by polling the ER bit in the EEC register or by using the EEPROM interrupt. When the erase cycle terminates, the ER bit will be automatically cleared to zero by the microcontroller, informing the user that the page data has been erased. The application program can therefore poll the ER bit to determine when the erase cycle has ended. After the erase operation is finished, the EREN bit will be set low by hardware. The Data EEPROM erased page content will all be zero after a page erase operation.

Write Operation to the EEPROM

Writing data to the EEPROM can be implemented by two modes for this device, byte write mode or page write mode, which is controlled by the EEPROM operation mode selection bit, MODE, in the EEC register.

Byte Write Mode

The EEPROM byte write operation can be executed when the mode selection bit, MODE, is cleared to zero. For byte write operations the desired EEPROM address should first be placed in the EEAH and EEAL registers and the data to be written should be placed in the EED register. To write data to the EEPROM, the write enable bit, WREN, in the EEC register must first be set high to enable the write function. After this, the WR bit in the EEC register must be immediately set high to initiate a write cycle. These two instructions must be executed in two consecutive instruction cycles to activate a write operation successfully. The global interrupt bit EMI should also first be cleared before implementing any write operations, and then set high again after a valid write activation procedure has completed. Note that setting the WR bit high only will not initiate a write cycle if the WREN bit is not set.

As the EEPROM write cycle is controlled using an internal timer whose operation is asynchronous to microcontroller system clock, a certain time will elapse before the data will have been written into the EEPROM. Detecting when the write cycle has finished can be implemented either by polling the WR bit in the EEC register or by using the EEPROM interrupt. When the write cycle terminates, the WR bit will be automatically cleared to zero by the microcontroller, informing the user that the data has been written to the EEPROM. The application program can therefore poll the WR bit to determine when the write cycle has ended. After the write operation is finished, the WREN bit will be set low by hardware. Note that a byte erase operation will automatically be executed before a byte write operation is successfully activated.

Page Write Mode

Before a page write operation is executed, it is important to ensure that a relevant page erase operation has been successfully executed. The EEPROM page write operation can be executed when the mode selection bit, MODE, is set high. The EEPROM is capable of a 16-byte page write. The internal page buffer will be cleared by hardware after power on reset. When the EEPROM write enable control bit, namely WREN, is changed from “1” to “0”, the internal page buffer will also be cleared. Note that when the WREN bit is changed from “0” to “1”, the internal page buffer will not be cleared. A page write is initiated in the same way as a byte write initiation except that the EEPROM data can be written up to 16 bytes. The EEPROM address higher 6 bits are used to specify the desired page location while the lower 4 bits are used to point to the actual address. In the page write operation mode the lower 4-bit address value will automatically be incremented by one after each data byte is written into the EED register. However, the higher 6-bit address value will not be incremented by hardware. When the EEPROM address lower 4-bit value which is internally incremented by one in the page mode reaches the page boundary, known as 0FH, the EEPROM address lower 4-bit value will stop at 0FH. The EEPROM address will not “roll over”. At this point any data write operations to the EED register will be invalid.

For page write operations the start address of the desired EEPROM page should first be placed in the EEAH and EEAL registers and the data to be written should be placed in the EED register. The maximum data length for a page is 16 bytes. Note that when a data byte is written into the EED register, then the data in the EED register will be loaded into the internal page buffer and the current address value will automatically be incremented by one. When the page data is completely written into the page buffer, then the WREN bit in the EEC register should be set high to enable write

operations and the WR bit must be immediately set high to initiate the EEPROM write process. These two instructions must be executed in two consecutive instruction cycles to activate a write operation successfully. The global interrupt enable bit EMI should also first be cleared before implementing any write operations, and then set high again after a valid write activation procedure has completed. Note that setting the WR bit high only will not initiate a write cycle if the WREN bit is not set.

As the EEPROM write cycle is controlled using an internal timer whose operation is asynchronous to microcontroller system clock, a certain time will elapse before the data will have been written into the EEPROM. Detecting when the write cycle has finished can be implemented either by polling the WR bit in the EEC register or by using the EEPROM interrupt. When the write cycle terminates, the WR bit will be automatically cleared to zero by the microcontroller, informing the user that the data has been written to the EEPROM. The application program can therefore poll the WR bit to determine when the write cycle has ended. After the write operation is finished, the WREN bit will be set low by hardware.

Write Protection

Protection against inadvertent write operation is provided in several ways. After the device is powered-on the Write Enable bit in the control register will be cleared preventing any write operations. Also at power-on the Memory Pointer high byte register, MP1H or MP2H, will be reset to zero, which means that Data Memory Sector 0 will be selected. As the EEPROM control register is located in Sector 1, this adds a further measure of protection against spurious write operations. During normal program operation, ensuring that the Write Enable bit in the control register is cleared will safeguard against incorrect write operations.

EEPROM Interrupt

The EEPROM write interrupt is generated when an EEPROM erase or write cycle has ended. The EEPROM interrupt must first be enabled by setting the DEE bit in the relevant interrupt register. However as the EEPROM is contained within a Multi-function Interrupt, the associated multi-function interrupt enable bit must also be set. When an EEPROM erase or write cycle ends, the DEF request flag and its associated multi-function interrupt request flag will both be set. If the global, EEPROM and Multi-function interrupts are enabled and the stack is not full, a jump to the associated Multi-function Interrupt vector will take place. When the interrupt is serviced only the Multi-function interrupt flag will be automatically reset, the EEPROM interrupt flag must be manually reset by the application program. More details can be obtained in the Interrupt section.

Programming Considerations

Care must be taken that data is not inadvertently written to the EEPROM. Protection can be enhanced by ensuring that the Write Enable bit is normally cleared to zero when not writing. Also the Memory Pointer high byte register, MP1H or MP2H, could be normally cleared to zero as this would inhibit access to Sector 1 where the EEPROM control register exists. Although certainly not necessary, consideration might be given in the application program to the checking of the validity of new write data by a simple read back process.

When writing data the WR bit must be set high immediately after the WREN bit has been set high, to ensure the write cycle executes correctly. The global interrupt bit EMI should also be cleared before a write or erase cycle is executed and then set again after a valid write or erase activation procedure has completed. Note that the device should not enter the IDLE or SLEEP mode until the EEPROM read or write operation is totally complete. Otherwise, the EEPROM read or write operation will fail.

Programming Examples

Reading a Data Byte from the EEPROM – polling method

```
MOV A, 040H           ; setup memory pointer low byte MP1L
MOV MP1L, A           ; MP1 points to EEC register
MOV A, 01H            ; setup memory pointer high byte MP1H
MOV MP1H, A
CLR IAR1.4            ; clear MODE bit, select byte operation mode
MOV A, EEPROM_ADRES_H ; user defined high byte address
MOV EEAH, A
MOV A, EEPROM_ADRES_L ; user defined low byte address
MOV EEAL, A
SET IAR1.1            ; set RDEN bit, enable read operations
SET IAR1.0            ; start Read Cycle - set RD bit
BACK:
SZ IAR1.0             ; check for read cycle end
JMP BACK
CLR IAR1              ; disable EEPROM read function
CLR MP1H
MOV A, EED            ; move read data to register
MOV READ_DATA, A
```

Reading a Data Page from the EEPROM – polling method

```
MOV A, EEPROM_ADRES_H ; user defined high byte address
MOV EEAH, A
MOV A, EEPROM_ADRES_L ; user defined low byte address
MOV EEAL, A
MOV A, 040H           ; setup memory pointer low byte MP1L
MOV MP1L, A           ; MP1 points to EEC register
MOV A, 01H            ; setup memory pointer high byte MP1H
MOV MP1H, A
SET IAR1.4            ; set MODE bit, select page operation mode
SET IAR1.1            ; set RDEN bit, enable read operations
; ~~~~ The data length can be up to 16 bytes (Start) ~~~~
CALL READ
CALL READ
:
:
JMP PAGE_READ_FINISH
; ~~~~ The data length can be up to 16 bytes (End) ~~~~
READ:
SET IAR1.0            ; start Read Cycle - set RD bit
BACK:
SZ IAR1.0             ; check for read cycle end
JMP BACK
MOV A, EED            ; move read data to register
MOV READ_DATA, A
RET
:
PAGE_READ_FINISH:
CLR IAR1              ; disable EEPROM read function
CLR MP1H
```

Erasing a Data Page to the EEPROM – polling method

```

MOV A, 040H           ; setup memory pointer low byte MP1L
MOV MP1L, A          ; MP1 points to EEC register
MOV A, 01H           ; setup memory pointer high byte MP1H
MOV MP1H, A
SET IAR1.4           ; set MODE bit, select page operation mode
MOV A, EEPROM_ADRES_H ; user defined high byte address
MOV EEAH, A
MOV A, EEPROM_ADRES_L ; user defined low byte address
MOV EEAL, A
; ~~~~ The data length can be up to 16 bytes (Start) ~~~~
CALL WRITE_BUF
CALL WRITE_BUF
:
:
JMP Erase_START
; ~~~~ The data length can be up to 16 bytes (End) ~~~~
WRITE_BUF:
MOV A, EEPROM_DATA   ; user defined data, erase mode don't care data value
MOV EED, A
RET
:
Erase_START:
CLR EMI
SET IAR1.6           ; set EREN bit, enable erase operations
SET IAR1.5           ; start Erase Cycle - set ER bit - executed immediately
; after setting EREN bit

SET EMI
BACK:
SZ IAR1.5           ; check for erase cycle end
JMP BACK
CLR MP1H

```

Writing a Data Byte to the EEPROM – polling method

```

MOV A, 040H           ; setup memory pointer low byte MP1L
MOV MP1L, A          ; MP1 points to EEC register
MOV A, 01H           ; setup memory pointer high byte MP1H
MOV MP1H, A
CLR IAR1.4           ; clear MODE bit, select byte operation mode
MOV A, EEPROM_ADRES_H ; user defined high byte address
MOV EEAH, A
MOV A, EEPROM_ADRES_L ; user defined low byte address
MOV EEAL, A
MOV A, EEPROM_DATA   ; user defined data
MOV EED, A
CLR EMI
SET IAR1.3           ; set WREN bit, enable write operations
SET IAR1.2           ; start Write Cycle - set WR bit - executed immediately
; after setting WREN bit

SET EMI
BACK:
SZ IAR1.2           ; check for write cycle end
JMP BACK
CLR MP1H

```

Writing a Data Page to the EEPROM – polling method

```

MOV A, 040H           ; setup memory pointer low byte MP1L
MOV MP1L, A          ; MP1 points to EEC register
MOV A, 01H           ; setup memory pointer high byte MP1H
MOV MP1H, A
SET IAR1.4           ; set MODE bit, select page operation mode
MOV A, EEPROM_ADRES_H ; user defined high byte address
MOV EEAH, A
MOV A, EEPROM_ADRES_L ; user defined low byte address
MOV EEAL, A
; ~~~~ The data length can be up to 16 bytes (Start) ~~~~
CALL WRITE_BUF
CALL WRITE_BUF
:
:
JMP WRITE_START
; ~~~~ The data length can be up to 16 bytes (End) ~~~~
WRITE_BUF:
MOV A, EEPROM_DATA   ; user defined data
MOV EED, A
RET
:
WRITE_START:
CLR EMI
SET IAR1.3           ; set WREN bit, enable write operations
SET IAR1.2           ; start Write Cycle - set WR bit - executed immediately
; after setting WREN bit

SET EMI
BACK:
SZ IAR1.2            ; check for write cycle end
JMP BACK
CLR MP1H
    
```

Oscillators

Various oscillator options offer the user a wide range of functions according to their various application requirements. The flexible features of the oscillator functions ensure that the best optimization can be achieved in terms of speed and power saving. Oscillator selections and operation are selected through a combination of configuration options and relevant control registers.

Oscillator Overview

In addition to being the source of the main system clock the oscillators also provide clock sources for the Watchdog Timer and Time Base Interrupts. External oscillators requiring some external components as well as fully integrated internal oscillators requiring no external components are provided to form a wide range of both fast and slow system oscillators. The higher frequency oscillators provide higher performance but carry with it the disadvantage of higher power requirements, while the opposite is of course true for the lower frequency oscillators. With the capability of dynamically switching between fast and slow system clock, the device have the flexibility to optimize the performance/power ratio, a feature especially important in power sensitive portable applications.

Type	Name	Frequency	Pins
Internal High Speed RC	HIRC	8/12/16MHz	—
External High Speed Crystal	HXT	400kHz~16MHz	OSC1/OSC2
Internal Low Speed RC	LIRC	32kHz	—
External Low Speed Crystal	LXT	32.768kHz	XT1/XT2

Oscillator Types

System Clock Configurations

There are four methods of generating the system clock, two high speed oscillators and two low speed oscillators. The high speed oscillator is the internal 8/12/16MHz RC oscillator, HIRC, and the external crystal/ceramic oscillator, HXT. The low speed oscillators are the internal 32kHz RC oscillator, LIRC, and the external 32.768kHz crystal oscillator, LXT. Selecting whether the low or high speed oscillator is used as the system oscillator is implemented using the CKS2~CKS0 bits in the SCC register and as the system clock can be dynamically selected.

The actual source clock used for the low speed oscillator is chosen via the FSS bit in the SCC register. The frequency of the slow speed or high speed system clock is determined using the CKS2~CKS0 bits in the SCC register. Note that two oscillator selections must be made namely one high speed and one low speed system oscillators.

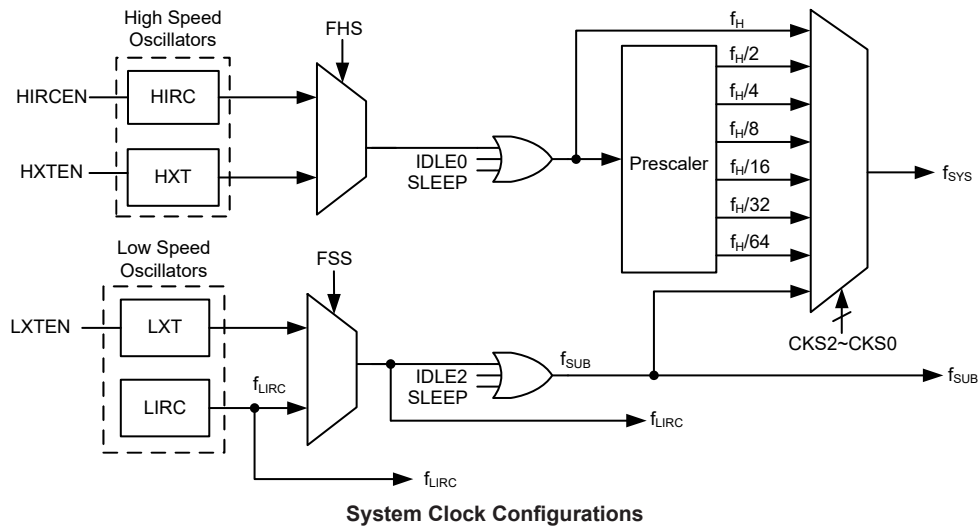

External Crystal/Ceramic Oscillator – HXT

The External Crystal/Ceramic System Oscillator is the high frequency oscillator. For most crystal oscillator configurations, the simple connection of a crystal across OSC1 and OSC2 will create the necessary phase shift and feedback for oscillation, without requiring external capacitors. However, for some crystal types and frequencies, to ensure oscillation, it may be necessary to add two small value capacitors, C1 and C2. Using a ceramic resonator will usually require two small value capacitors, C1 and C2, to be connected as shown for oscillation to occur. The values of C1 and C2 should be selected in consultation with the crystal or resonator manufacturer’s specification.

For oscillator stability and to minimise the effects of noise and crosstalk, it is important to ensure that the crystal and any associated resistors and capacitors along with interconnecting lines are all located as close to the MCU as possible.

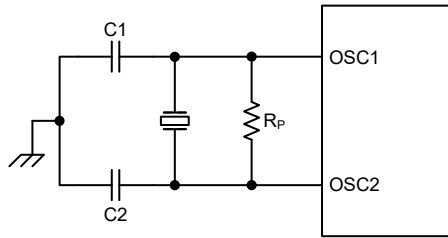

Note: 1. R_p is normally not required. C1 and C2 are required.
 2. Although not shown OSC1/OSC2 pins have a parasitic capacitance of around 7pF.

Crystal/Resonator Oscillator – HXT

HXT Oscillator C1 and C2 Values		
Crystal Frequency	C1	C2
16MHz	0 pF	0 pF
12MHz	0 pF	0 pF
8MHz	0 pF	0 pF
4MHz	0 pF	0 pF
1MHz	100 pF	100 pF

Note: C1 and C2 values are for guidance only.

Crystal Recommended Capacitor Values

Internal High Speed RC Oscillator – HIRC

The internal RC oscillator is a fully integrated system oscillator requiring no external components. The internal RC oscillator has three fixed frequencies of 8MHz, 12MHz and 16MHz, which are selected by the HIRCS1~HIRCS0 bits in the HIRCC register. These bits must also be setup to match the selected configuration option frequency to ensure that the HIRC frequency accuracy specified in the A.C. Characteristics is achieved. Device trimming during the manufacturing process and the inclusion of internal frequency compensation circuits are used to ensure that the influence of the power supply voltage, temperature and process variations on the oscillation frequency are minimised.

External 32.768kHz Crystal Oscillator – LXT

The external 32.768kHz crystal system oscillator is one of the low frequency oscillator choices, which is selected via a software control bit, FSS. This clock source has a fixed frequency of 32.768kHz and requires a 32.768kHz crystal to be connected between pins XT1 and XT2. The external resistor and capacitor components connected to the 32.768kHz crystal are necessary to provide oscillation. For applications where precise frequencies are essential, these components may be required to provide frequency compensation due to different crystal manufacturing tolerances. After the LXT oscillator is enabled by setting the LXTEN bit to 1, there is a time delay associated with the LXT oscillator waiting for it to start-up.

When the microcontroller enters the SLEEP or IDLE Mode, the system clock is switched off to stop microcontroller activity and to conserve power. However, in many microcontroller applications it may be necessary to keep the internal timers operational even when the microcontroller is in the SLEEP or IDLE Mode. To do this, another clock, independent of the system clock, must be provided.

However, for some crystals, to ensure oscillation and accurate frequency generation, it is necessary to add two small value external capacitors, C1 and C2. The exact values of C1 and C2 should be selected in consultation with the crystal or resonator manufacturer’s specification. The external parallel feedback resistor, R_p, is required.

The pin-shared software control bits determine if the XT1/XT2 pins are used for the LXT oscillator or as I/O or other pin-shared functional pins.

- If the LXT oscillator is not used for any clock source, the XT1/XT2 pins can be used as normal I/O or other pin-shared functional pins.
- If the LXT oscillator is used for any clock source, the 32.768kHz crystal should be connected to the XT1/XT2 pins.

For oscillator stability and to minimise the effects of noise and crosstalk, it is important to ensure that the crystal and any associated resistors and capacitors along with interconnecting lines are all located as close to the MCU as possible.

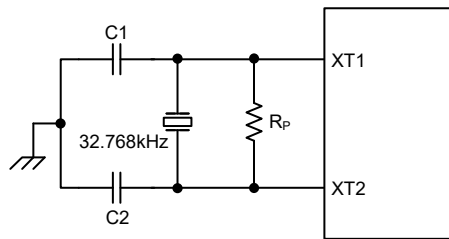

- Note: 1. R_p, C1 and C2 are required.
2. Although not shown XT1/XT2 pins have a parasitic capacitance of around 7pF.

External LXT Oscillator

LXT Oscillator C1 and C2 Values		
Crystal Frequency	C1	C2
32.768kHz	10pF	10pF
Note: 1. C1 and C2 values are for guidance only. 2. R _p =5MΩ~10MΩ is recommended.		

32.768kHz Crystal Recommended Capacitor Values

Internal 32kHz Oscillator – LIRC

The Internal 32kHz System Oscillator is a fully integrated RC oscillator with a typical frequency of 32kHz, requiring no external components for its implementation. Device trimming during the manufacturing process and the inclusion of internal frequency compensation circuits are used to ensure that the influence of the power supply voltage, temperature and process variations on the oscillation frequency are minimised.

Operating Modes and System Clocks

Present day applications require that their microcontrollers have high performance but often still demand that they consume as little power as possible, conflicting requirements that are especially true in battery powered portable applications. The fast clocks required for high performance will by their nature increase current consumption and of course vice versa, lower speed clocks reduce current consumption. As both high and low speed clock sources are provided the means to switch between them dynamically, the user can optimise the operation of their microcontroller to achieve the best performance/power ratio.

System Clocks

The device has different clock sources for both the CPU and peripheral function operation. By providing the user with a wide range of clock selections using register programming, a clock system can be configured to obtain maximum application performance.

The main system clock, can come from either a high frequency, f_H , or low frequency, f_{SUB} , source, and is selected using the CKS2~CKS0 bits in the SCC register. The high speed system clock is sourced from an HXT or HIRC oscillator, selected via configuring the FHS bit in the SCC register. The low speed system clock source can be sourced from the internal clock f_{SUB} . If f_{SUB} is selected then it can be sourced from the LXT or LIRC oscillator, selected via configuring the FSS bit in the SCC register. The other choice, which is a divided version of the high speed system oscillator has a range of $f_H/2 \sim f_H/64$.

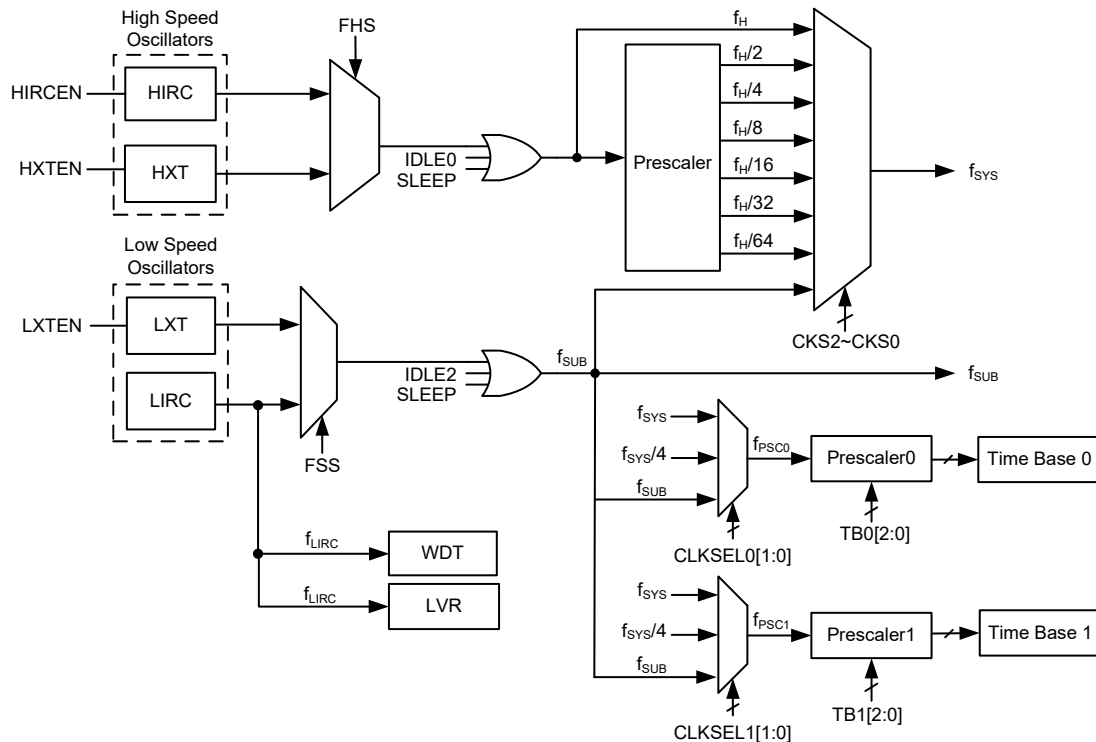

Device Clock Configurations

Note: When the system clock source f_{SYS} is switched to f_{SUB} from f_H , the high speed oscillator can be stopped to conserve the power or continue to oscillate to provide the clock source, $f_H \sim f_H/64$, for peripheral circuit to use, which is determined by configuring the corresponding high speed oscillator enable control bit.

System Operation Modes

There are six different modes of operation for the microcontroller, each one with its own special characteristics and which can be chosen according to the specific performance and power requirements of the application. There are two modes allowing normal operation of the microcontroller, the FAST Mode and SLOW Mode. The remaining four modes, the SLEEP, IDLE0, IDLE1 and IDLE2 Mode are used when the microcontroller CPU is switched off to conserve power.

Operation Mode	CPU	Register Setting			f _{sys}	f _H	f _{SUB}	f _{LIRC}
		FHIDEN	FSIDEN	CKS2~CKS0				
FAST	On	x	x	000~110	f _H ~f _H /64	On	On	On
SLOW	On	x	x	111	f _{SUB}	On/Off ⁽¹⁾	On	On
IDLE0	Off	0	1	000~110	Off	Off	On	On
				111	On			
IDLE1	Off	1	1	xxx	On	On	On	On
IDLE2	Off	1	0	000~110	On	On	Off	On
				111	Off			
SLEEP	Off	0	0	xxx	Off	Off	Off	On/Off ⁽²⁾

"x": Don't care

Note: 1. The f_H clock will be switched on or off by configuring the corresponding oscillator enable bit in the SLOW mode.

2. The f_{LIRC} clock can be switched on or off which is controlled by the WDT function being enabled or disabled in the SLEEP mode.

FAST Mode

This is one of the main operating modes where the microcontroller has all of its functions operational and where the system clock is provided by one of the high speed oscillators. This mode operates allowing the microcontroller to operate normally with a clock source will come from one of the high speed oscillators, either the HXT or HIRC oscillator. The high speed oscillator will however first be divided by a ratio ranging from 1 to 64, the actual ratio being selected by the CKS2~CKS0 bits in the SCC register. Although a high speed oscillator is used, running the microcontroller at a divided clock ratio reduces the operating current.

SLOW Mode

This is also a mode where the microcontroller operates normally although now with a slower speed clock source. The clock source used will be from f_{SUB}. The f_{SUB} clock is derived from the LXT or LIRC oscillator.

SLEEP Mode

The SLEEP Mode is entered when a HALT instruction is executed and when the FHIDEN and FSIDEN bit are low. In the SLEEP mode the CPU will be stopped and both the high and low speed oscillators will be switched off. However the f_{LIRC} clock can still continue to operate if the WDT function is enabled by the WDTC register.

IDLE0 Mode

The IDLE0 Mode is entered when a HALT instruction is executed and when the FHIDEN bit in the SCC register is low and the FSIDEN bit in the SCC register is high. In the IDLE0 Mode the CPU will be switched off but the low speed oscillator will be turned on to drive some peripheral functions.

IDLE1 Mode

The IDLE1 Mode is entered when a HALT instruction is executed and when the FHIDEN bit in the SCC register is high and the FSIDEN bit in the SCC register is high. In the IDLE1 Mode the CPU will be switched off but both the high and low speed oscillators will be turned on to provide a clock source to keep some peripheral functions operational.

IDLE2 Mode

The IDLE2 Mode is entered when a HALT instruction is executed and when the FHIDEN bit in the SCC register is high and the FSIDEN bit in the SCC register is low. In the IDLE2 Mode the CPU will be switched off but the high speed oscillator will be turned on to provide a clock source to keep some peripheral functions operational.

Control Registers

The registers, SCC, HIRCC, HXTC and LXTC, are used to control the system clock and the corresponding oscillator configurations.

Register Name	Bit							
	7	6	5	4	3	2	1	0
SCC	CKS2	CKS1	CKS0	—	FHS	FSS	FHIDEN	FSIDEN
HIRCC	—	—	—	—	HIRC1	HIRC0	HIRCF	HIRCEN
HXTC	—	—	—	—	—	HXTM	HXTF	HXTEN
LXTC	—	—	—	—	—	—	LXTF	LXTEN

System Operating Mode Control Register List

• **SCC Register**

Bit	7	6	5	4	3	2	1	0
Name	CKS2	CKS1	CKS0	—	FHS	FSS	FHIDEN	FSIDEN
R/W	R/W	R/W	R/W	—	R/W	R/W	R/W	R/W
POR	0	0	0	—	0	0	0	0

Bit 7~5 **CKS2~CKS0:** System clock selection

- 000: f_H
- 001: $f_H/2$
- 010: $f_H/4$
- 011: $f_H/8$
- 100: $f_H/16$
- 101: $f_H/32$
- 110: $f_H/64$
- 111: f_{SUB}

These three bits are used to select which clock is used as the system clock source. In addition to the system clock source directly derived from f_H or f_{SUB} , a divided version of the high speed system oscillator can also be chosen as the system clock source.

Bit 4 Unimplemented, read as “0”

Bit 3 **FHS:** High frequency clock selection

- 0: HIRC
- 1: HXT

Bit 2 **FSS:** Low frequency clock selection

- 0: LIRC
- 1: LXT

- Bit 1 **FHIDEN**: High frequency oscillator control when CPU is switched off
 0: Disable
 1: Enable
 This bit is used to control whether the high speed oscillator is activated or stopped when the CPU is switched off by executing a “HALT” instruction.
- Bit 0 **FSIDEN**: Low frequency oscillator control when CPU is switched off
 0: Disable
 1: Enable
 This bit is used to control whether the low speed oscillator is activated or stopped when the CPU is switched off by executing a “HALT” instruction.

Note: A certain delay is required before the relevant clock is successfully switched to the target clock source after any clock switching setup using the CKS2~CKS0 bits. A proper delay time must be arranged before executing the following operations which require immediate reaction with the target clock source.

Clock switching delay time= $4 \times t_{SYS} + [0 \sim (1.5 \times t_{Curr.} + 0.5 \times t_{Tar.})]$, where $t_{Curr.}$ indicates the current clock period, $t_{Tar.}$ indicates the target clock period and t_{SYS} indicates the current system clock period.

• **HIRCC Register**

Bit	7	6	5	4	3	2	1	0
Name	—	—	—	—	HIRC1	HIRC0	HIRCF	HIRCEN
R/W	—	—	—	—	R/W	R/W	R	R/W
POR	—	—	—	—	0	0	0	1

- Bit 7~4 Unimplemented, read as “0”
- Bit 3~2 **HIRC1~HIRC0**: HIRC frequency selection
 00: 8MHz
 01: 12MHz
 10: 16MHz
 11: 8MHz
 When the HIRC oscillator is enabled or the HIRC frequency selection is changed by the application program, the clock frequency will automatically be changed after the HIRCF flag is set to 1.
 It is recommended that the HIRC frequency selected by these two bits should be the same with the frequency determined by the configuration options to achieve the HIRC frequency accuracy specified in the A.C. Characteristics.
- Bit 1 **HIRCF**: HIRC oscillator stable flag
 0: HIRC unstable
 1: HIRC stable
 This bit is used to indicate whether the HIRC oscillator is stable or not. When the HIRCEN bit is set to 1 to enable the HIRC oscillator or the HIRC frequency selection is changed by the application program, the HIRCF bit will first be cleared to 0 and then set to 1 after the HIRC oscillator is stable.
- Bit 0 **HIRCEN**: HIRC oscillator enable control
 0: Disable
 1: Enable

• **HXTC Register**

Bit	7	6	5	4	3	2	1	0
Name	—	—	—	—	—	HXTM	HXTF	HXTEN
R/W	—	—	—	—	—	R/W	R	R/W
POR	—	—	—	—	—	0	0	0

Bit 7~3 Unimplemented, read as “0”

Bit 2 **HXTM**: HXT mode selection
 0: HXT frequency \leq 10MHz
 1: HXT frequency > 10MHz

This bit is used to select the HXT oscillator operating mode. Note that this bit must be properly configured before the HXT is enabled. When the OSC1 and OSC2 pins are enabled and the HXTEN bit is set to 1 to enable the HXT oscillator, it is invalid to change the value of this bit. Otherwise, this bit value can be changed with no operation on the HXT function.

Bit 1 **HXTF**: HXT oscillator stable flag
 0: HXT unstable
 1: HXT stable

This bit is used to indicate whether the HXT oscillator is stable or not. When the HXTEN bit is set to 1 to enable the HXT oscillator, the HXTF bit will first be cleared to 0 and then set to 1 after the HXT oscillator is stable.

Bit 0 **HXTEN**: HXT oscillator enable control
 0: Disable
 1: Enable

• **LXTC Register**

Bit	7	6	5	4	3	2	1	0
Name	—	—	—	—	—	—	LXTF	LXTEN
R/W	—	—	—	—	—	—	R	R/W
POR	—	—	—	—	—	1	0	0

Bit 7~3 Unimplemented, read as “0”

Bit 2 Unimplemented, read as “1”

Bit 1 **LXTF**: LXT oscillator stable flag
 0: LXT unstable
 1: LXT stable

This bit is used to indicate whether the LXT oscillator is stable or not. When the LXTEN bit is set to 1 to enable the LXT oscillator, the LXTF bit will first be cleared to 0 and then set to 1 after the LXT oscillator is stable.

Bit 0 **LXTEN**: LXT oscillator enable control
 0: Disable
 1: Enable

Operating Mode Switching

The device can switch between operating modes dynamically allowing the user to select the best performance/power ratio for the present task in hand. In this way microcontroller operations that do not require high performance can be executed using slower clocks thus requiring less operating current and prolonging battery life in portable applications.

In simple terms, Mode Switching between the FAST Mode and SLOW Mode is executed using the CKS2~CKS0 bits in the SCC register while Mode Switching from the FAST/SLOW Modes to the SLEEP/IDLE Modes is executed via the HALT instruction. When a HALT instruction is executed, whether the device enters the IDLE Mode or the SLEEP Mode is determined by the condition of the FHIDEN and FSIDEN bits in the SCC register.

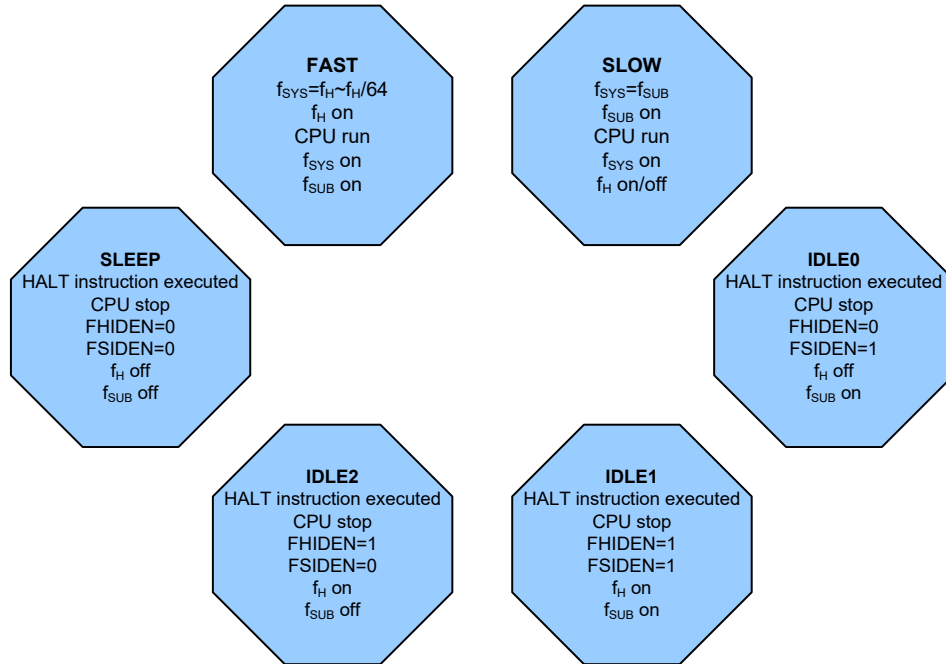

FAST Mode to SLOW Mode Switching

When running in the FAST Mode, which uses the high speed system oscillator, and therefore consumes more power, the system clock can switch to run in the SLOW Mode by setting the CKS2~CKS0 bits to “111” in the SCC register. This will then use the low speed system oscillator which will consume less power. Users may decide to do this for certain operations which do not require high performance and can subsequently reduce power consumption.

The SLOW Mode is sourced from the LXT or LIRC oscillator determined by the FSS bit in the SCC register and therefore requires these oscillators to be stable before full mode switching occurs.

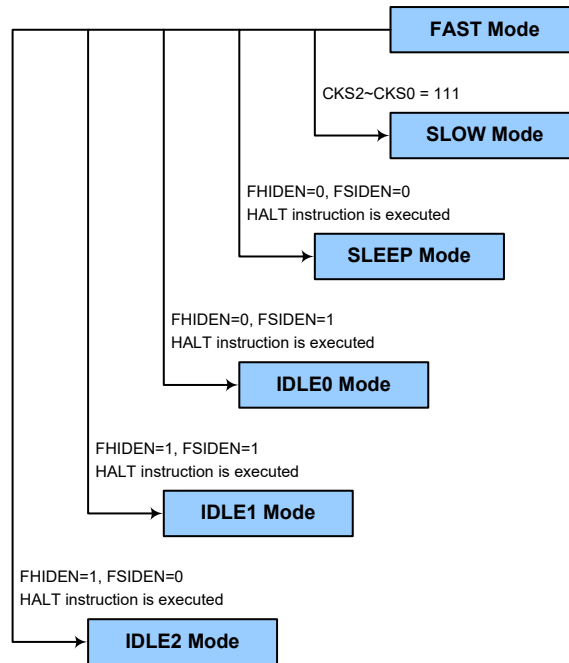

SLOW Mode to FAST Mode Switching

In SLOW mode the system clock is derived from f_{SUB} . When system clock is switched back to the FAST mode from f_{SUB} , the CKS2~CKS0 bits should be set to “000”~“110” and then the system clock will respectively be switched to $f_H \sim f_H/64$.

However, if f_H is not used in SLOW mode and thus switched off, it will take some time to re-oscillate and stabilise when switching to the FAST mode from the SLOW Mode. This is monitored using the HXTF bit in the HXTC register or the HIRCF bit in the HIRCC register. The time duration required for the high speed system oscillator stabilization is specified in the System Start Up Time Characteristics.

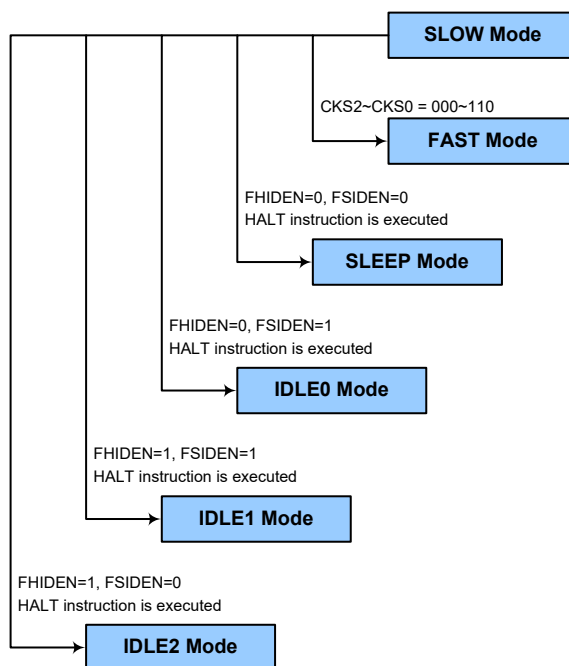

Entering the SLEEP Mode

There is only one way for the device to enter the SLEEP Mode and that is to execute the “HALT” instruction in the application program with both the FHIDEN and FSIDEN bits in the SCC register equal to “0”. In this mode all the clocks and functions will be switched off except the WDT function. When this instruction is executed under the conditions described above, the following will occur:

- The system clock will be stopped and the application program will stop at the “HALT” instruction.
- The Data Memory contents and registers will maintain their present condition.
- The I/O ports will maintain their present conditions.
- In the status register, the Power Down flag PDF will be set, and WDT timeout flag TO will be cleared.
- The WDT will be cleared and resume counting if the WDT function is enabled. If the WDT function is disabled, the WDT will be cleared and then stopped.

Entering the IDLE0 Mode

There is only one way for the device to enter the IDLE0 Mode and that is to execute the “HALT” instruction in the application program with the FHIDEN bit in the SCC register equal to “0” and the FSIDEN bit in the SCC register equal to “1”. When this instruction is executed under the conditions described above, the following will occur:

- The f_H clock will be stopped and the application program will stop at the “HALT” instruction, but the f_{SUB} clock will be on.
- The Data Memory contents and registers will maintain their present condition.
- The I/O ports will maintain their present conditions.
- In the status register, the Power Down flag PDF will be set, and WDT timeout flag TO will be cleared.
- The WDT will be cleared and resume counting if the WDT function is enabled. If the WDT function is disabled, the WDT will be cleared and then stopped.

Entering the IDLE1 Mode

There is only one way for the device to enter the IDLE1 Mode and that is to execute the “HALT” instruction in the application program with both the FHIDEN and FSIDEN bits in the SCC register equal to “1”. When this instruction is executed under the conditions described above, the following will occur:

- The f_H and f_{SUB} clocks will be on but the application program will stop at the “HALT” instruction.
- The Data Memory contents and registers will maintain their present condition.
- The I/O ports will maintain their present conditions.
- In the status register, the Power Down flag PDF will be set, and WDT timeout flag TO will be cleared.
- The WDT will be cleared and resume counting if the WDT function is enabled. If the WDT function is disabled, the WDT will be cleared and then stopped.

Entering the IDLE2 Mode

There is only one way for the device to enter the IDLE2 Mode and that is to execute the “HALT” instruction in the application program with the FHIDEN bit in the SCC register equal to “1” and the FSIDEN bit in the SCC register equal to “0”. When this instruction is executed under the conditions described above, the following will occur:

- The f_H clock will be on but the f_{SUB} clock will be off and the application program will stop at the “HALT” instruction.
- The Data Memory contents and registers will maintain their present condition.
- The I/O ports will maintain their present conditions.
- In the status register, the Power Down flag PDF will be set, and WDT timeout flag TO will be cleared.
- The WDT will be cleared and resume counting if the WDT function is enabled. If the WDT function is disabled, the WDT will be cleared and then stopped.

Standby Current Considerations

As the main reason for entering the SLEEP or IDLE Mode is to keep the current consumption of the device to as low a value as possible, perhaps only in the order of several micro-amps except in the IDLE1 and IDLE2 Mode, there are other considerations which must also be taken into account by the circuit designer if the power consumption is to be minimised. Special attention must be made to the I/O pins on the device. All high-impedance input pins must be connected to either a fixed high or low level as any floating input pins could create internal oscillations and result in increased current consumption. This also applies to device which has different package types, as there may be unbonded pins. These must either be setup as outputs or if setup as inputs must have pull-high resistors connected.

Care must also be taken with the loads, which are connected to I/O pins, which are setup as outputs. These should be placed in a condition in which minimum current is drawn or connected only to external circuits that do not draw current, such as other CMOS inputs. Also note that additional standby current will also be required if the LIRC or LXT oscillator has enabled.

In the IDLE1 and IDLE2 Mode the high speed oscillator is on, if the peripheral function clock source is derived from the high speed oscillator, the additional standby current will also be perhaps in the order of several hundred micro-amps.

Wake-up

To minimise power consumption the device can enter the SLEEP or any IDLE Mode, where the CPU will be switched off. However, when the device is woken up again, it will take a considerable time for the original system oscillator to restart, stabilise and allow normal operation to resume.

After the system enters the SLEEP or IDLE Mode, it can be woken up from one of various sources listed as follows:

- An external pin reset
- An external falling edge on Port A
- A system interrupt
- A WDT overflow

If the system is woken up by an external $\overline{\text{RES}}$ pin reset, the device will experience a full system reset, however, if the device is woken up by a WDT overflow, a Watchdog Timer reset will be initiated. Although both of these wake-up methods will initiate a reset operation, the actual source of the wake-up can be determined by examining the TO and PDF flags. The PDF flag is cleared by a system power-up or executing the clear Watchdog Timer instructions and is set when executing the “HALT” instruction. The TO flag is set if a WDT time-out occurs, and causes a wake-up that only resets the Program Counter and Stack Pointer, the other flags remain in their original status.

Each pin on Port A can be setup using the PAWU register to permit a negative transition on the pin to wake up the system. When a Port A pin wake-up occurs, the program will resume execution at the instruction following the “HALT” instruction. If the system is woken up by an interrupt, then two possible situations may occur. The first is where the related interrupt is disabled or the interrupt is enabled but the stack is full, in which case the program will resume execution at the instruction following the “HALT” instruction. In this situation, the interrupt which woke up the device will not be immediately serviced, but will rather be serviced later when the related interrupt is finally enabled or when a stack level becomes free. The other situation is where the related interrupt is enabled and the stack is not full, in which case the regular interrupt response takes place. If an interrupt request flag is set high before entering the SLEEP or IDLE Mode, the wake-up function of the related interrupt will be disabled.

Watchdog Timer

The Watchdog Timer is provided to prevent program malfunctions or sequences from jumping to unknown locations, due to certain uncontrollable external events such as electrical noise.

Watchdog Timer Clock Source

The Watchdog Timer clock source is provided by the internal clock, f_{LIRC} . The LIRC internal oscillator has an approximate frequency of 32kHz and this specified internal clock period can vary with V_{DD} , temperature and process variations. The Watchdog Timer source clock is then subdivided by a ratio of 2^8 to 2^{18} to give longer timeouts, the actual value being chosen using the WS2~WS0 bits in the WDTC register.

Watchdog Timer Control Register

A single register, WDTC, controls the required timeout period as well as the enable/disable and reset MCU operation.

• WDTC Register

Bit	7	6	5	4	3	2	1	0
Name	WE4	WE3	WE2	WE1	WE0	WS2	WS1	WS0
R/W	R/W	R/W	R/W	R/W	R/W	R/W	R/W	R/W
POR	0	1	0	1	0	0	1	1

Bit 7~3 **WE4~WE0**: WDT function software control

10101: Disable
 01010: Enable
 Others: Reset MCU

When these bits are changed by the environmental noise or software setting to reset the microcontroller, the reset operation will be activated after a delay time, t_{SRESET} , and the WRF bit in the RSTFC register will be set high.

Bit 2~0 **WS2~WS0**: WDT time-out period selection

000: $2^8/f_{LIRC}$
 001: $2^{10}/f_{LIRC}$
 010: $2^{12}/f_{LIRC}$
 011: $2^{14}/f_{LIRC}$
 100: $2^{15}/f_{LIRC}$
 101: $2^{16}/f_{LIRC}$
 110: $2^{17}/f_{LIRC}$
 111: $2^{18}/f_{LIRC}$

These three bits determine the division ratio of the watchdog timer source clock, which in turn determines the time-out period.

• RSTFC Register

Bit	7	6	5	4	3	2	1	0
Name	—	—	—	—	RSTF	LVRF	LRF	WRF
R/W	—	—	—	—	R/W	R/W	R/W	R/W
POR	—	—	—	—	0	x	0	0

“x”: Unknown

Bit 7~4 Unimplemented, read as “0”

Bit 3 **RSTF**: Reset control register software reset flag
 Refer to the “Internal Reset Control” section

Bit 2 **LVRF**: LVR function reset flag
 Refer to the “Low Voltage Reset” section

- Bit 1 **LRF:** LVR control register software reset flag
Refer to the “Low Voltage Reset” section
- Bit 0 **WRF:** WDT control register software reset flag
0: Not occur
1: Occurred

This bit is set high by the WDT control register software reset and cleared by the application program. Note that this bit can only be cleared to zero by the application program.

Watchdog Timer Operation

The Watchdog Timer operates by providing a device reset when its timer overflows. This means that in the application program and during normal operation the user has to strategically clear the Watchdog Timer before it overflows to prevent the Watchdog Timer from executing a reset. This is done using the clear watchdog instruction. If the program malfunctions for whatever reason, jumps to an unknown location, or enters an endless loop, this clear instruction will not be executed in the correct manner, in which case the Watchdog Timer will overflow and reset the device. There are five bits, WE4~WE0, in the WDTC register to offer the enable/disable control and reset control of the Watchdog Timer. The WDT function will be disabled when the WE4~WE0 bits are set to a value of 10101B while the WDT function will be enabled if the WE4~WE0 bits are equal to 01010B. If the WE4~WE0 bits are set to any other values, other than 01010B and 10101B, it will reset the device after a delay time, t_{SRESET} . After power on these bits will have a value of 01010B.

WE4 ~ WE0 Bits	WDT Function
10101B	Disable
01010B	Enable
Any other values	Reset MCU

Watchdog Timer Function Control

Under normal program operation, a Watchdog Timer time-out will initialise a device reset and set the status bit TO. However, if the system is in the SLEEP or IDLE Mode, when a Watchdog Timer time-out occurs, the TO bit in the status register will be set and only the Program Counter and Stack Pointer will be reset. Four methods can be adopted to clear the contents of the Watchdog Timer. The first is a WDT software reset, which means a certain value except 01010B and 10101B written into the WE4~WE0 bit filed, the second is using the Watchdog Timer software clear instruction and the third is via a HALT instruction. The last is an external hardware reset, which means a low level on the external reset pin if the external reset pin is selected by the RSTC register.

There is only one method of using software instruction to clear the Watchdog Timer. That is to use the single “CLR WDT” instruction to clear the WDT.

The maximum time out period is when the 2^{18} division ratio is selected. As an example, with a 32kHz LIRC oscillator as its source clock, this will give a maximum watchdog period of around 8 seconds for the 2^{18} division ratio, and a minimum timeout of 8ms for the 2^8 division ratio.

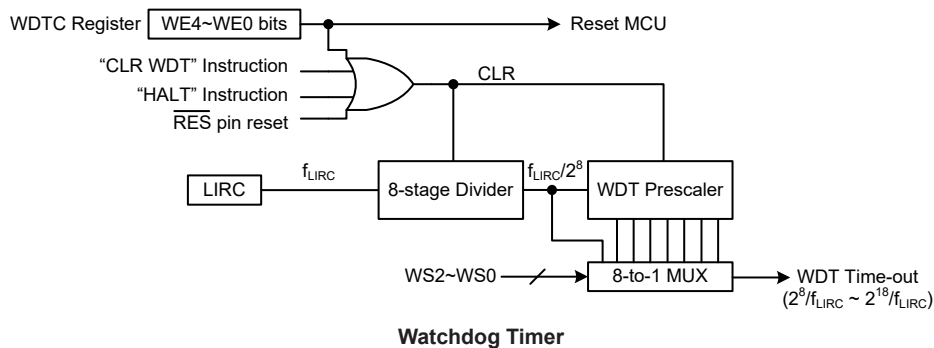

Reset and Initialisation

A reset function is a fundamental part of any microcontroller ensuring that the device can be set to some predetermined condition irrespective of outside parameters. The most important reset condition is after power is first applied to the microcontroller. In this case, internal circuitry will ensure that the microcontroller, after a short delay, will be in a well-defined state and ready to execute the first program instruction. After this power-on reset, certain important internal registers will be set to defined states before the program commences. One of these registers is the Program Counter, which will be reset to zero forcing the microcontroller to begin program execution from the lowest Program Memory address.

In addition to the power-on reset, situations may arise where it is necessary to forcefully apply a reset condition when the device is running. One example of this is where after power has been applied and the device is already running, the $\overline{\text{RES}}$ line is forcefully pulled low. In such a case, known as a normal operation reset, some of the registers remain unchanged allowing the device to proceed with normal operation after the reset line is allowed to return high.

Another type of reset is when the Watchdog Timer overflows and resets. All types of reset operations result in different register conditions being setup. Another reset exists in the form of a Low Voltage Reset, LVR, where a full reset, is implemented in situations where the power supply voltage falls below a certain threshold.

Reset Functions

There are several ways in which a microcontroller reset can occur, through events occurring both internally and externally.

Power-on Reset

The most fundamental and unavoidable reset is the one that occurs after power is first applied to the microcontroller. As well as ensuring that the Program Memory begins execution from the first memory address, a power-on reset also ensures that certain other registers are preset to known conditions. All the I/O port and port control registers will power up in a high condition ensuring that all I/O ports will be first set to inputs.

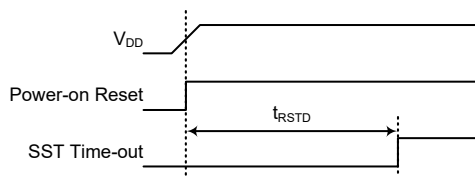

Note: t_{RSTD} is power-on delay specified in System Start Up Time Characteristics.

Power-On Reset Timing Chart

RES Pin Reset

As the reset pin is shared with I/O pins, the reset function must be selected using a control register, RSTC. Although the microcontroller has an internal RC reset function, if the V_{DD} power supply rise time is not fast enough or does not stabilise quickly at power-on, the internal reset function may be incapable of providing proper reset operation. For this reason it is recommended that an external RC network is connected to the \overline{RES} pin, whose additional time delay will ensure that the \overline{RES} pin remains low for an extended period to allow the power supply to stabilise. During this time delay, normal operation of the microcontroller will be inhibited. After the \overline{RES} line reaches a certain voltage value, the reset delay time, t_{RSTD} , is invoked to provide an extra delay time after which the microcontroller will begin normal operation. The abbreviation SST in the figures stands for System Start-up Time. For most applications a resistor connected between V_{DD} and the \overline{RES} line and a capacitor connected between V_{SS} and the \overline{RES} pin will provide a suitable external reset circuit. Any wiring connected to the \overline{RES} pin should be kept as short as possible to minimise any stray noise interference. For applications that operate within an environment where more noise is present the Enhanced Reset Circuit shown is recommended.

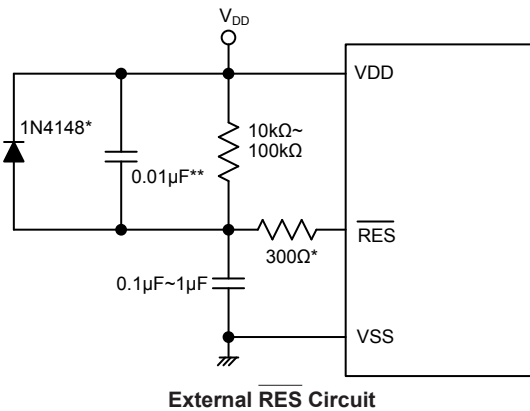

Note: “*” It is recommended that this component is added for added ESD protection.
 “**” It is recommended that this component is added in environments where power line noise is significant.

Pulling the \overline{RES} pin low using external hardware will also execute a device reset. In this case, as in the case of other resets, the Program Counter will reset to zero and program execution initiated from this point.

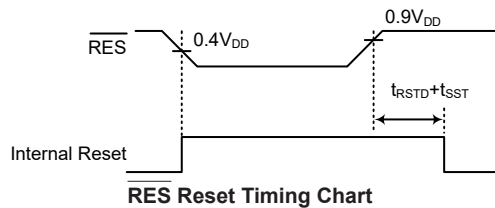

There is an internal reset control register, RSTC, which is used to provide a reset when the device operates abnormally due to the environmental noise interference. If the content of the RSTC register is set to any value other than 01010101B or 10101010B, it will reset the device after a delay time, t_{SRESET} . After power on the register will have a value of 01010101B.

RSTC7~RSTC0 Bits	Reset Function
01010101B	I/O
10101010B	$\overline{\text{RES}}$
Any other value	Reset MCU

Internal Reset Function Control
• RSTC Register

Bit	7	6	5	4	3	2	1	0
Name	RSTC7	RSTC6	RSTC5	RSTC4	RSTC3	RSTC2	RSTC1	RSTC0
R/W	R/W	R/W	R/W	R/W	R/W	R/W	R/W	R/W
POR	0	1	0	1	0	1	0	1

Bit 7~0 **RSTC7~RSTC0**: Reset function control
 01010101: I/O pin
 10101010: $\overline{\text{RES}}$ pin
 Other values: Reset MCU

If these bits are changed due to adverse environmental conditions, the microcontroller will be reset. The reset operation will be activated after a delay time, t_{SRESET} , and the RSTF bit in the RSTFC register will be set to 1. All resets will reset this register to POR value except the WDT time out hardware warm reset. Note that if the register is set to 10101010 to select the $\overline{\text{RES}}$ pin, this configuration has higher priority than other related pin-shared controls.

• RSTFC Register

Bit	7	6	5	4	3	2	1	0
Name	—	—	—	—	RSTF	LVRF	LRF	WRF
R/W	—	—	—	—	R/W	R/W	R/W	R/W
POR	—	—	—	—	0	x	0	0

“x”: Unknown

Bit 7~4 Unimplemented, read as “0”

Bit 3 **RSTF**: Reset control register software reset flag
 0: Not occurred
 1: Occurred

This bit is set to 1 by the RSTC control register software reset and cleared by the application program. Note that this bit can only be cleared to 0 by the application program.

Bit 2 **LVRF**: LVR function reset flag
 Refer to the “Low Voltage Reset” section

Bit 1 **LRF**: LVR control register software reset flag
 Refer to the “Low Voltage Reset” section

Bit 0 **WRF**: WDT control register software reset flag
 Refer to the “Watchdog Timer Control Register” section

Low Voltage Reset – LVR

The microcontroller contains a low voltage reset circuit in order to monitor the supply voltage of the device and provides an MCU reset should the value fall below a certain predefined level. The LVR function can be enabled or disabled by the LVRC control register. If the LVRC control register is configured to enable the LVR function, the LVR function will be always enabled except in the SLEEP or IDLE mode. If the supply voltage of the device drops to within a range of $0.9V \sim V_{LVR}$ such as might occur when changing the battery, the LVR will automatically reset the device internally and the LVRF bit in the RSTFC register will also be set high. For a valid LVR signal, a low supply voltage, i.e., a voltage in the range between $0.9V \sim V_{LVR}$ must exist for a time greater than that specified by t_{LVR} in the LVD/LVR Electrical Characteristics. If the low supply voltage state does not exceed this value, the LVR will ignore the low supply voltage and will not perform a reset function. The actual V_{LVR} value can be selected by the LVS7~LVS0 bits in the LVRC register. If the LVS7~LVS0 bits are changed to some certain values by the environmental noise or software setting, the LVR will reset the device after a delay time, t_{SRESET} . When this happens, the LRF bit in the RSTFC register will be set high. After power on the register will have the value of 01100110B. Note that the LVR function will be automatically disabled when the device enters the IDLE/SLEEP mode.

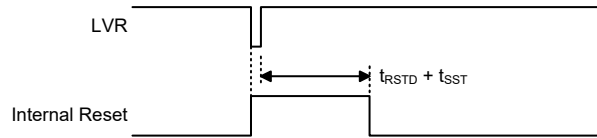

Low Voltage Reset Timing Chart

• **LVRC Register**

Bit	7	6	5	4	3	2	1	0
Name	LVS7	LVS6	LVS5	LVS4	LVS3	LVS2	LVS1	LVS0
R/W	R/W	R/W	R/W	R/W	R/W	R/W	R/W	R/W
POR	0	1	1	0	0	1	1	0

Bit 7~0 **LVS7~LVS0: LVR voltage select**

- 01100110: 1.7V
- 01010101: 1.9V
- 00110011: 2.55V
- 10011001: 3.15V
- 10101010: 3.8V
- 11110000: LVR disable

Other values: MCU reset (register is reset to POR value)

When an actual low voltage condition occurs, as specified by one of the five defined LVR voltage values above, an MCU reset will be generated. The reset operation will be activated after the low voltage condition keeps more than a t_{LVR} time. In this situation the register contents will remain the same after such a reset occurs.

Any register value, other than 11110000B and the five defined LVR values above, will also result in the generation of an MCU reset. The reset operation will be activated after a delay time, t_{SRESET} . However in this situation the register contents will be reset to the POR value.

• **RSTFC Register**

Bit	7	6	5	4	3	2	1	0
Name	—	—	—	—	RSTF	LVRF	LRF	WRF
R/W	—	—	—	—	R/W	R/W	R/W	R/W
POR	—	—	—	—	0	x	0	0

“x”: Unknown

- Bit 7~4 Unimplemented, read as “0”
- Bit 3 **RSTF**: Reset control register software reset flag
Refer to the “Internal Reset Control” section
- Bit 2 **LVRF**: LVR function reset flag
0: Not occur
1: Occurred
This bit is set high when a specific Low Voltage Reset situation occurs. This bit can only be cleared to zero by the application program.
- Bit 1 **LRF**: LVR control register software reset flag
0: Not occur
1: Occurred
This bit is set high if the LVRC register contains any non-defined LVR voltage register values. This in effect acts like a software-reset function. This bit can only be cleared to zero by the application program.
- Bit 0 **WRF**: WDT control register software reset flag
Refer to the “Watchdog Timer Control Register” section

In Application Programming Reset

When a specific value of “55H” is written into the FC1 register, a reset signal will be generated to reset the whole device. Refer to the IAP section for more associated details.

Watchdog Time-out Reset during Normal Operation

When a Watchdog time-out Reset occurs during normal operation, the Watchdog time-out flag TO will be set to “1”.

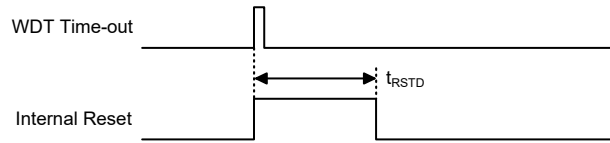

WDT Time-out Reset during Normal Operation Timing Chart

Watchdog Time-out Reset during SLEEP or IDLE Mode

The Watchdog time-out Reset during SLEEP or IDLE Mode is a little different from other kinds of reset. Most of the conditions remain unchanged except that the Program Counter and the Stack Pointer will be cleared to zero and the TO flag will be set high. Refer to the System Start Up Time Characteristics for t_{SST} details.

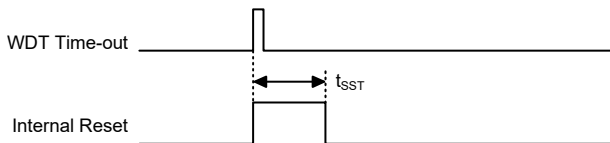

WDT Time-out Reset during SLEEP or IDLE Mode Timing Chart

Reset Initial Conditions

The different types of reset described affect the reset flags in different ways. These flags, known as PDF and TO are located in the status register and are controlled by various microcontroller operations, such as the SLEEP or IDLE Mode function or Watchdog Timer. The reset flags are shown in the table:

TO	PDF	Reset Conditions
0	0	Power-on reset
u	u	RES or LVR reset during FAST or SLOW Mode operation
1	u	WDT time-out reset during FAST or SLOW Mode operation
1	1	WDT time-out reset during IDLE or SLEEP Mode operation

“u”: Unchanged

The following table indicates the way in which the various components of the microcontroller are affected after a power-on reset occurs.

Item	Condition after Reset
Program Counter	Reset to zero
Interrupts	All interrupts will be disabled
WDT, Time Bases	Clear after reset, WDT begins counting
Timer Modules	All Timer Modules will be turned off
Input/Output Ports	I/O ports will be setup as inputs
Stack Pointer	Stack Pointer will point to the top of the stack

The different kinds of resets all affect the internal registers of the microcontroller in different ways. To ensure reliable continuation of normal program execution after a reset occurs, it is important to know what condition the microcontroller is in after a particular reset occurs. The following table describes how each type of reset affects each of the microcontroller internal registers.

Register	Reset (Power On)	RES Reset (Normal Operation)	RES Reset (IDLE/SLEEP)	WDT Time-out (Normal Operation)	WDT Time-out (IDLE/SLEEP)
IAR0	0000 0000	0000 0000	0000 0000	0000 0000	uuuu uuuu
MP0	0000 0000	0000 0000	0000 0000	0000 0000	uuuu uuuu
IAR1	0000 0000	0000 0000	0000 0000	0000 0000	uuuu uuuu
MP1L	0000 0000	0000 0000	0000 0000	0000 0000	uuuu uuuu
MP1H	0000 0000	0000 0000	0000 0000	0000 0000	uuuu uuuu
ACC	x xxx x xxx	uuuu uuuu	uuuu uuuu	uuuu uuuu	uuuu uuuu
PCL	0000 0000	0000 0000	0000 0000	0000 0000	0000 0000
TBLP	x xxx x xxx	uuuu uuuu	uuuu uuuu	uuuu uuuu	uuuu uuuu
TBLH	x xxx x xxx	uuuu uuuu	uuuu uuuu	uuuu uuuu	uuuu uuuu
TBHP	--xx xxxx	--uu uuuu	--uu uuuu	--uu uuuu	--uu uuuu
STATUS	xx00 xxxx	uuuu uuuu	uu01 uuuu	uu1u uuuu	uu11 uuuu
PBP	---- ---0	---- ---0	---- ---0	---- ---0	---- ---u
IAR2	0000 0000	0000 0000	0000 0000	0000 0000	uuuu uuuu
MP2L	0000 0000	0000 0000	0000 0000	0000 0000	uuuu uuuu
MP2H	0000 0000	0000 0000	0000 0000	0000 0000	uuuu uuuu
RSTFC	---- 0x00	---- uuuu	---- uuuu	---- uuuu	---- uuuu
INTC0	-000 0000	-000 0000	-000 0000	-000 0000	-uuu uuuu
INTC1	0000 0000	0000 0000	0000 0000	0000 0000	uuuu uuuu
INTC2	0000 0000	0000 0000	0000 0000	0000 0000	uuuu uuuu
INTC3	0000 0000	0000 0000	0000 0000	0000 0000	uuuu uuuu
PA	1111 1111	1111 1111	1111 1111	1111 1111	uuuu uuuu
PAC	1111 1111	1111 1111	1111 1111	1111 1111	uuuu uuuu

Register	Reset (Power On)	RES Reset (Normal Operation)	RES Reset (IDLE/SLEEP)	WDT Time-out (Normal Operation)	WDT Time-out (IDLE/SLEEP)
PAPU	0000 0000	0000 0000	0000 0000	0000 0000	uuuu uuuu
PAWU	0000 0000	0000 0000	0000 0000	0000 0000	uuuu uuuu
PB	1111 1111	1111 1111	1111 1111	1111 1111	uuuu uuuu
PBC	1111 1111	1111 1111	1111 1111	1111 1111	uuuu uuuu
PBPU	0000 0000	0000 0000	0000 0000	0000 0000	uuuu uuuu
PC	1111 1111	1111 1111	1111 1111	1111 1111	uuuu uuuu
PCC	1111 1111	1111 1111	1111 1111	1111 1111	uuuu uuuu
PCPU	0000 0000	0000 0000	0000 0000	0000 0000	uuuu uuuu
PD	-111 1111	-111 1111	-111 1111	-111 1111	-uuu uuuu
PDC	-111 1111	-111 1111	-111 1111	-111 1111	-uuu uuuu
PDPU	-000 0000	-000 0000	-000 0000	-000 0000	-uuu uuuu
PE	---1 1111	---1 1111	---1 1111	---1 1111	---u uuuu
PEC	---1 1111	---1 1111	---1 1111	---1 1111	---u uuuu
PEPU	---0 0000	---0 0000	---0 0000	---0 0000	---u uuuu
PF	1111 1111	1111 1111	1111 1111	1111 1111	uuuu uuuu
PFC	1111 1111	1111 1111	1111 1111	1111 1111	uuuu uuuu
PFPU	0000 0000	0000 0000	0000 0000	0000 0000	uuuu uuuu
CRCCR	---- ---0	---- ---0	---- ---0	---- ---0	---- ---u
CRCIN	0000 0000	0000 0000	0000 0000	0000 0000	uuuu uuuu
CRCDL	0000 0000	0000 0000	0000 0000	0000 0000	uuuu uuuu
CRCDH	0000 0000	0000 0000	0000 0000	0000 0000	uuuu uuuu
IECC	0000 0000	0000 0000	0000 0000	0000 0000	uuuu uuuu
PMPS	---- --00	---- --00	---- --00	---- --00	---- --uu
RSTC	0101 0101	0101 0101	0101 0101	0101 0101	uuuu uuuu
VBGRC	---- ---0	---- ---0	---- ---0	---- ---0	---- ---u
INTEG	0000 0000	0000 0000	0000 0000	0000 0000	uuuu uuuu
SCC	000- 0000	000- 0000	000- 0000	000- 0000	uuu- uuuu
HIRCC	---- 0001	---- 0001	---- 0001	---- 0001	---- uuuu
HXTC	---- -000	---- -000	---- -000	---- -000	---- -uuu
LXTC	---- -100	---- -100	---- -100	---- -100	---- -1uu
WDTC	0101 0011	0101 0011	0101 0011	0101 0011	uuuu uuuu
LVRC	0110 0110	0110 0110	0110 0110	0110 0110	uuuu uuuu
LVDC	--00 -000	--00 -000	--00 -000	--00 -000	--uu -uuu
EEAL	0000 0000	0000 0000	0000 0000	0000 0000	uuuu uuuu
EEAH	---- --00	---- --00	---- --00	---- --00	---- --uu
EED	0000 0000	0000 0000	0000 0000	0000 0000	uuuu uuuu
CMP1C	-000 00--	-000 00--	-000 00--	-000 00--	-uuu uu--
MF10	0000 0000	0000 0000	0000 0000	0000 0000	uuuu uuuu
MF11	0000 0000	0000 0000	0000 0000	0000 0000	uuuu uuuu
MF12	--00 --00	--00 --00	--00 --00	--00 --00	--uu --uu
MF13	0000 0000	0000 0000	0000 0000	0000 0000	uuuu uuuu
MF14	0000 0000	0000 0000	0000 0000	0000 0000	uuuu uuuu
MF15	--00 --00	--00 --00	--00 --00	--00 --00	--uu --uu
SCOMC	-000 ----	-000 ----	-000 ----	-000 ----	-uuu ----
SLEDC0	0000 0000	0000 0000	0000 0000	0000 0000	uuuu uuuu
SLEDC1	0000 0000	0000 0000	0000 0000	0000 0000	uuuu uuuu
SLEDC2	0000 0000	0000 0000	0000 0000	0000 0000	uuuu uuuu

Register	Reset (Power On)	RES Reset (Normal Operation)	RES Reset (IDLE/SLEEP)	WDT Time-out (Normal Operation)	WDT Time-out (IDLE/SLEEP)
MDUWR0	x xxx x xxx	0 0 0 0 0 0 0 0	0 0 0 0 0 0 0 0	0 0 0 0 0 0 0 0	u u u u u u u u
MDUWR1	x xxx x xxx	0 0 0 0 0 0 0 0	0 0 0 0 0 0 0 0	0 0 0 0 0 0 0 0	u u u u u u u u
MDUWR2	x xxx x xxx	0 0 0 0 0 0 0 0	0 0 0 0 0 0 0 0	0 0 0 0 0 0 0 0	u u u u u u u u
MDUWR3	x xxx x xxx	0 0 0 0 0 0 0 0	0 0 0 0 0 0 0 0	0 0 0 0 0 0 0 0	u u u u u u u u
MDUWR4	x xxx x xxx	0 0 0 0 0 0 0 0	0 0 0 0 0 0 0 0	0 0 0 0 0 0 0 0	u u u u u u u u
MDUWR5	x xxx x xxx	0 0 0 0 0 0 0 0	0 0 0 0 0 0 0 0	0 0 0 0 0 0 0 0	u u u u u u u u
MDUWCTRL	0 0 - - - - -	0 0 - - - - -	0 0 - - - - -	0 0 - - - - -	u u - - - - -
CMP1VOS	- 0 0 1 0 0 0 0 0	- 0 0 1 0 0 0 0 0	- 0 0 1 0 0 0 0 0	- 0 0 1 0 0 0 0 0	- u u u u u u u u
PSC0R	- - - - - 0 0	- - - - - 0 0	- - - - - 0 0	- - - - - 0 0	- - - - - u u
TB0C	0 - - - - 0 0 0	0 - - - - 0 0 0	0 - - - - 0 0 0	0 - - - - 0 0 0	u - - - - u u u
TB1C	0 - - - - 0 0 0	0 - - - - 0 0 0	0 - - - - 0 0 0	0 - - - - 0 0 0	u - - - - u u u
PSC1R	- - - - - 0 0	- - - - - 0 0	- - - - - 0 0	- - - - - 0 0	- - - - - u u
SADOL	x xxx - - - -	x xxx - - - -	x xxx - - - -	x xxx - - - -	u u u u - - - - (ADRFS=0)
					u u u u u u u u (ADRFS=1)
SADOH	x xxx x xxx	x xxx x xxx	x xxx x xxx	x xxx x xxx	u u u u u u u u (ADRFS=0)
					- - - - u u u u (ADRFS=1)
SADC0	0 0 0 0 0 0 0 0	0 0 0 0 0 0 0 0	0 0 0 0 0 0 0 0	0 0 0 0 0 0 0 0	u u u u u u u u
SADC1	0 0 0 0 - 0 0 0	0 0 0 0 - 0 0 0	0 0 0 0 - 0 0 0	0 0 0 0 - 0 0 0	u u u u - u u u
SADC2	0 - - 0 0 0 0 0	0 - - 0 0 0 0 0	0 - - 0 0 0 0 0	0 - - 0 0 0 0 0	u - - u u u u u
SIMC0	1 1 1 - 0 0 0 0	1 1 1 - 0 0 0 0	1 1 1 - 0 0 0 0	1 1 1 - 0 0 0 0	u u u - u u u u
SIMC1	1 0 0 0 0 0 0 1	1 0 0 0 0 0 0 1	1 0 0 0 0 0 0 1	1 0 0 0 0 0 0 1	u u u u u u u u
SIMD	x xxx x xxx	x xxx x xxx	x xxx x xxx	x xxx x xxx	u u u u u u u u
SIMA/SIMC2	0 0 0 0 0 0 0 0	0 0 0 0 0 0 0 0	0 0 0 0 0 0 0 0	0 0 0 0 0 0 0 0	u u u u u u u u
SIMTOC	0 0 0 0 0 0 0 0	0 0 0 0 0 0 0 0	0 0 0 0 0 0 0 0	0 0 0 0 0 0 0 0	u u u u u u u u
FARL	0 0 0 0 0 0 0 0	0 0 0 0 0 0 0 0	0 0 0 0 0 0 0 0	0 0 0 0 0 0 0 0	u u u u u u u u
FARH	- - 0 0 0 0 0 0	- - 0 0 0 0 0 0	- - 0 0 0 0 0 0	- - 0 0 0 0 0 0	- - u u u u u u
FD0L	0 0 0 0 0 0 0 0	0 0 0 0 0 0 0 0	0 0 0 0 0 0 0 0	0 0 0 0 0 0 0 0	u u u u u u u u
FD0H	0 0 0 0 0 0 0 0	0 0 0 0 0 0 0 0	0 0 0 0 0 0 0 0	0 0 0 0 0 0 0 0	u u u u u u u u
FD1L	0 0 0 0 0 0 0 0	0 0 0 0 0 0 0 0	0 0 0 0 0 0 0 0	0 0 0 0 0 0 0 0	u u u u u u u u
FD1H	0 0 0 0 0 0 0 0	0 0 0 0 0 0 0 0	0 0 0 0 0 0 0 0	0 0 0 0 0 0 0 0	u u u u u u u u
FD2L	0 0 0 0 0 0 0 0	0 0 0 0 0 0 0 0	0 0 0 0 0 0 0 0	0 0 0 0 0 0 0 0	u u u u u u u u
FD2H	0 0 0 0 0 0 0 0	0 0 0 0 0 0 0 0	0 0 0 0 0 0 0 0	0 0 0 0 0 0 0 0	u u u u u u u u
FD3L	0 0 0 0 0 0 0 0	0 0 0 0 0 0 0 0	0 0 0 0 0 0 0 0	0 0 0 0 0 0 0 0	u u u u u u u u
FD3H	0 0 0 0 0 0 0 0	0 0 0 0 0 0 0 0	0 0 0 0 0 0 0 0	0 0 0 0 0 0 0 0	u u u u u u u u
LVPUC	- - - - - 0	- - - - - 0	- - - - - 0	- - - - - 0	- - - - - u
PTM0C0	0 0 0 0 0 - - -	0 0 0 0 0 - - -	0 0 0 0 0 - - -	0 0 0 0 0 - - -	u u u u u - - -
PTM0C1	0 0 0 0 0 0 0 0	0 0 0 0 0 0 0 0	0 0 0 0 0 0 0 0	0 0 0 0 0 0 0 0	u u u u u u u u
PTM0DL	0 0 0 0 0 0 0 0	0 0 0 0 0 0 0 0	0 0 0 0 0 0 0 0	0 0 0 0 0 0 0 0	u u u u u u u u
PTM0DH	- - - - - 0 0	- - - - - 0 0	- - - - - 0 0	- - - - - 0 0	- - - - - u u
PTM0AL	0 0 0 0 0 0 0 0	0 0 0 0 0 0 0 0	0 0 0 0 0 0 0 0	0 0 0 0 0 0 0 0	u u u u u u u u
PTM0AH	- - - - - 0 0	- - - - - 0 0	- - - - - 0 0	- - - - - 0 0	- - - - - u u
PTM0RPL	0 0 0 0 0 0 0 0	0 0 0 0 0 0 0 0	0 0 0 0 0 0 0 0	0 0 0 0 0 0 0 0	u u u u u u u u
PTM0RPH	- - - - - 0 0	- - - - - 0 0	- - - - - 0 0	- - - - - 0 0	- - - - - u u
STM0C0	0 0 0 0 0 - - -	0 0 0 0 0 - - -	0 0 0 0 0 - - -	0 0 0 0 0 - - -	u u u u u - - -

Register	Reset (Power On)	RES Reset (Normal Operation)	RES Reset (IDLE/SLEEP)	WDT Time-out (Normal Operation)	WDT Time-out (IDLE/SLEEP)
STM0C1	0000 0000	0000 0000	0000 0000	0000 0000	uuuu uuuu
STM0DL	0000 0000	0000 0000	0000 0000	0000 0000	uuuu uuuu
STM0DH	0000 0000	0000 0000	0000 0000	0000 0000	uuuu uuuu
STM0AL	0000 0000	0000 0000	0000 0000	0000 0000	uuuu uuuu
STM0AH	0000 0000	0000 0000	0000 0000	0000 0000	uuuu uuuu
STM0RP	0000 0000	0000 0000	0000 0000	0000 0000	uuuu uuuu
FC0	0000 0000	0000 0000	0000 0000	0000 0000	uuuu uuuu
FC1	0000 0000	0000 0000	0000 0000	0000 0000	uuuu uuuu
FC2	---- --00	---- --00	---- --00	---- --00	---- --uu
U0SR	0000 1011	0000 1011	0000 1011	0000 1011	uuuu uuuu
U0CR1	0000 00x0	0000 00x0	0000 00x0	0000 00x0	uuuu uuuu
U0CR2	0000 0000	0000 0000	0000 0000	0000 0000	uuuu uuuu
BRDH0	0000 0000	0000 0000	0000 0000	0000 0000	uuuu uuuu
BRDL0	0000 0000	0000 0000	0000 0000	0000 0000	uuuu uuuu
UFCR0	--00 0000	--00 0000	--00 0000	--00 0000	--uu uuuu
TXR_RXR0	xxxx xxxx	xxxx xxxx	xxxx xxxx	xxxx xxxx	uuuu uuuu
RxCNT0	---- -000	---- -000	---- -000	---- -000	---- -uuu
PTM1C0	0000 0---	0000 0---	0000 0---	0000 0---	uuuu u---
PTM1C1	0000 0000	0000 0000	0000 0000	0000 0000	uuuu uuuu
PTM1DL	0000 0000	0000 0000	0000 0000	0000 0000	uuuu uuuu
PTM1DH	---- --00	---- --00	---- --00	---- --00	---- --uu
PTM1AL	0000 0000	0000 0000	0000 0000	0000 0000	uuuu uuuu
PTM1AH	---- --00	---- --00	---- --00	---- --00	---- --uu
PTM1RPL	0000 0000	0000 0000	0000 0000	0000 0000	uuuu uuuu
PTM1RPH	---- --00	---- --00	---- --00	---- --00	---- --uu
PTM2C0	0000 0---	0000 0---	0000 0---	0000 0---	uuuu u---
PTM2C1	0000 0000	0000 0000	0000 0000	0000 0000	uuuu uuuu
PTM2DL	0000 0000	0000 0000	0000 0000	0000 0000	uuuu uuuu
PTM2DH	0000 0000	0000 0000	0000 0000	0000 0000	uuuu uuuu
PTM2AL	0000 0000	0000 0000	0000 0000	0000 0000	uuuu uuuu
PTM2AH	0000 0000	0000 0000	0000 0000	0000 0000	uuuu uuuu
PTM2RPL	0000 0000	0000 0000	0000 0000	0000 0000	uuuu uuuu
PTM2RPH	0000 0000	0000 0000	0000 0000	0000 0000	uuuu uuuu
PTM3C0	0000 0---	0000 0---	0000 0---	0000 0---	uuuu u---
PTM3C1	0000 0000	0000 0000	0000 0000	0000 0000	uuuu uuuu
PTM3DL	0000 0000	0000 0000	0000 0000	0000 0000	uuuu uuuu
PTM3DH	0000 0000	0000 0000	0000 0000	0000 0000	uuuu uuuu
PTM3AL	0000 0000	0000 0000	0000 0000	0000 0000	uuuu uuuu
PTM3AH	0000 0000	0000 0000	0000 0000	0000 0000	uuuu uuuu
PTM3RPL	0000 0000	0000 0000	0000 0000	0000 0000	uuuu uuuu
PTM3RPH	0000 0000	0000 0000	0000 0000	0000 0000	uuuu uuuu
STM1C0	0000 0---	0000 0---	0000 0---	0000 0---	uuuu u---
STM1C1	0000 0000	0000 0000	0000 0000	0000 0000	uuuu uuuu
STM1DL	0000 0000	0000 0000	0000 0000	0000 0000	uuuu uuuu
STM1DH	0000 0000	0000 0000	0000 0000	0000 0000	uuuu uuuu
STM1AL	0000 0000	0000 0000	0000 0000	0000 0000	uuuu uuuu
STM1AH	0000 0000	0000 0000	0000 0000	0000 0000	uuuu uuuu

Register	Reset (Power On)	RES Reset (Normal Operation)	RES Reset (IDLE/SLEEP)	WDT Time-out (Normal Operation)	WDT Time-out (IDLE/SLEEP)
STM1RP	0000 0000	0000 0000	0000 0000	0000 0000	uuuu uuuu
EEC	0000 0000	0000 0000	0000 0000	0000 0000	uuuu uuuu
U1SR	0000 1011	0000 1011	0000 1011	0000 1011	uuuu uuuu
U1CR1	0000 00x0	0000 00x0	0000 00x0	0000 00x0	uuuu uuuu
U1CR2	0000 0000	0000 0000	0000 0000	0000 0000	uuuu uuuu
BRDH1	0000 0000	0000 0000	0000 0000	0000 0000	uuuu uuuu
BRDL1	0000 0000	0000 0000	0000 0000	0000 0000	uuuu uuuu
UFCR1	--00 0000	--00 0000	--00 0000	--00 0000	--uu uuuu
TXR_RXR1	xxxx xxxx	xxxx xxxx	xxxx xxxx	xxxx xxxx	uuuu uuuu
RxCNT1	---- -000	---- -000	---- -000	---- -000	---- -uuu
IFS0	-000 0000	-000 0000	-000 0000	-000 0000	-uuu uuuu
IFS1	-000 0000	-000 0000	-000 0000	-000 0000	-uuu uuuu
IFS2	-000 0000	-000 0000	-000 0000	-000 0000	-uuu uuuu
IFS3	---- --00	---- --00	---- --00	---- --00	---- --uu
PAS0	00-- 00--	00-- 00--	00-- 00--	00-- 00--	uu-- uu--
PAS1	0000 0000	0000 0000	0000 0000	0000 0000	uuuu uuuu
PBS0	0000 0000	0000 0000	0000 0000	0000 0000	uuuu uuuu
PBS1	0000 --00	0000 --00	0000 --00	0000 --00	uuuu --uu
PCS0	0000 0000	0000 0000	0000 0000	0000 0000	uuuu uuuu
PCS1	0000 0000	0000 0000	0000 0000	0000 0000	uuuu uuuu
PDS0	0000 0000	0000 0000	0000 0000	0000 0000	uuuu uuuu
PDS1	--00 0000	--00 0000	--00 0000	--00 0000	--uu uuuu
PES0	0000 0000	0000 0000	0000 0000	0000 0000	uuuu uuuu
PES1	---- --00	---- --00	---- --00	---- --00	---- --uu
PFS0	0000 0000	0000 0000	0000 0000	0000 0000	uuuu uuuu
PFS1	0000 0000	0000 0000	0000 0000	0000 0000	uuuu uuuu

Note: “u” stands for unchanged
 “x” stands for unknown
 “-” stands for unimplemented

Input/Output Ports

Holtek microcontrollers offer considerable flexibility on their I/O ports. With the input or output designation of every pin fully under user program control, pull-high selections for all ports and wake-up selections on certain pins, the user is provided with an I/O structure to meet the needs of a wide range of application possibilities.

The device provides bidirectional input/output lines labeled with port names PA~PF. These I/O ports are mapped to the RAM Data Memory with specific addresses as shown in the Special Purpose Data Memory table. All of these I/O ports can be used for input and output operations. For input operation, these ports are non-latching, which means the inputs must be ready at the T2 rising edge of instruction “MOV A, [m]”, where m denotes the port address. For output operation, all the data is latched and remains unchanged until the output latch is rewritten.

Register Name	Bit							
	7	6	5	4	3	2	1	0
PA	PA7	PA6	PA5	PA4	PA3	PA2	PA1	PA0
PAC	PAC7	PAC6	PAC5	PAC4	PAC3	PAC2	PAC1	PAC0
PAPU	PAPU7	PAPU6	PAPU5	PAPU4	PAPU3	PAPU2	PAPU1	PAPU0
PAWU	PAWU7	PAWU6	PAWU5	PAWU4	PAWU3	PAWU2	PAWU1	PAWU0
PB	PB7	PB6	PB5	PB4	PB3	PB2	PB1	PB0
PBC	PBC7	PBC6	PBC5	PBC4	PBC3	PBC2	PBC1	PBC0
PBPU	PBPU7	PBPU6	PBPU5	PBPU4	PBPU3	PBPU2	PBPU1	PBPU0
PC	PC7	PC6	PC5	PC4	PC3	PC2	PC1	PC0
PCC	PCC7	PCC6	PCC5	PCC4	PCC3	PCC2	PCC1	PCC0
PCPU	PCPU7	PCPU6	PCPU5	PCPU4	PCPU3	PCPU2	PCPU1	PCPU0
PD	—	PD6	PD5	PD4	PD3	PD2	PD1	PD0
PDC	—	PDC6	PDC5	PDC4	PDC3	PDC2	PDC1	PDC0
PDPU	—	PDPU6	PDPU5	PDPU4	PDPU3	PDPU2	PDPU1	PDPU0
PE	—	—	—	PE4	PE3	PE2	PE1	PE0
PEC	—	—	—	PEC4	PEC3	PEC2	PEC1	PEC0
PEPU	—	—	—	PEPU4	PEPU3	PEPU2	PEPU1	PEPU0
PF	PF7	PF6	PF5	PF4	PF3	PF2	PF1	PF0
PFC	PFC7	PFC6	PFC5	PFC4	PFC3	PFC2	PFC1	PFC0
PFPU	PFPU7	PFPU6	PFPU5	PFPU4	PFPU3	PFPU2	PFPU1	PFPU0
LVPUC	—	—	—	—	—	—	—	LVPUC

“—”: Unimplemented

Input/Output Logic Function Register List

Pull-high Resistors

Many product applications require pull-high resistors for their switch inputs usually requiring the use of an external resistor. To eliminate the need for these external resistors, all I/O pins, when configured as a digital input have the capability of being connected to an internal pull-high resistor. These pull-high resistors are selected using the LVPUC and PxPU registers, and are implemented using weak PMOS transistors. The PxPU register is used to determine whether the pull-high function is enabled or not while the LVPUC register is used to select the pull-high resistors value for low voltage power supply applications.

Note that the pull-high resistor can be controlled by the relevant pull-high control register only when the pin-shared functional pin is selected as an digital input or NMOS output. Otherwise, the pull-high resistors cannot be enabled.

• **PxPU Register**

Bit	7	6	5	4	3	2	1	0
Name	PxPU7	PxPU6	PxPU5	PxPU4	PxPU3	PxPU2	PxPU1	PxPU0
R/W	R/W	R/W	R/W	R/W	R/W	R/W	R/W	R/W
POR	0	0	0	0	0	0	0	0

PxPUn: I/O port x pin pull-high function control

0: Disable

1: Enable

The PxPUn bit is used to control the pin pull-high function. Here the “x” can be A, B, C, D, E or F. However, the actual available bits for each I/O port may be different.

• **LVPUC Register**

Bit	7	6	5	4	3	2	1	0
Name	—	—	—	—	—	—	—	LVPU
R/W	—	—	—	—	—	—	—	R/W
POR	—	—	—	—	—	—	—	0

Bit 7~1 Unimplemented, read as “0”

Bit 0 **LVPU:** Pull-high resistor selection for low voltage power supply

0: All pin pull-high resistors are 60kΩ @ 3V

1: All pin pull-high resistors are 15kΩ @ 3V

This bit is used to select the pull-high resistor value for low voltage power supply applications. The LVPU bit is only available when the corresponding pin pull-high function is enabled by setting the relevant pull-high control bit high. This bit will have no effect when the pull-high function is disabled.

Port A Wake-up

The HALT instruction forces the microcontroller into the SLEEP or IDLE Mode which preserves power, a feature that is important for battery and other low-power applications. Various methods exist to wake-up the microcontroller, one of which is to change the logic condition on one of the Port A pins from high to low. This function is especially suitable for applications that can be woken up via external switches. Each pin on Port A can be selected individually to have this wake-up feature using the PAWU register.

Note that the wake-up function can be controlled by the wake-up control registers only when the pin-shared functional pin is selected as general purpose input and the MCU enters the IDLE/SLEEP mode.

• **PAWU Register**

Bit	7	6	5	4	3	2	1	0
Name	PAWU7	PAWU6	PAWU5	PAWU4	PAWU3	PAWU2	PAWU1	PAWU0
R/W	R/W	R/W	R/W	R/W	R/W	R/W	R/W	R/W
POR	0	0	0	0	0	0	0	0

Bit 7~0 **PAWU7~PAWU0:** I/O port A pin wake-up control

0: Disable

1: Enable

I/O Port Control Registers

Each I/O port has its own control register known as PAC~PFC, to control the input/output configuration. With this control register, each CMOS output or input can be reconfigured dynamically under software control. Each pin of the I/O ports is directly mapped to a bit in its

associated port control register. For the I/O pin to function as an input, the corresponding bit of the control register must be written as a “1”. This will then allow the logic state of the input pin to be directly read by instructions. When the corresponding bit of the control register is written as a “0”, the I/O pin will be setup as a CMOS output. If the pin is currently setup as an output, instructions can still be used to read the output register. However, it should be noted that the program will in fact only read the status of the output data latch and not the actual logic status of the output pin when the IECM is set to “0”.

• PxC Register

Bit	7	6	5	4	3	2	1	0
Name	PxC7	PxC6	PxC5	PxC4	PxC3	PxC2	PxC1	PxC0
R/W	R/W	R/W	R/W	R/W	R/W	R/W	R/W	R/W
POR	1	1	1	1	1	1	1	1

PxCn: I/O port x pin type selection

0: Output

1: Input

The PxCn bit is used to control the pin type selection. Here the “x” can be A, B, C, D, E or F. However, the actual available bits for each I/O port may be different.

Note that the PB0~PB1, PC3~PC7, PD0, PD6, PE0 and PF6~PF7 lines are not connected to the external pins, it is recommended that the corresponding PxCn bit should be cleared to zero to set these I/O lines as outputs after power on. This can avoid unwanted power consumption resulting from floating input conditions.

I/O Port Power Source Control

This device supports different I/O port power source selections for PE3~PE1 pins. The port power can come from the power pin VDD or VDDIO, which is determined using the PMPS1~PMPS0 bit field in the PMPS register. The VDDIO power pin function should first be selected using the corresponding pin-shared function selection bits if the port power is supposed to come from the VDDIO pin. An important point to know is that the input power voltage on the VDDIO pin should be equal to or less than the device supply power voltage V_{DD} when the VDDIO pin is selected as the port power supply pin. With the exception of $\overline{RES}/OCDS$, the multi-power function is only available when the pin function is selected as digital input or output function.

• PMPS Register

Bit	7	6	5	4	3	2	1	0
Name	—	—	—	—	—	—	PMPS1	PMPS0
R/W	—	—	—	—	—	—	R/W	R/W
POR	—	—	—	—	—	—	0	0

Bit 7~2 Unimplemented, read as “0”

Bit 1~0 **PMPS1~PMPS0:** PE3~PE1 pin power supply selection

0x: V_{DD}

1x: V_{DDIO}

If the PE4 pin is switched to the VDDIO function, and the PMPS1 and PMPS0 bits are set to “1x”, the VDDIO pin input voltage can be used for PE3~PE1 pin power.

I/O Port Source Current Control

The device supports different source current driving capability for each I/O port. With the corresponding selection registers, SLEDC0, SLEDC1 and SLEDC2, each I/O port can support four levels of the source current driving capability. Users should refer to the Input/Output Characteristics section to select the desired source current for different applications.

• **SLEDC0 Register**

Bit	7	6	5	4	3	2	1	0
Name	SLEDC07	SLEDC06	SLEDC05	SLEDC04	SLEDC03	SLEDC02	SLEDC01	SLEDC00
R/W	R/W	R/W	R/W	R/W	R/W	R/W	R/W	R/W
POR	0	0	0	0	0	0	0	0

- Bit 7~6 **SLEDC07~SLEDC06:** PB7~PB4 source current selection
00: Source current = Level 0 (min.)
01: Source current = Level 1
10: Source current = Level 2
11: Source current = Level 3 (max.)
- Bit 5~4 **SLEDC05~SLEDC04:** PB3~PB2 source current selection
00: Source current = Level 0 (min.)
01: Source current = Level 1
10: Source current = Level 2
11: Source current = Level 3 (max.)
- Bit 3~2 **SLEDC03~SLEDC02:** PA7~PA4 source current selection
00: Source current = Level 0 (min.)
01: Source current = Level 1
10: Source current = Level 2
11: Source current = Level 3 (max.)
- Bit 1~0 **SLEDC01~SLEDC00:** PA3~PA0 source current selection
00: Source current = Level 0 (min.)
01: Source current = Level 1
10: Source current = Level 2
11: Source current = Level 3 (max.)

• **SLEDC1 Register**

Bit	7	6	5	4	3	2	1	0
Name	SLEDC17	SLEDC16	SLEDC15	SLEDC14	SLEDC13	SLEDC12	SLEDC11	SLEDC10
R/W	R/W	R/W	R/W	R/W	R/W	R/W	R/W	R/W
POR	0	0	0	0	0	0	0	0

- Bit 7~6 **SLEDC17~SLEDC16:** PD5~PD4 source current selection
00: Source current = Level 0 (min.)
01: Source current = Level 1
10: Source current = Level 2
11: Source current = Level 3 (max.)
- Bit 5~4 **SLEDC15~SLEDC14:** PD1~PD0 source current selection
00: Source current = Level 0 (min.)
01: Source current = Level 1
10: Source current = Level 2
11: Source current = Level 3 (max.)
- Bit 3~2 **SLEDC13~SLEDC12:** These bits should be kept unchanged after power on
- Bit 1~0 **SLEDC11~SLEDC10:** PC2~PC0 source current selection
00: Source current = Level 0 (min.)
01: Source current = Level 1
10: Source current = Level 2
11: Source current = Level 3 (max.)

• SLEDC2 Register

Bit	7	6	5	4	3	2	1	0
Name	SLEDC27	SLEDC26	SLEDC25	SLEDC24	SLEDC23	SLEDC22	SLEDC21	SLEDC20
R/W	R/W	R/W	R/W	R/W	R/W	R/W	R/W	R/W
POR	0	0	0	0	0	0	0	0

- Bit 7~6 **SLEDC27~SLEDC26:** PF5~PF4 source current selection
 00: Source current = Level 0 (min.)
 01: Source current = Level 1
 10: Source current = Level 2
 11: Source current = Level 3 (max.)
- Bit 5~4 **SLEDC25~SLEDC24:** PF3~PF0 source current selection
 00: Source current = Level 0 (min.)
 01: Source current = Level 1
 10: Source current = Level 2
 11: Source current = Level 3 (max.)
- Bit 3~2 **SLEDC23~SLEDC22:** PE4 source current selection
 00: Source current = Level 0 (min.)
 01: Source current = Level 1
 10: Source current = Level 2
 11: Source current = Level 3 (max.)
- Bit 1~0 **SLEDC21~SLEDC20:** PE3~PE1 source current selection
 00: Source current = Level 0 (min.)
 01: Source current = Level 1
 10: Source current = Level 2
 11: Source current = Level 3 (max.)

Pin-shared Functions

The flexibility of the microcontroller range is greatly enhanced by the use of pins that have more than one function. Limited numbers of pins can force serious design constraints on designers but by supplying pins with multi-functions, many of these difficulties can be overcome. For these pins, the desired function of the multi-function I/O pins is selected by a series of registers via the application program control.

Pin-shared Function Selection Registers

The limited number of supplied pins in a package can impose restrictions on the amount of functions a certain device can contain. However by allowing the same pins to share several different functions and providing a means of function selection, a wide range of different functions can be incorporated into even relatively small package sizes. The device includes Port “x” output function Selection register “n”, labeled as PxSn and Input Function Selection register, labeled as IFSi, which can select the desired functions of the multi-function pin-shared pins.

The most important point to note is to make sure that the desired pin-shared function is properly selected and also deselected. For most pin-shared functions, to select the desired pin-shared function, the pin-shared function should first be correctly selected using the corresponding pin-shared control register. After that the corresponding peripheral functional setting should be configured and then the peripheral function can be enabled. However, special point must be noted for some digital input pins, such as INTn, xTCKn, xTPnI etc, which share the same pin-shared control configuration with their corresponding general purpose I/O functions when setting the relevant functions, in addition to the necessary pin-shared control and peripheral functional setup aforementioned, they must also be setup as input by setting the corresponding bit in the I/O port control register. To correctly deselect the pin-shared function, the peripheral function should first be disabled and then the corresponding pin-shared function control register can be modified to select other pin-shared functions.

Register Name	Bit							
	7	6	5	4	3	2	1	0
PAS0	PAS07	PAS06	—	—	PAS03	PAS02	—	—
PAS1	PAS17	PAS16	PAS15	PAS14	PAS13	PAS12	PAS11	PAS10
PBS0	PBS07	PBS06	PBS05	PBS04	PBS03	PBS02	PBS01	PBS00
PBS1	PBS17	PBS16	PBS15	PBS14	—	—	PBS11	PBS10
PCS0	PCS07	PCS06	PCS05	PCS04	PCS03	PCS02	PCS01	PCS00
PCS1	PCS17	PCS16	PCS15	PCS14	PCS13	PCS12	PCS11	PCS10
PDS0	PDS07	PDS06	PDS05	PDS04	PDS03	PDS02	PDS01	PDS00
PDS1	—	—	PDS15	PDS14	PDS13	PDS12	PDS11	PDS10
PES0	PES07	PES06	PES05	PES04	PES03	PES02	PES01	PES00
PES1	—	—	—	—	—	—	PES11	PES10
PFS0	PFS07	PFS06	PFS05	PFS04	PFS03	PFS02	PFS01	PFS00
PFS1	PFS17	PFS16	PFS15	PFS14	PFS13	PFS12	PFS11	PFS10
IFS0	—	PTCK3PS	PTCK2PS	PTCK1PS	PTCK0PS	STCK2PS	STCK1PS	STCK0PS
IFS1	—	PTP3IPS	PTP2IPS	PTP1IPS	PTP0IPS	STP2IPS	STP1IPS	STP0IPS
IFS2	—	SCSBPS	SDISDAPS	SCKSCLPS	INT3PS	INT2PS	INT1PS	INT0PS
IFS3	—	—	—	—	—	—	RX1PS	RX0PS

Pin-shared Function Selection Register List

• **PAS0 Register**

Bit	7	6	5	4	3	2	1	0
Name	PAS07	PAS06	—	—	PAS03	PAS02	—	—
R/W	R/W	R/W	—	—	R/W	R/W	—	—
POR	0	0	—	—	0	0	—	—

- Bit 7~6 **PAS07~PAS06:** PA3 pin-shared function selection
00: PA3/INT1
01: PA3/INT1
10: PA3/INT1
11: SDO
- Bit 5~4 Unimplemented, read as “0”
- Bit 3~2 **PAS03~PAS02:** PA1 pin-shared function selection
00: PA1/INT0
01: PA1/INT0
10: PA1/INT0
11: SCS
- Bit 1~0 Unimplemented, read as “0”

• PAS1 Register

Bit	7	6	5	4	3	2	1	0
Name	PAS17	PAS16	PAS15	PAS14	PAS13	PAS12	PAS11	PAS10
R/W	R/W	R/W	R/W	R/W	R/W	R/W	R/W	R/W
POR	0	0	0	0	0	0	0	0

Bit 7~6 **PAS17~PAS16:** PA7 pin-shared function selection

00: PA7/INT1
 01: PA7/INT1
 10: PA7/INT1
 11: TX0

Bit 5~4 **PAS15~PAS14:** PA6 pin-shared function selection

00: PA6/INT0
 01: PA6/INT0
 10: PA6/INT0
 11: RX0

Bit 3~2 **PAS13~PAS12:** PA5 pin-shared function selection

00: PA5/INT3
 01: PA5/INT3
 10: PA5/INT3
 11: SCK/SCL

Bit 1~0 **PAS11~PAS10:** PA4 pin-shared function selection

00: PA4/INT2
 01: PA4/INT2
 10: PA4/INT2
 11: SDI/SDA

• PBS0 Register

Bit	7	6	5	4	3	2	1	0
Name	PBS07	PBS06	PBS05	PBS04	PBS03	PBS02	PBS01	PBS00
R/W	R/W	R/W	R/W	R/W	R/W	R/W	R/W	R/W
POR	0	0	0	0	0	0	0	0

Bit 7~6 **PBS07~PBS06:** PB3 pin-shared function selection

00: PB3/PTP2I
 01: PB3/PTP2I
 10: PTP2
 11: AN14

Bit 5~4 **PBS05~PBS04:** PB2 pin-shared function selection

00: PB2/PTP3I/PTCK2
 01: PB2/PTP3I/PTCK2
 10: PTP3
 11: AN13

Bit 3~0 **PBS03~PBS00:** These bits should be kept unchanged after power on

• **PBS1 Register**

Bit	7	6	5	4	3	2	1	0
Name	PBS17	PBS16	PBS15	PBS14	—	—	PBS11	PBS10
R/W	R/W	R/W	R/W	R/W	—	—	R/W	R/W
POR	0	0	0	0	—	—	0	0

- Bit 7~6 **PBS17~PBS16:** PB7 pin-shared function selection
00: PB7/STCK1
01: PB7/STCK1
10: PB7/STCK1
11: OSC2
- Bit 5~4 **PBS15~PBS14:** PB6 pin-shared function selection
00: PB6/STPII
01: PB6/STPII
10: STP1
11: OSC1
- Bit 3~2 Unimplemented, read as “0”
- Bit 1~0 **PBS11~PBS10:** PB4 pin-shared function selection
00: PB4
01: PB4
10: C1X
11: AN15

• **PCS0 Register**

Bit	7	6	5	4	3	2	1	0
Name	PCS07	PCS06	PCS05	PCS04	PCS03	PCS02	PCS01	PCS00
R/W	R/W	R/W	R/W	R/W	R/W	R/W	R/W	R/W
POR	0	0	0	0	0	0	0	0

- Bit 7~6 **PCS07~PCS06:** These bits should be kept unchanged after power on
- Bit 5~4 **PCS05~PCS04:** PC2 pin-shared function selection
00: PC2/PTP0I
01: PC2/PTP0I
10: PTP0
11: AN2
- Bit 3~2 **PCS03~PCS02:** PC1 pin-shared function selection
00: PC1
01: Reserved, cannot be used
10: VREF
11: AN1
- Bit 1~0 **PCS01~PCS00:** PC0 pin-shared function selection
00: PC0
01: PC0
10: VREFI
11: AN0

• PCS1 Register

Bit	7	6	5	4	3	2	1	0
Name	PCS17	PCS16	PCS15	PCS14	PCS13	PCS12	PCS11	PCS10
R/W	R/W	R/W	R/W	R/W	R/W	R/W	R/W	R/W
POR	0	0	0	0	0	0	0	0

Bit 7~0 **PCS17~PCS10**: These bits should be kept unchanged after power on

• PDS0 Register

Bit	7	6	5	4	3	2	1	0
Name	PDS07	PDS06	PDS05	PDS04	PDS03	PDS02	PDS01	PDS00
R/W	R/W	R/W	R/W	R/W	R/W	R/W	R/W	R/W
POR	0	0	0	0	0	0	0	0

Bit 7~6 **PDS07~PDS06**: PD3 pin-shared function selection
 00: PD3/PTCK2
 01: PD3/PTCK2
 10: PD3/PTCK2
 11: AN11

Bit 5~4 **PDS05~PDS04**: PD2 pin-shared function selection
 00: PD2/PTP2I
 01: PTP2
 10: TX1
 11: AN10

Bit 3~2 **PDS03~PDS02**: PD1 pin-shared function selection
 00: PD1/STCK1
 01: PD1/STCK1
 10: RX1
 11: AN9

Bit 1~0 **PDS01~PDS00**: These bits should be kept unchanged after power on

• PDS1 Register

Bit	7	6	5	4	3	2	1	0
Name	—	—	PDS15	PDS14	PDS13	PDS12	PDS11	PDS10
R/W	—	—	R/W	R/W	R/W	R/W	R/W	R/W
POR	—	—	0	0	0	0	0	0

Bit 7~6 Unimplemented, read as “0”

Bit 5~4 **PDS15~PDS14**: These bits should be kept unchanged after power on

Bit 3~2 **PDS13~PDS12**: PD5 pin-shared function selection
 00: PD5/PTCK3
 01: PD5/PTCK3
 10: TX0
 11: C1+

Bit 1~0 **PDS11~PDS10**: PD4 pin-shared function selection
 00: PD4/PTP3I
 01: RX0
 10: PTP3
 11: C1-

• **PES0 Register**

Bit	7	6	5	4	3	2	1	0
Name	PES07	PES06	PES05	PES04	PES03	PES02	PES01	PES00
R/W	R/W	R/W	R/W	R/W	R/W	R/W	R/W	R/W
POR	0	0	0	0	0	0	0	0

Bit 7~6 **PES07~PES06:** PE3 pin-shared function selection

00: PE3/PTP1I
 01: PE3/PTP1I
 10: PTP1
 11: Reserved, cannot be used

Bit 5~4 **PES05~PES04:** PE2 pin-shared function selection

00: PE2/PTCK1
 01: PE2/PTCK1
 10: PE2/PTCK1
 11: Reserved, cannot be used

Bit 3~2 **PES03~PES02:** PE1 pin-shared function selection

00: PE1/STP0I
 01: PE1/STP0I
 10: STP0
 11: Reserved, cannot be used

Bit 1~0 **PES01~PES00:** These bits should be kept unchanged after power on

• **PES1 Register**

Bit	7	6	5	4	3	2	1	0
Name	—	—	—	—	—	—	PES11	PES10
R/W	—	—	—	—	—	—	R/W	R/W
POR	—	—	—	—	—	—	0	0

Bit 7~2 Unimplemented, read as “0”

Bit 1~0 **PES11~PES10:** PE4 pin-shared function selection

00: PE4
 01: PE4
 10: PE4
 11: VDDIO

• **PFS0 Register**

Bit	7	6	5	4	3	2	1	0
Name	PFS07	PFS06	PFS05	PFS04	PFS03	PFS02	PFS01	PFS00
R/W	R/W	R/W	R/W	R/W	R/W	R/W	R/W	R/W
POR	0	0	0	0	0	0	0	0

Bit 7~6 **PFS07~PFS06:** PF3 pin-shared function selection

00: PF3
 01: PF3
 10: SCK/SCL
 11: SCOM3

Bit 5~4 **PFS05~PFS04:** PF2 pin-shared function selection

00: PF2
 01: PF2
 10: SDI/SDA
 11: SCOM2

- Bit 3~2 **PFS03~PFS02**: PF1 pin-shared function selection
 00: PF1
 01: PF1
 10: SDO
 11: SCOM1
- Bit 1~0 **PFS01~PFS00**: PF0 pin-shared function selection
 00: PF0
 01: PF0
 10: \overline{SCS}
 11: SCOM0

• PFS1 Register

Bit	7	6	5	4	3	2	1	0
Name	PFS17	PFS16	PFS15	PFS14	PFS13	PFS12	PFS11	PFS10
R/W	R/W	R/W	R/W	R/W	R/W	R/W	R/W	R/W
POR	0	0	0	0	0	0	0	0

- Bit 7~4 **PFS17~PFS14**: These bits should be kept unchanged after power on
- Bit 3~2 **PFS13~PFS12**: PF5 pin-shared function selection
 00: PF5/PTP0I
 01: PF1/PTP0I
 10: PTP0
 11: XT1
- Bit 1~0 **PFS11~PFS10**: PF4 pin-shared function selection
 00: PF4/PTCK0
 01: PF4/PTCK0
 10: PF4/PTCK0
 11: XT2

• IFS0 Register

Bit	7	6	5	4	3	2	1	0
Name	—	PTCK3PS	PTCK2PS	PTCK1PS	PTCK0PS	STCK2PS	STCK1PS	STCK0PS
R/W	—	R/W	R/W	R/W	R/W	R/W	R/W	R/W
POR	—	0	0	0	0	0	0	0

- Bit 7 Unimplemented, read as “0”
- Bit 6 **PTCK3PS**: PTCK3 input source pin selection
 0: PD5
 1: Reserved, cannot be used
- Bit 5 **PTCK2PS**: PTCK2 input source pin selection
 0: PD3
 1: PB2
- Bit 4 **PTCK1PS**: PTCK1 input source pin selection
 0: Reserved, cannot be used
 1: PE2
- Bit 3 **PTCK0PS**: PTCK0 input source pin selection
 0: Reserved, cannot be used
 1: PF4
- Bit 2 **STCK2PS**: The bit should be kept unchanged after power on
- Bit 1 **STCK1PS**: STCK1 input source pin selection
 0: PD1
 1: PB7
- Bit 0 **STCK0PS**: The bit should be kept unchanged after power on

• **IFS1 Register**

Bit	7	6	5	4	3	2	1	0
Name	—	PTP3IPS	PTP2IPS	PTP1IPS	PTP0IPS	STP2IPS	STP1IPS	STP0IPS
R/W	—	R/W	R/W	R/W	R/W	R/W	R/W	R/W
POR	—	0	0	0	0	0	0	0

- Bit 7 Unimplemented, read as “0”
- Bit 6 **PTP3IPS**: PTP3I input source pin selection
0: PD4
1: PB2
- Bit 5 **PTP2IPS**: PTP2I input source pin selection
0: PD2
1: PB3
- Bit 4 **PTP1IPS**: PTP1I input source pin selection
0: Reserved, cannot be used
1: PE3
- Bit 3 **PTP0IPS**: PTP0I input source pin selection
0: PC2
1: PF5
- Bit 2 **STP2IPS**: The bit should be kept unchanged after power on.
- Bit 1 **STP1IPS**: STP1I input source pin selection
0: Reserved, cannot be used
1: PB6
- Bit 0 **STP0IPS**: STP0I input source pin selection
0: Reserved, cannot be used
1: PE1

• **IFS2 Register**

Bit	7	6	5	4	3	2	1	0
Name	—	SCSBPS	SDISDAPS	SCKSCLPS	INT3PS	INT2PS	INT1PS	INT0PS
R/W	—	R/W	R/W	R/W	R/W	R/W	R/W	R/W
POR	—	0	0	0	0	0	0	0

- Bit 7 Unimplemented, read as “0”
- Bit 6 **SCSBPS**: SCS input source pin selection
0: PA1
1: PF0
- Bit 5 **SDISDAPS**: SDI/SDA input source pin selection
0: PA4
1: PF2
- Bit 4 **SCKSCLPS**: SCK/SCL input source pin selection
0: PA5
1: PF3
- Bit 3 **INT3PS**: INT3 input source pin selection
0: PA5
1: Reserved, cannot be used
- Bit 2 **INT2PS**: INT2 input source pin selection
0: PA4
1: Reserved, cannot be used
- Bit 1 **INT1PS**: INT1 input source pin selection
0: PA3
1: PA7
- Bit 0 **INT0PS**: INT0 input source pin selection
0: PA1
1: PA6

• IFS3 Register

Bit	7	6	5	4	3	2	1	0
Name	—	—	—	—	—	—	RX1PS	RX0PS
R/W	—	—	—	—	—	—	R/W	R/W
POR	—	—	—	—	—	—	0	0

- Bit 7~2 Unimplemented, read as “0”
- Bit 1 **RX1PS**: RX1 input source pin selection
0: PD1
1: Reserved, cannot be used
- Bit 0 **RX0PS**: RX0 input source pin selection
0: PA6
1: PD4

I/O Pin Structures

The accompanying diagram illustrates the internal structures of the I/O logic function. As the exact logical construction of the I/O pin will differ from this diagram, it is supplied as a guide only to assist with the functional understanding of the logic function I/O pins. The wide range of pin-shared structures does not permit all types to be shown.

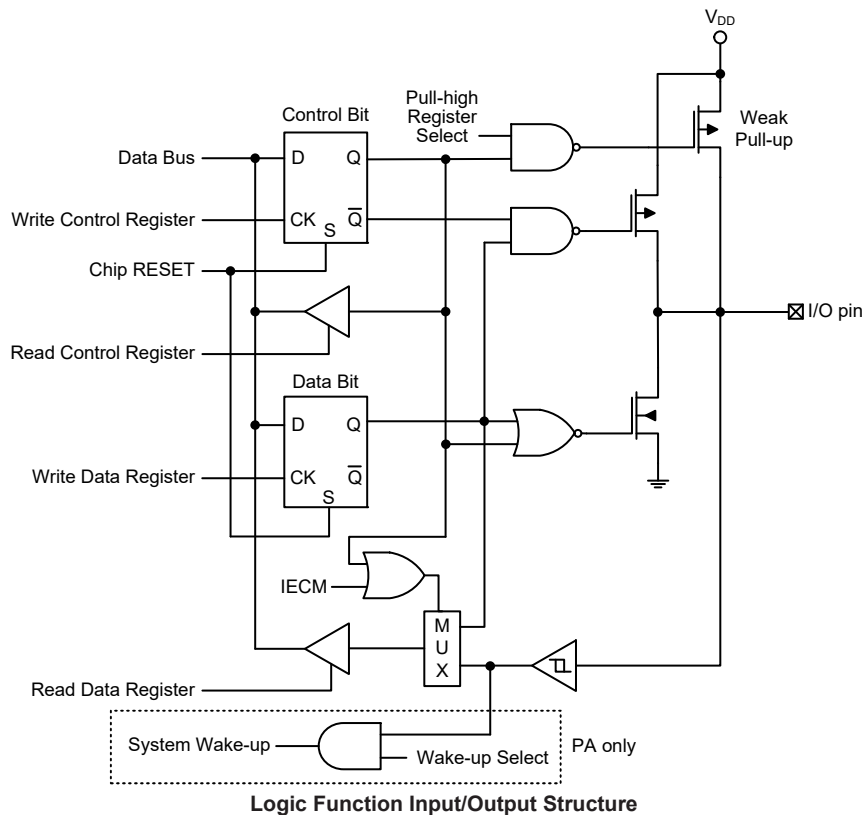

READ PORT Function

The READ PORT function is used to manage the reading of the output data from the data latch or I/O pin, which is specially designed for the IEC60730 self-diagnostic test on the I/O function and A/D paths. There is a register, IECC, which is used to control the READ PORT function. If the READ PORT function is disabled, the pin function will operate as the selected pin-shared function. When a specific data pattern, “11001010”, is written into the IECC register, the internal signal named IECM will be set high to enable the READ PORT function. If the READ PORT function is enabled, the value on the corresponding pins will be passed to the accumulator ACC when the read port instruction “mov acc, Px” is executed where the “x” stands for the corresponding I/O port name.

• IECC Register

Bit	7	6	5	4	3	2	1	0
Name	IECS7	IECS6	IECS5	IECS4	IECS3	IECS2	IECS1	IECS0
R/W	R/W	R/W	R/W	R/W	R/W	R/W	R/W	R/W
POR	0	0	0	0	0	0	0	0

Bit 7~0 **IECS7~IECS0:** READ PORT function enable control bit 7~bit 0
 11001010: IECM=1 – READ PORT function is enabled
 Others: IECM=0 – READ PORT function is disabled

READ PORT Function	Disabled		Enabled	
Port Control Register Bit – Px.C.n	1	0	1	0
I/O Function	Pin value	Data latch value	Pin value	
Digital Input Function				
Digital Output Function (except SIM and UART)				
SIM: SCK/SCL, SDI/SDA UART: RXn/TXn				
Analog Function				
RES	0			

Note: The value on the above table is the content of the ACC register after “mov a, Px” instruction is executed where “x” means the relevant port name.

The additional function of the READ PORT mode is to check the A/D path. When the READ PORT function is disabled, the A/D path from the external pin to the internal analog input will be switched off if the A/D input pin function is not selected by the corresponding selection bits. For the MCU with A/D converter channels, such as A/D AN0~AN2, AN9~AN11, AN13~AN15, the desired A/D channel can be switched on by properly configuring the external analog input channel selection bits in the A/D Control Register together with the corresponding analog input pin function is selected. However, the additional function of the READ PORT mode is to force the A/D path to be switched on. For example, when the AN0 is selected as the analog input channel as the READ PORT function is enabled, the AN0 analog input path will be switched on even if the AN0 analog input pin function is not selected. In this way, the AN0 analog input path can be examined by internally connecting the digital output on this shared pin with the AN0 analog input pin switch and then converting the corresponding digital data without any external analog input voltage connected.

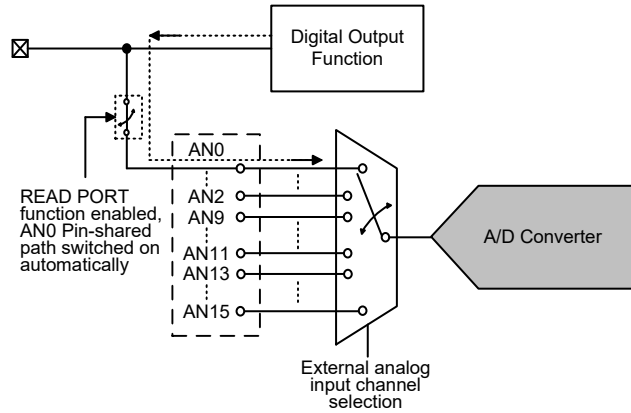

A/D Channel Input Path Internally Connection

Programming Considerations

Within the user program, one of the things first to consider is port initialisation. After a reset, all of the I/O data and port control registers will be set to high. This means that all I/O pins will be defaulted to an input state, the level of which depends on the other connected circuitry and whether pull-high selections have been chosen. If the port control registers are then programmed to setup some pins as outputs, these output pins will have an initial high output value unless the associated port data registers are first programmed. Selecting which pins are inputs and which are outputs can be achieved byte-wide by loading the correct values into the appropriate port control register or by programming individual bits in the port control register using the “SET [m].i” and “CLR [m].i” instructions. Note that when using these bit control instructions, a read-modify-write operation takes place. The microcontroller must first read in the data on the entire port, modify it to the required new bit values and then rewrite this data back to the output ports.

Port A has the additional capability of providing wake-up functions. When the device is in the SLEEP or IDLE Mode, various methods are available to wake the device up. One of these is a high to low transition of any of the Port A pins. Single or multiple pins on Port A can be setup to have this function.

Timer Modules – TM

One of the most fundamental functions in any microcontroller devices is the ability to control and measure time. To implement time related functions the device includes several Timer Modules, generally abbreviated to the name TM. The TMs are multi-purpose timing units and serve to provide operations such as Timer/Counter, Input Capture, Compare Match Output and Single Pulse Output as well as being the functional unit for the generation of PWM signals. Each of the TMs has two interrupts. The addition of input and output pins for TM ensures that users are provided with timing units with a wide and flexible range of features.

The common features of the different TM types are described here with more detailed information provided in the individual Standard and Periodic TM sections.

Introduction

The device contains several TM units and each individual TM can be categorised as a certain type, namely Standard Type TM or Periodic Type TM. Although similar in nature, the different TM types vary in their feature complexity. The common features to all of the Standard and Periodic Type TMs will be described in this section and the detailed operation regarding each of the TM types will be described in separate sections. The main features and differences between the two types of TMs are summarised in the accompanying table.

TM Function	STM	PTM
Timer/Counter	√	√
Input Capture	√	√
Compare Match Output	√	√
PWM Output	√	√
Single Pulse Output	√	√
PWM Alignment	Edge	Edge
PWM Adjustment Period & Duty	Duty or Period	Duty or Period

TM Function Summary

TM Operation

The TMs offer a diverse range of functions, from simple timing operations to PWM signal generation. The key to understanding how the TM operates is to see it in terms of a free running counter whose value is then compared with the value of pre-programmed internal comparator. When the free running counter has the same value as the pre-programmed comparator, known as a compare match situation, a TM interrupt signal will be generated which can clear the counter and perhaps also change the condition of the TM output pin. The internal TM counter is driven by a user selectable clock source, which can be an internal clock or an external pin.

TM Clock Source

The clock source which drives the main counter in the each TM can originate from various sources. The selection of the required clock source is implemented using the xTnCK2~xTnCK0 bits in the xTMn control registers, where “x” stands for S or P type TM and “n” stands for the specific TM serial number. The clock source can be a ratio of the system clock f_{SYS} or the internal high clock f_H , the f_{SUB} clock source or the external xTCKn pin. The xTCKn pin clock source is used to allow an external signal to drive the TM as an external clock source or for event counting.

TM Interrupts

Each of the Standard or Periodic type TM has two internal interrupts, the internal comparator A or comparator P, which generate a TM interrupt when a compare match condition occurs. When a TM interrupt is generated, it can be used to clear the counter and also to change the state of the TM output pin.

TM External Pins

Each of the TMs, irrespective of what type, has two TM input pins, with the label xTCKn and xTPnI, except that the STM0 has no external clock input pin. The xTMn input pin, xTCKn, is essentially a clock source for the xTMn and is selected using the xTnCK2~xTnCK0 bits in the xTMnC0 register. This external TM input pin allows an external clock source to drive the internal TM. The xTCKn input pin can be chosen to have either a rising or falling active edge. The xTCKn pin is also used as the external trigger input pin in single pulse output mode for the xTMn.

The other xTM input pin, STPnI or PTPnI, is the capture input whose active edge can be a rising edge, a falling edge or both rising and falling edges and the active edge transition type is selected using the STnIO1~STnIO0 or PTnIO1~PTnIO0 bits in the STMnC1 or PTMnC1 register. There is another capture input, PTCKn, for PTMn capture input mode, which can be used as the external trigger input source except the PTPnI pin.

The TMs each have one output pin with the label xTPn. When the TM is in the Compare Match Output Mode, these pins can be controlled by the TM to switch to a high or low level or to toggle when a compare match situation occurs. The external xTPn output pins is also the pins where the TM generates the PWM output waveform.

As the TM input/output pins are pin-shared with other functions, the TM input/output function must first be setup using relevant pin-shared function selection registers. The details of the pin-shared function selection are described in the pin-shared function section.

STM		PTM	
Input	Output	Input	Output
STP0I STCK1 STP1I	STP0 STP1	PTCK0, PTP0I PTCK1, PTP1I PTCK2, PTP2I PTCK3, PTP3I	PTP0 PTP1 PTP2 PTP3

TM External Pins

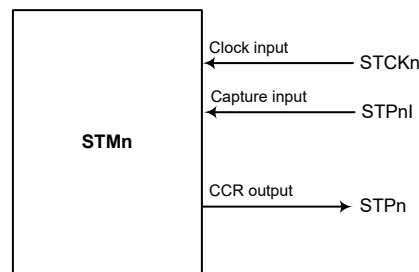

Note: STCKn is unavailable for the STM0.

STMn Function Pin Block Diagram (n=0~1)

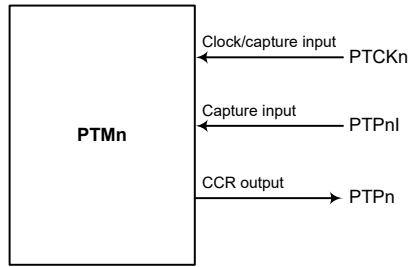

PTMn Function Pin Block Diagram (n=0~3)

Programming Considerations

The TM Counter Registers and the Capture/Compare CCRA and CCRP register, all have a low and high byte structure. The high bytes can be directly accessed, but as the low bytes can only be accessed via an internal 8-bit buffer, reading or writing to these register pairs must be carried out in a specific way. The important point to note is that data transfer to and from the 8-bit buffer and its related low byte only takes place when a write or read operation to its corresponding high byte is executed.

As the CCRA and CCRP registers are implemented in the way shown in the following diagram and accessing these register pairs is carried out in a specific way as described above, it is recommended to use the “MOV” instruction to access the CCRA and CCRP low byte registers, named xTMnAL and PTMnRPL, using the following access procedures. Accessing the CCRA or CCRP low byte registers without following these access procedures will result in unpredictable values.

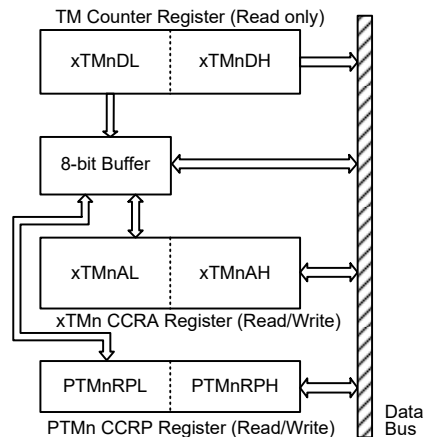

The following steps show the read and write procedures:

- Writing Data to CCRA or CCRP
 - ♦ Step 1. Write data to low byte xTMnAL or PTMnRPL
 - Note that here data is only written to the 8-bit buffer.
 - ♦ Step 2. Write data to high byte xTMnAH or PTMnRPH
 - Here data is written directly to the high byte registers and simultaneously data is latched from the 8-bit buffer to the low byte registers.
- Reading Data from the Counter Registers and CCRA or CCRP
 - ♦ Step 1. Read data from the high byte xTMnDH, xTMnAH or PTMnRPH
 - Here data is read directly from the high byte registers and simultaneously data is latched from the Low Byte register into the 8-bit buffer.
 - ♦ Step 2. Read data from the low byte xTMnDL, xTMnAL or PTMnRPL
 - This step reads data from the 8-bit buffer.

Standard Type TM – STM

The Standard Type TM contains five operating modes, which are Compare Match Output, Timer/Event Counter, Capture Input, Single Pulse Output and PWM Output modes. The Standard TM can also be controlled with two external input pins and can drive one external output pin.

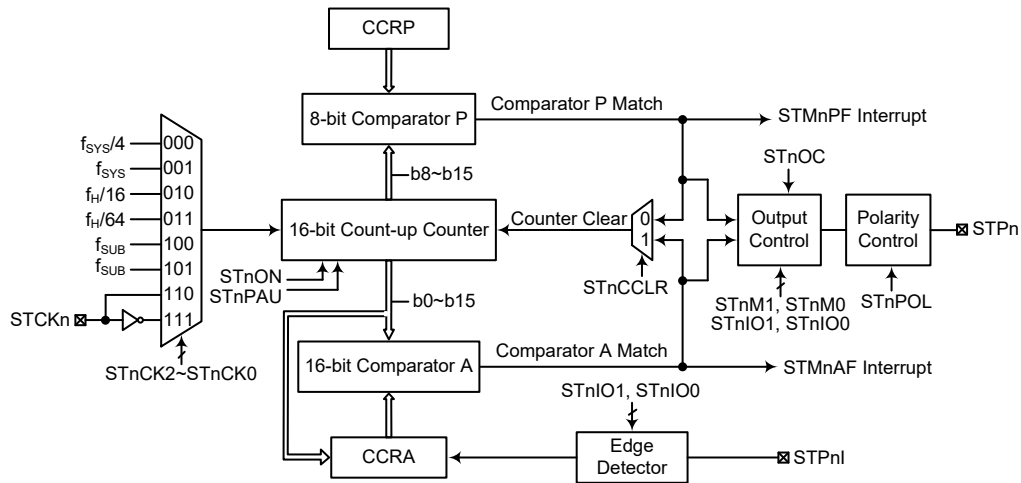

Note:1. The STMn external pins are pin-shared with other functions, so before using the STMn function the pin-shared function registers must be set properly to enable the STMn pin function.

2. STCKn is unavailable for the STM0.

Standard Type TM Block Diagram (n=0~1)

Standard TM Operation

The size of Standard TM is 16-bit wide and its core is a 16-bit count-up counter which is driven by a user selectable internal or external clock source. There are also two internal comparators with the names, Comparator A and Comparator P. These comparators will compare the value in the counter with CCRP and CCRA registers. The CCRP comparator is 8-bit wide whose value is compared the with highest 8 bits in the counter while the CCRA is the sixteen bits and therefore compares all counter bits.

The only way of changing the value of the 16-bit counter using the application program, is to clear the counter by changing the STnON bit from low to high. The counter will also be cleared automatically by a counter overflow or a compare match with one of its associated comparators. When these conditions occur, a STM interrupt signal will also usually be generated. The Standard Type TM can operate in a number of different operational modes, can be driven by different clock sources including an input pin and can also control an output pin. All operating setup conditions are selected using relevant internal registers.

Standard Type TM Register Description

Overall operation of the Standard TM is controlled using a series of registers. A read only register pair exists to store the internal counter 16-bit value, while a read/write register pair exists to store the internal 16-bit CCRA value. The STMnRP register is used to store the 8-bit CCRP value. The remaining two registers are control registers which setup the different operating and control modes.

Register Name	Bit							
	7	6	5	4	3	2	1	0
STMnC0	STnPAU	STnCK2	STnCK1	STnCK0	STnON	—	—	—
STMnC1	STnM1	STnM0	STnIO1	STnIO0	STnOC	STnPOL	STnDPX	STnCCLR
STMnDL	D7	D6	D5	D4	D3	D2	D1	D0
STMnDH	D15	D14	D13	D12	D11	D10	D9	D8
STMnAL	D7	D6	D5	D4	D3	D2	D1	D0
STMnAH	D15	D14	D13	D12	D11	D10	D9	D8
STMnRP	D7	D6	D5	D4	D3	D2	D1	D0

16-bit Standard TM Register List (n=0~1)

• **STMnDL Register**

Bit	7	6	5	4	3	2	1	0
Name	D7	D6	D5	D4	D3	D2	D1	D0
R/W	R	R	R	R	R	R	R	R
POR	0	0	0	0	0	0	0	0

Bit 7~0 STMn Counter Low Byte Register bit 7 ~ bit 0
 STMn 16-bit Counter bit 7 ~ bit 0

• **STMnDH Register**

Bit	7	6	5	4	3	2	1	0
Name	D15	D14	D13	D12	D11	D10	D9	D8
R/W	R	R	R	R	R	R	R	R
POR	0	0	0	0	0	0	0	0

Bit 7~0 STMn Counter High Byte Register bit 7 ~ bit 0
 STMn 16-bit Counter bit 15 ~ bit 8

• **STMnAL Register**

Bit	7	6	5	4	3	2	1	0
Name	D7	D6	D5	D4	D3	D2	D1	D0
R/W	R/W	R/W	R/W	R/W	R/W	R/W	R/W	R/W
POR	0	0	0	0	0	0	0	0

Bit 7~0 STMn CCRA Low Byte Register bit 7 ~ bit 0
 STMn 16-bit CCRA bit 7 ~ bit 0

• **STMnAH Register**

Bit	7	6	5	4	3	2	1	0
Name	D15	D14	D13	D12	D11	D10	D9	D8
R/W	R/W	R/W	R/W	R/W	R/W	R/W	R/W	R/W
POR	0	0	0	0	0	0	0	0

Bit 7~0 STMn CCRA High Byte Register bit 7 ~ bit 0
 STMn 16-bit CCRA bit 15 ~ bit 8

• STMnC0 Register

Bit	7	6	5	4	3	2	1	0
Name	STnPAU	STnCK2	STnCK1	STnCK0	STnON	—	—	—
R/W	R/W	R/W	R/W	R/W	R/W	—	—	—
POR	0	0	0	0	0	—	—	—

Bit 7 **STnPAU**: STMn Counter Pause control

0: Run
1: Pause

The counter can be paused by setting this bit high. Clearing the bit to zero restores normal counter operation. When in a Pause condition the STMn will remain powered up and continue to consume power. The counter will retain its residual value when this bit changes from low to high and resume counting from this value when the bit changes to a low value again.

Bit 6~4 **STnCK2~STnCK0**: Select STMn Counter clock

000: $f_{SYS}/4$
001: f_{SYS}
010: $f_H/16$
011: $f_H/64$
100: f_{SUB}
101: f_{SUB}
110: STCKn rising edge clock (unavailable for STM0)
111: STCKn falling edge clock (unavailable for STM0)

These three bits are used to select the clock source for the STMn. The external pin clock source can be chosen to be active on the rising or falling edge. The clock source f_{SYS} is the system clock, while f_H and f_{SUB} are other internal clocks, the details of which can be found in the oscillator section.

Bit 3 **STnON**: STMn Counter On/Off control

0: Off
1: On

This bit controls the overall on/off function of the STMn. Setting the bit high enables the counter to run while clearing the bit disables the STMn. Clearing this bit to zero will stop the counter from counting and turn off the STMn which will reduce its power consumption. When the bit changes state from low to high the internal counter value will be reset to zero, however when the bit changes from high to low, the internal counter will retain its residual value until the bit returns high again. If the STMn is in the Compare Match Output Mode, PWM Output Mode or Single Pulse Output Mode then the STMn output pin will be reset to its initial condition, as specified by the STnOC bit, when the STnON bit changes from low to high.

Bit 2~0 Unimplemented, read as “0”

• **STMnC1 Register**

Bit	7	6	5	4	3	2	1	0
Name	STnM1	STnM0	STnIO1	STnIO0	STnOC	STnPOL	STnDPX	STnCCLR
R/W	R/W	R/W	R/W	R/W	R/W	R/W	R/W	R/W
POR	0	0	0	0	0	0	0	0

- Bit 7~6 **STnM1~STnM0**: Select STMn Operating Mode
 00: Compare Match Output Mode
 01: Capture Input Mode
 10: PWM Output Mode or Single Pulse Output Mode
 11: Timer/Counter Mode

These bits setup the required operating mode for the STMn. To ensure reliable operation the STMn should be switched off before any changes are made to the STnM1 and STnM0 bits. In the Timer/Counter Mode, the STMn output pin state is undefined.

- Bit 5~4 **STnIO1~STnIO0**: Select STMn external pin STPn or STPnI function

- Compare Match Output Mode
 00: No change
 01: Output low
 10: Output high
 11: Toggle output
- PWM Output Mode/Single Pulse Output Mode
 00: PWM output inactive state
 01: PWM output active state
 10: PWM output
 11: Single Pulse Output
- Capture Input Mode
 00: Input capture at rising edge of STPnI
 01: Input capture at falling edge of STPnI
 10: Input capture at rising/falling edge of STPnI
 11: Input capture disabled

- Timer/Counter Mode
 Unused

These two bits are used to determine how the STMn external pin changes state when a certain condition is reached. The function that these bits select depends upon in which mode the STMn is running.

In the Compare Match Output Mode, the STnIO1 and STnIO0 bits determine how the STMn output pin changes state when a compare match occurs from the Comparator A. The TM output pin can be setup to switch high, switch low or to toggle its present state when a compare match occurs from the Comparator A. When the bits are both zero, then no change will take place on the output. The initial value of the STMn output pin should be setup using the STnOC bit in the STMnC1 register. Note that the output level requested by the STnIO1 and STnIO0 bits must be different from the initial value setup using the STnOC bit otherwise no change will occur on the STMn output pin when a compare match occurs. After the STMn output pin changes state, it can be reset to its initial level by changing the level of the STnON bit from low to high.

In the PWM Output Mode, the STnIO1 and STnIO0 bits determine how the STMn output pin changes state when a certain compare match condition occurs. The PWM output function is modified by changing these two bits. It is necessary to only change the values of the STnIO1 and STnIO0 bits only after the STMn has been switched off. Unpredictable PWM outputs will occur if the STnIO1 and STnIO0 bits are changed when the STMn is running.

- Bit 3** **STnOC:** STMn STPn Output control
Compare Match Output Mode
0: Initial low
1: Initial high
PWM Output Mode/Single Pulse Output Mode
0: Active low
1: Active high
This is the output control bit for the STMn output pin. Its operation depends upon whether STMn is being used in the Compare Match Output Mode or in the PWM Output Mode/Single Pulse Output Mode. It has no effect if the STMn is in the Timer/Counter Mode. In the Compare Match Output Mode it determines the logic level of the STMn output pin before a compare match occurs. In the PWM Output Mode/Single Pulse Output Mode it determines if the PWM signal is active high or active low.
- Bit 2** **STnPOL:** STMn STPn Output polarity control
0: Non-inverted
1: Inverted
This bit controls the polarity of the STPn output pin. When the bit is set high the STMn output pin will be inverted and not inverted when the bit is zero. It has no effect if the STMn is in the Timer/Counter Mode.
- Bit 1** **STnDPX:** STMn PWM duty/period control
0: CCRP – period; CCRA – duty
1: CCRP – duty; CCRA – period
This bit determines which of the CCRA and CCRP registers are used for period and duty control of the PWM waveform.
- Bit 0** **STnCCLR:** STMn Counter Clear condition selection
0: Comparator P match
1: Comparator A match
This bit is used to select the method which clears the counter. Remember that the Standard TM contains two comparators, Comparator A and Comparator P, either of which can be selected to clear the internal counter. With the STnCCLR bit set high, the counter will be cleared when a compare match occurs from the Comparator A. When the bit is low, the counter will be cleared when a compare match occurs from the Comparator P or with a counter overflow. A counter overflow clearing method can only be implemented if the CCRP bits are all cleared to zero. The STnCCLR bit is not used in the PWM Output, Single Pulse Output or Capture Input Mode.

• **STMnRP Register**

Bit	7	6	5	4	3	2	1	0
Name	D7	D6	D5	D4	D3	D2	D1	D0
R/W	R/W	R/W	R/W	R/W	R/W	R/W	R/W	R/W
POR	0	0	0	0	0	0	0	0

- Bit 7~0** **D7~D0:** STMn CCRP 8-bit register, compared with the STMn counter bit 15~bit 8
Comparator P match period=
0: 65536 STMn clocks
1~255: (1~255)×256 STMn clocks
These eight bits are used to setup the value on the internal CCRP 8-bit register, which are then compared with the internal counter's highest eight bits. The result of this comparison can be selected to clear the internal counter if the STnCCLR bit is set to zero. Setting the STnCCLR bit to zero ensures that a compare match with the CCRP values will reset the internal counter. As the CCRP bits are only compared with the highest eight counter bits, the compare values exist in 256 clock cycle multiples. Clearing all eight bits to zero is in effect allowing the counter to overflow at its maximum value.

Standard Type TM Operation Modes

The Standard Type TM can operate in one of five operating modes, Compare Match Output Mode, PWM Output Mode, Single Pulse Output Mode, Capture Input Mode or Timer/Counter Mode. The operating mode is selected using the STnM1 and STnM0 bits in the STMnC1 register.

Compare Match Output Mode

To select this mode, bits STnM1 and STnM0 in the STMnC1 register, should be set to 00 respectively. In this mode once the counter is enabled and running it can be cleared by three methods. These are a counter overflow, a compare match from Comparator A and a compare match from Comparator P. When the STnCCLR bit is low, there are two ways in which the counter can be cleared. One is when a compare match from Comparator P, the other is when the CCRP bits are all zero which allows the counter to overflow. Here both STMnAF and STMnPF interrupt request flags for Comparator A and Comparator P respectively, will both be generated.

If the STnCCLR bit in the STMnC1 register is high then the counter will be cleared when a compare match occurs from Comparator A. However, here only the STMnAF interrupt request flag will be generated even if the value of the CCRP bits is less than that of the CCRA registers. Therefore when STnCCLR is high no STMnPF interrupt request flag will be generated. In the Compare Match Output Mode, the CCRA can not be set to “0”.

If the CCRA bits are all zero, the counter will overflow when it reaches its maximum 16-bit, FFFF Hex, value, however here the STMnAF interrupt request flag will not be generated.

As the name of the mode suggests, after a comparison is made, the STMn output pin, will change state. The STMn output pin condition however only changes state when a STMnAF interrupt request flag is generated after a compare match occurs from Comparator A. The STMnPF interrupt request flag, generated from a compare match occurs from Comparator P, will have no effect on the STMn output pin. The way in which the STMn output pin changes state are determined by the condition of the STnIO1 and STnIO0 bits in the STMnC1 register. The STMn output pin can be selected using the STnIO1 and STnIO0 bits to go high, to go low or to toggle from its present condition when a compare match occurs from Comparator A. The initial condition of the STMn output pin, which is setup after the STnON bit changes from low to high, is setup using the STnOC bit. Note that if the STnIO1 and STnIO0 bits are zero then no pin change will take place.

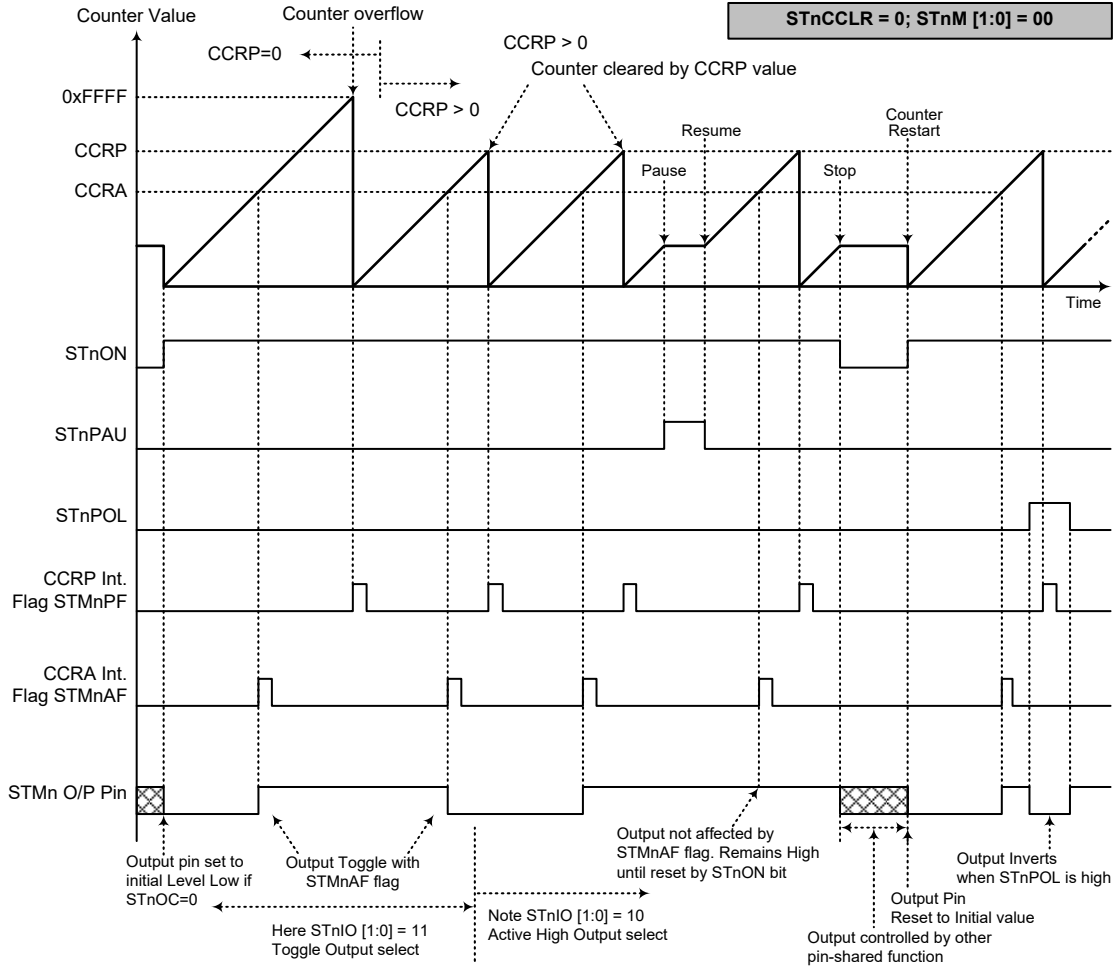

Compare Match Output Mode – STnCCLR=0

- Note: 1. With STnCCLR=0 a Comparator P match will clear the counter
2. The STMn output pin is controlled only by the STMnAF flag
3. The output pin is reset to its initial state by a STnON bit rising edge
4. n=0~1

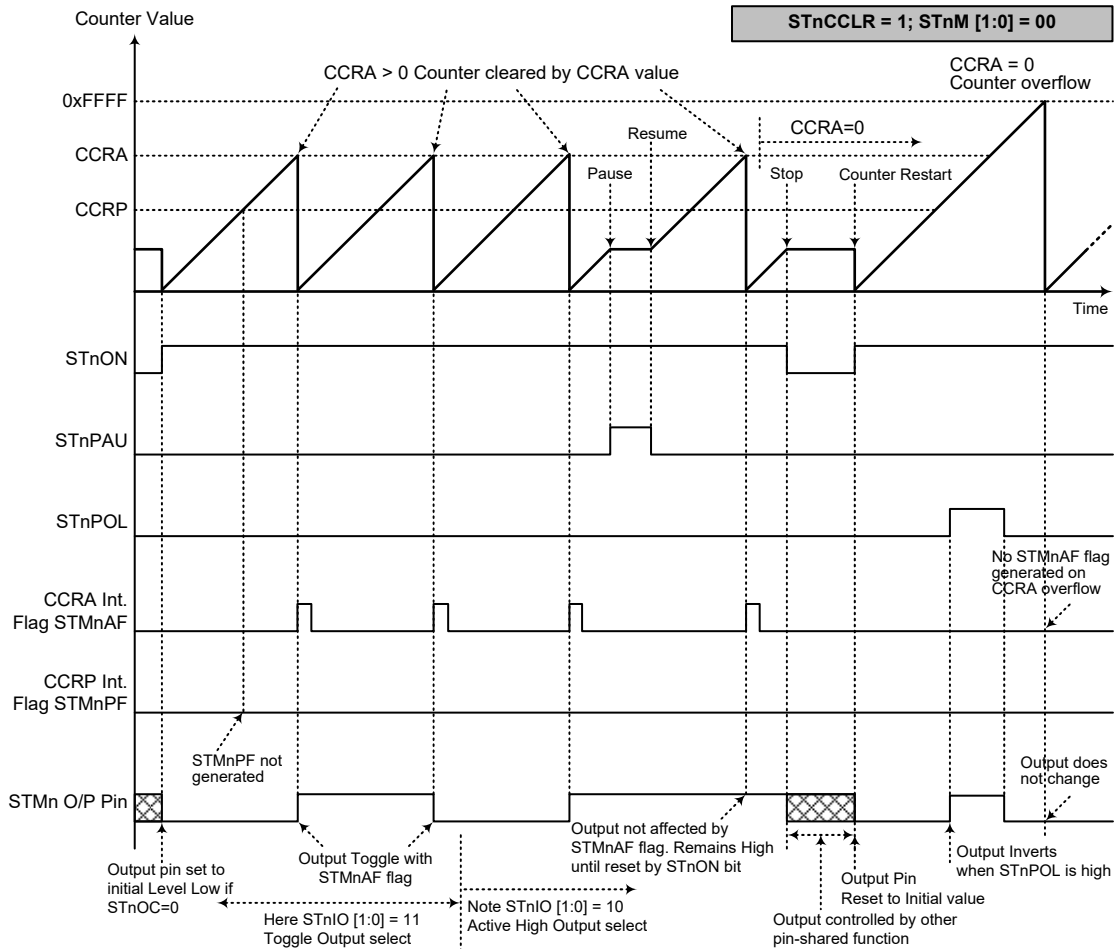

Compare Match Output Mode – STnCCR=1

- Note: 1. With STnCCR=1 a Comparator A match will clear the counter
2. The STMn output pin is controlled only by the STMnAF flag
3. The output pin is reset to its initial state by a STnON bit rising edge
4. A STMnPF flag is not generated when STnCCR=1
5. n=0~1

Timer/Counter Mode

To select this mode, bits STnM1 and STnM0 in the STMnC1 register should be set to 11 respectively. The Timer/Counter Mode operates in an identical way to the Compare Match Output Mode generating the same interrupt flags. The exception is that in the Timer/Counter Mode the STMn output pin is not used. Therefore the above description and Timing Diagrams for the Compare Match Output Mode can be used to understand its function. As the STMn output pin is not used in this mode, the pin can be used as a normal I/O pin or other pin-shared function.

PWM Output Mode

To select this mode, bits STnM1 and STnM0 in the STMnC1 register should be set to 10 respectively and also the STnIO1 and STnIO0 bits should be set to 10 respectively. The PWM function within the STMn is useful for applications which require functions such as motor control, heating control, illumination control etc. By providing a signal of fixed frequency but of varying duty cycle on the STMn output pin, a square wave AC waveform can be generated with varying equivalent DC RMS values.

As both the period and duty cycle of the PWM waveform can be controlled, the choice of generated waveform is extremely flexible. In the PWM Output Mode, the STnCCLR bit has no effect as the PWM period. Both of the CCRA and CCRP registers are used to generate the PWM waveform, one register is used to clear the internal counter and thus control the PWM waveform frequency, while the other one is used to control the duty cycle. Which register is used to control either frequency or duty cycle is determined using the STnDPX bit in the STMnC1 register. The PWM waveform frequency and duty cycle can therefore be controlled by the values in the CCRA and CCRP registers.

An interrupt flag, one for each of the CCRA and CCRP, will be generated when a compare match occurs from either Comparator A or Comparator P. The STnOC bit in the STMnC1 register is used to select the required polarity of the PWM waveform while the two STnIO1 and STnIO0 bits are used to enable the PWM output or to force the STMn output pin to a fixed high or low level. The STnPOL bit is used to reverse the polarity of the PWM output waveform.

• 16-bit STMn, PWM Output Mode, Edge-aligned Mode, STnDPX=0

CCRP	1~255	0
Period	CCRP×256	65536
Duty	CCRA	

If $f_{SYS}=16\text{MHz}$, STMn clock source is $f_{SYS}/4$, CCRP=2 and CCRA=128,

The STMn PWM output frequency= $(f_{SYS}/4)/(2\times 256)=f_{SYS}/2048=8\text{kHz}$, duty= $128/(2\times 256)=25\%$.

If the Duty value defined by the CCRA register is equal to or greater than the Period value, then the PWM output duty is 100%.

• 16-bit STMn, PWM Output Mode, Edge-aligned Mode, STnDPX=1

CCRP	1~255	0
Period	CCRA	
Duty	CCRP×256	65536

The PWM output period is determined by the CCRA register value together with the TM clock while the PWM duty cycle is defined by the CCRP register value except when the CCRP value is equal to 0.

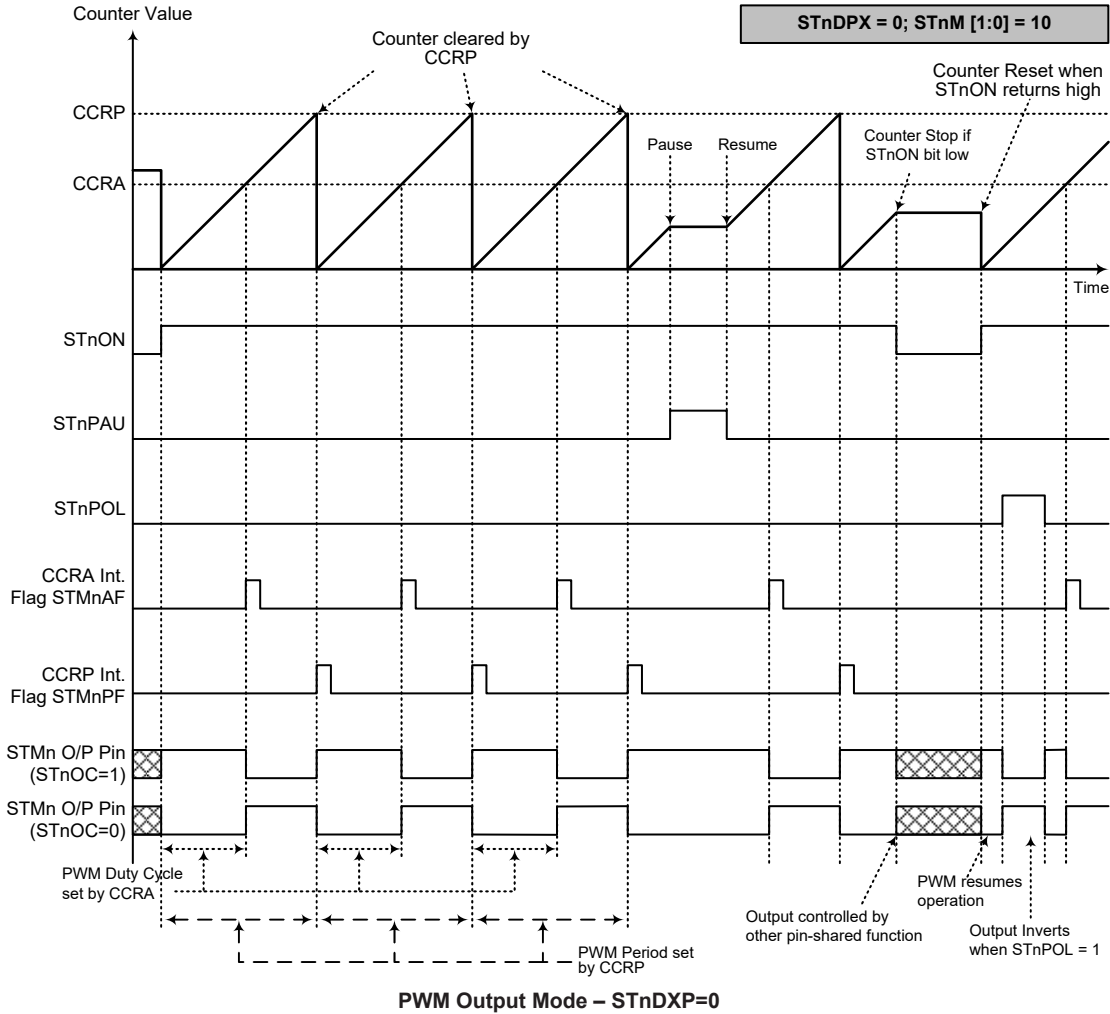

- Note: 1. Here STnDPX=0 – Counter cleared by CCRP
 2. A counter clear sets the PWM Period
 3. The internal PWM function continues running even when STnIO [1:0]=00 or 01
 4. The STnCCLR bit has no influence on PWM operation
 5. n=0~1

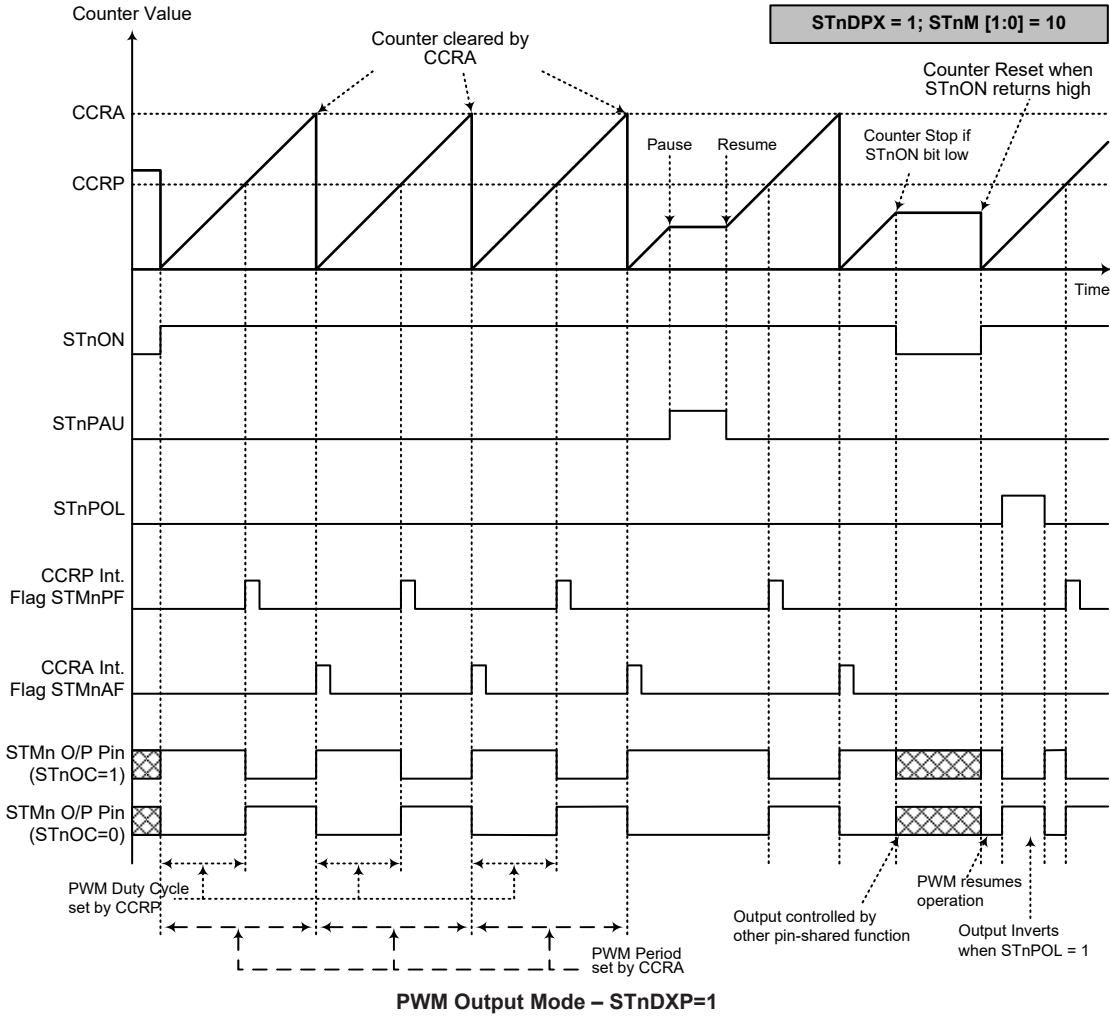

- Note: 1. Here STnDPX=1 – Counter cleared by CCRA
 2. A counter clear sets the PWM Period
 3. The internal PWM function continues even when STnIO [1:0]=00 or 01
 4. The STnCCLR bit has no influence on PWM operation
 5. n=0~1

Single Pulse Output Mode

To select this mode, bits STnM1 and STnM0 in the STMnC1 register should be set to 10 respectively and also the STnIO1 and STnIO0 bits should be set to 11 respectively. The Single Pulse Output Mode, as the name suggests, will generate a single shot pulse on the STMn output pin.

The trigger for the pulse output leading edge is a low to high transition of the STnON bit, which can be implemented using the application program. However in the Single Pulse Output Mode, the STnON bit can also be made to automatically change from low to high using the external STCKn pin, which will in turn initiate the Single Pulse output. When the STnON bit transitions to a high level, the counter will start running and the pulse leading edge will be generated. The STnON bit should remain high when the pulse is in its active state. The generated pulse trailing edge will be generated when the STnON bit is cleared to zero, which can be implemented using the application program or when a compare match occurs from Comparator A.

However a compare match from Comparator A will also automatically clear the STnON bit and thus generate the Single Pulse output trailing edge. In this way the CCRA value can be used to control the pulse width. A compare match from Comparator A will also generate a STMn interrupt. The counter can only be reset back to zero when the STnON bit changes from low to high when the counter restarts. In the Single Pulse Output Mode CCRP is not used. The STnCCLR and STnDPX bits are not used in this Mode.

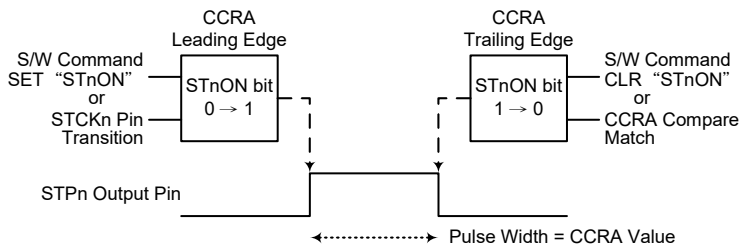

Note: STCKn is unavailable for the STM0.

Single Pulse Generation

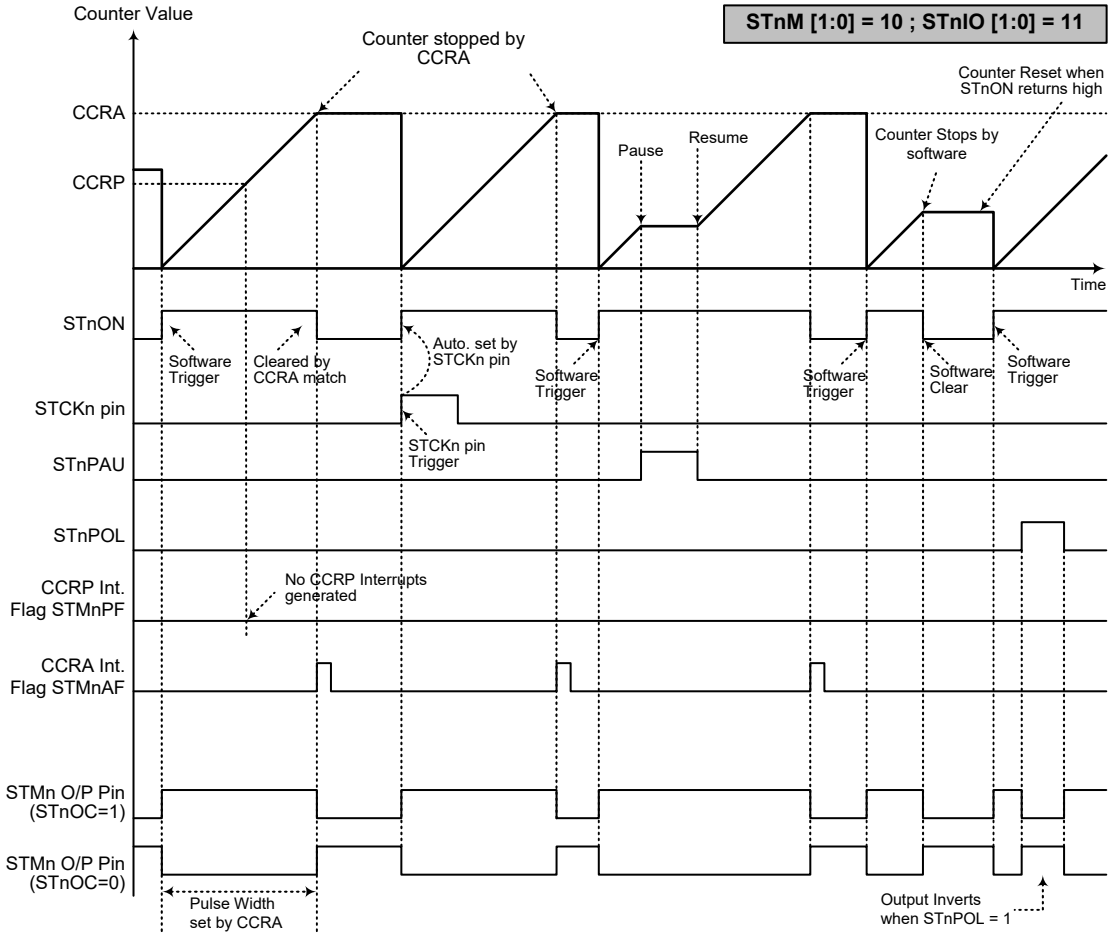

Single Pulse Output Mode

- Note:
1. Counter stopped by CCRA
 2. CCRP is not used
 3. The pulse triggered by the STCKn pin or by setting the STnON bit high
 4. A STCKn pin active edge will automatically set the STnON bit high
 5. In the Single Pulse Output Mode, STnIO [1:0] must be set to "11" and can not be changed
 6. n=0~1
 7. STCKn is unavailable for the STM0

Capture Input Mode

To select this mode bits STnM1 and STnM0 in the STMnC1 register should be set to 01 respectively. This mode enables external signals to capture and store the present value of the internal counter and can therefore be used for applications such as pulse width measurements. The external signal is supplied on the STPnI pin, whose active edge can be a rising edge, a falling edge or both rising and falling edges; the active edge transition type is selected using the STnIO1 and STnIO0 bits in the STMnC1 register. The counter is started when the STnON bit changes from low to high which is initiated using the application program.

When the required edge transition appears on the STPnI pin the present value in the counter will be latched into the CCRA registers and a STMn interrupt generated. Irrespective of what events occur on the STPnI pin the counter will continue to free run until the STnON bit changes from high to low. When a CCRP compare match occurs the counter will reset back to zero; in this way the CCRP value can be used to control the maximum counter value. When a CCRP compare match occurs from Comparator P, a STMn interrupt will also be generated. Counting the number of overflow interrupt signals from the CCRP can be a useful method in measuring long pulse widths. The STnIO1 and STnIO0 bits can select the active trigger edge on the STPnI pin to be a rising edge, falling edge or both edge types. If the STnIO1 and STnIO0 bits are both set high, then no capture operation will take place irrespective of what happens on the STPnI pin, however it must be noted that the counter will continue to run. The STnCCLR and STnDPX bits are not used in this Mode.

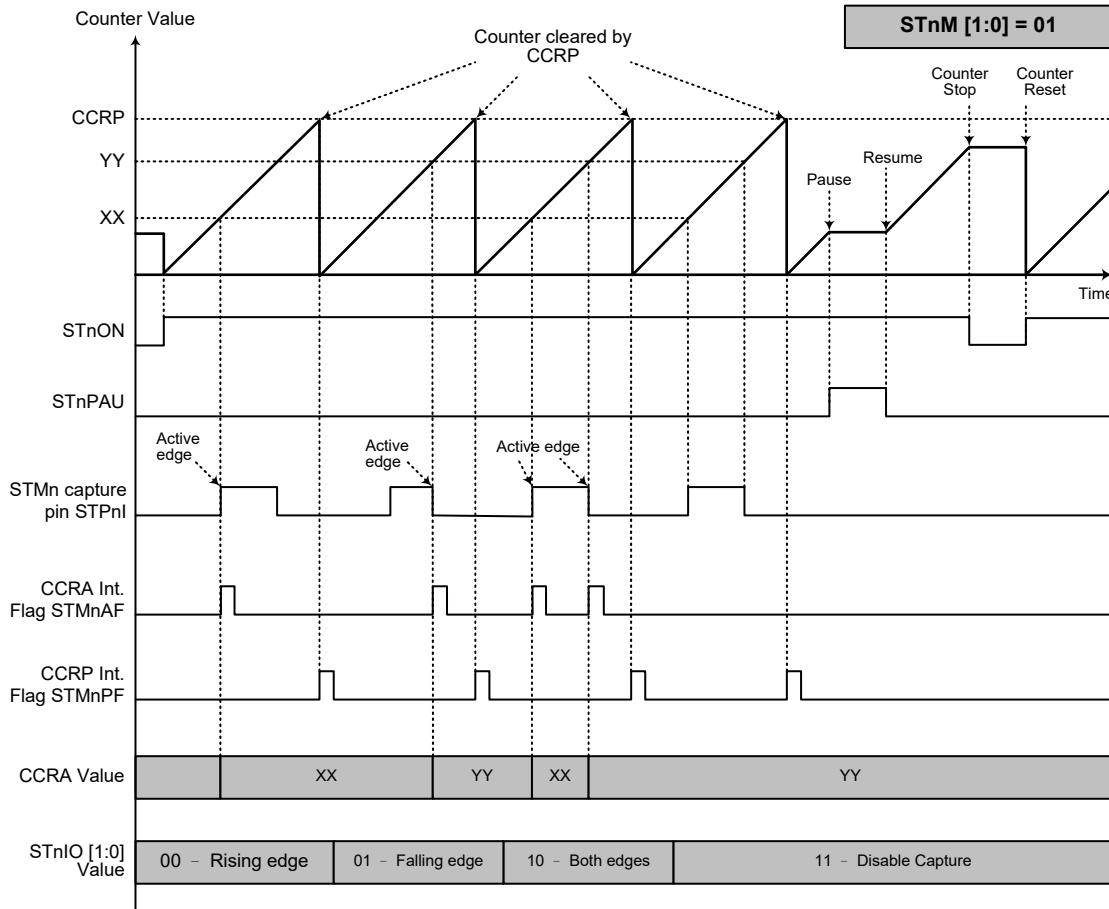

Capture Input Mode

- Note: 1. STnM [1:0]=01 and active edge set by the STnIO [1:0] bits
 2. A STMn Capture input pin active edge transfers the counter value to CCRA
 3. STnCCLR bit not used
 4. No output function – STnOC and STnPOL bits are not used
 5. CCRP determines the counter value and the counter has a maximum count value when CCRP is equal to zero
 6. n=0~1
 7. STCKn is unavailable for the STM0

Periodic Type TM – PTM

The Periodic Type TM contains five operating modes, which are Compare Match Output, Timer/Event Counter, Capture Input, Single Pulse Output and PWM Output modes. The Periodic TM can also be controlled with two external input pins and can drive one external output pin.

PTM Core	PTM Input Pin	PTM Output Pin
10-bit PTM (PTM0, PTM1)	PTCK0, PTP0I PTCK1, PTP1I	PTP0 PTP1
16-bit PTM (PTM2, PTM3)	PTCK2, PTP2I PTCK3, PTP3I	PTP2 PTP3

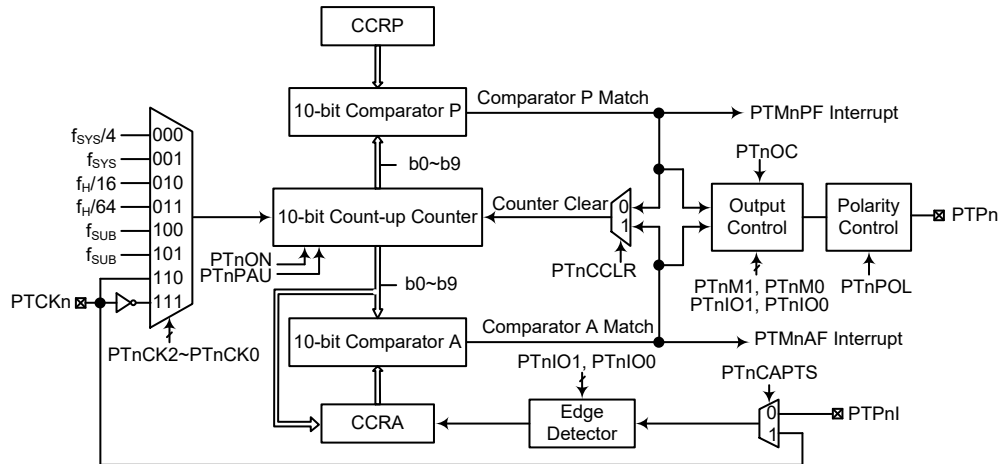

Note: The PTMn external pins are pin-shared with other functions, so before using the PTMn function the pin-shared function registers must be set properly to enable the PTMn pin function.

10-bit Periodic Type TM Block Diagram (n=0 or 1)

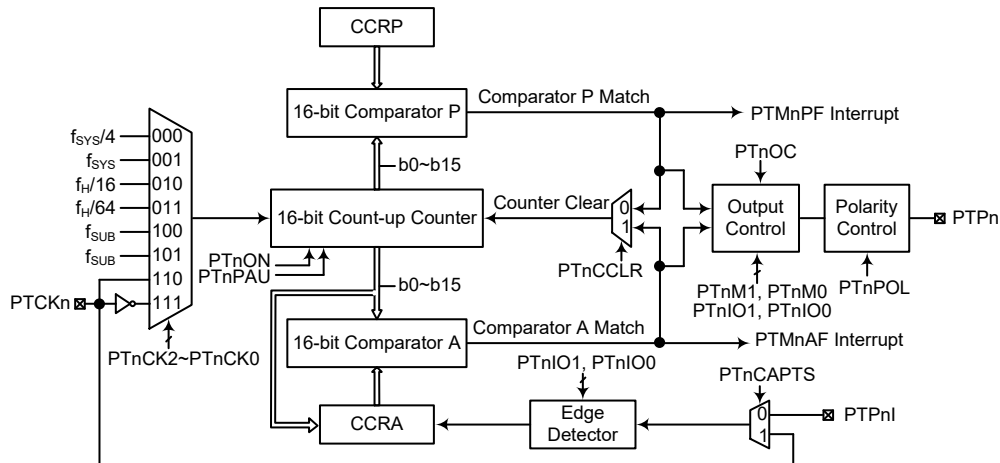

Note: The PTMn external pins are pin-shared with other functions, so before using the PTMn function the pin-shared function registers must be set properly to enable the PTMn pin function.

16-bit Periodic Type TM Block Diagram (n=2 or 3)

Periodic TM Operation

The size of Periodic TM is 10-/16-bit wide and its core is a 10-/16-bit count-up counter which is driven by a user selectable internal or external clock source. There are also two internal comparators with the names, Comparator A and Comparator P. These comparators will compare the value in the counter with CCRP and CCRA registers. The CCRP and CCRA comparators are 10-/16-bit wide whose value is respectively compared with all counter bits.

The only way of changing the value of the 10-/16-bit counter using the application program is to clear the counter by changing the PTnON bit from low to high. The counter will also be cleared automatically by a counter overflow or a compare match with one of its associated comparators. When these conditions occur, a PTM interrupt signal will also usually be generated. The Periodic Type TM can operate in a number of different operational modes, can be driven by different clock sources including an input pin and can also control the output pin. All operating setup conditions are selected using relevant internal registers.

Periodic Type TM Register Description

Overall operation of the Periodic TM is controlled using a series of registers. A read only register pair exists to store the internal counter 10-/16-bit value, while two read/write register pairs exist to store the internal 10-/16-bit CCRA and CCRP value. The remaining two registers are control registers which setup the different operating and control modes.

Register Name	Bit							
	7	6	5	4	3	2	1	0
PTMnC0	PTnPAU	PTnCK2	PTnCK1	PTnCK0	PTnON	—	—	—
PTMnC1	PTnM1	PTnM0	PTnIO1	PTnIO0	PTnOC	PTnPOL	PTnCAPTS	PTnCCLR
PTMnDL	D7	D6	D5	D4	D3	D2	D1	D0
PTMnDH	—	—	—	—	—	—	D9	D8
PTMnAL	D7	D6	D5	D4	D3	D2	D1	D0
PTMnAH	—	—	—	—	—	—	D9	D8
PTMnRPL	D7	D6	D5	D4	D3	D2	D1	D0
PTMnRPH	—	—	—	—	—	—	D9	D8

10-bit Periodic TM Register List (n=0 or 1)

Register Name	Bit							
	7	6	5	4	3	2	1	0
PTMnC0	PTnPAU	PTnCK2	PTnCK1	PTnCK0	PTnON	—	—	—
PTMnC1	PTnM1	PTnM0	PTnIO1	PTnIO0	PTnOC	PTnPOL	PTnCAPTS	PTnCCLR
PTMnDL	D7	D6	D5	D4	D3	D2	D1	D0
PTMnDH	D15	D14	D13	D12	D11	D10	D9	D8
PTMnAL	D7	D6	D5	D4	D3	D2	D1	D0
PTMnAH	D15	D14	D13	D12	D11	D10	D9	D8
PTMnRPL	D7	D6	D5	D4	D3	D2	D1	D0
PTMnRPH	D15	D14	D13	D12	D11	D10	D9	D8

16-bit Periodic TM Register List (n=2 or 3)

• **PTMnDL Register (n=0~3)**

Bit	7	6	5	4	3	2	1	0
Name	D7	D6	D5	D4	D3	D2	D1	D0
R/W	R	R	R	R	R	R	R	R
POR	0	0	0	0	0	0	0	0

Bit 7~0 PTMn Counter Low Byte Register bit 7 ~ bit 0
 PTMn 10-/16-bit Counter bit 7 ~ bit 0

• **PTMnDH Register (n=0~1)**

Bit	7	6	5	4	3	2	1	0
Name	—	—	—	—	—	—	D9	D8
R/W	—	—	—	—	—	—	R	R
POR	—	—	—	—	—	—	0	0

Bit 7~2 Unimplemented, read as “0”
 Bit 1~0 PTMn Counter High Byte Register bit 1 ~ bit 0
 PTMn 10-bit Counter bit 9 ~ bit 8

• **PTMnDH Register (n=2~3)**

Bit	7	6	5	4	3	2	1	0
Name	D15	D14	D13	D12	D11	D10	D9	D8
R/W	R	R	R	R	R	R	R	R
POR	0	0	0	0	0	0	0	0

Bit 7~0 PTMn Counter High Byte Register bit 7 ~ bit 0
 PTMn 16-bit Counter bit 15 ~ bit 8

• **PTMnAL Register (n=0~3)**

Bit	7	6	5	4	3	2	1	0
Name	D7	D6	D5	D4	D3	D2	D1	D0
R/W	R/W	R/W	R/W	R/W	R/W	R/W	R/W	R/W
POR	0	0	0	0	0	0	0	0

Bit 7~0 PTMn CCRA Low Byte Register bit 7 ~ bit 0
 PTMn 10-/16-bit CCRA bit 7 ~ bit 0

• **PTMnAH Register (n=0~1)**

Bit	7	6	5	4	3	2	1	0
Name	—	—	—	—	—	—	D9	D8
R/W	—	—	—	—	—	—	R/W	R/W
POR	—	—	—	—	—	—	0	0

Bit 7~2 Unimplemented, read as “0”
 Bit 1~0 PTMn CCRA High Byte Register bit 1 ~ bit 0
 PTMn 10-bit CCRA bit 9 ~ bit 8

• PTMnAH Register (n=2~3)

Bit	7	6	5	4	3	2	1	0
Name	D15	D14	D13	D12	D11	D10	D9	D8
R/W	R/W	R/W	R/W	R/W	R/W	R/W	R/W	R/W
POR	0	0	0	0	0	0	0	0

Bit 7~0 PTMn CCRA High Byte Register bit 7 ~ bit 0
 PTMn 16-bit CCRA bit 15 ~ bit 8

• PTMnRPL Register (n=0~3)

Bit	7	6	5	4	3	2	1	0
Name	D7	D6	D5	D4	D3	D2	D1	D0
R/W	R/W	R/W	R/W	R/W	R/W	R/W	R/W	R/W
POR	0	0	0	0	0	0	0	0

Bit 7~0 **D7~D0**: PTMn CCRP Low Byte Register bit 7 ~ bit 0
 PTMn 10-/16-bit CCRP bit 7 ~ bit 0

• PTMnRPH Register (n=0~1)

Bit	7	6	5	4	3	2	1	0
Name	—	—	—	—	—	—	D9	D8
R/W	—	—	—	—	—	—	R/W	R/W
POR	—	—	—	—	—	—	0	0

Bit 7~2 Unimplemented, read as “0”
 Bit 1~0 **D9~D8**: PTMn CCRP High Byte Register bit 1 ~ bit 0
 PTMn 10-bit CCRP bit 9 ~ bit 8

• PTMnRPH Register (n=2~3)

Bit	7	6	5	4	3	2	1	0
Name	D15	D14	D13	D12	D11	D10	D9	D8
R/W	R/W	R/W	R/W	R/W	R/W	R/W	R/W	R/W
POR	0	0	0	0	0	0	0	0

Bit 7~0 **D15~D8**: PTMn CCRP High Byte Register bit 7 ~ bit 0
 PTMn 16-bit CCRP bit 15 ~ bit 8

• PTMnC0 Register (n=0~3)

Bit	7	6	5	4	3	2	1	0
Name	PTnPAU	PTnCK2	PTnCK1	PTnCK0	PTnON	—	—	—
R/W	R/W	R/W	R/W	R/W	R/W	—	—	—
POR	0	0	0	0	0	—	—	—

Bit 7 **PTnPAU**: PTMn Counter Pause control
 0: Run
 1: Pause

The counter can be paused by setting this bit high. Clearing the bit to zero restores normal counter operation. When in a Pause condition the PTMn will remain powered up and continue to consume power. The counter will retain its residual value when this bit changes from low to high and resume counting from this value when the bit changes to a low value again.

Bit 6~4 **PTnCK2~PTnCK0**: Select PTMn Counter clock
 000: $f_{sys}/4$
 001: f_{sys}

- 010: $f_H/16$
- 011: $f_H/64$
- 100: f_{SUB}
- 101: f_{SUB}
- 110: PTCKn rising edge clock
- 111: PTCKn falling edge clock

These three bits are used to select the clock source for the PTMn. The external pin clock source can be chosen to be active on the rising or falling edge. The clock source f_{SYS} is the system clock, while f_H and f_{SUB} are other internal clocks, the details of which can be found in the oscillator section.

- Bit 3 **PTnON**: PTMn Counter On/Off control
- 0: Off
 - 1: On

This bit controls the overall on/off function of the PTMn. Setting the bit high enables the counter to run while clearing the bit disables the PTMn. Clearing this bit to zero will stop the counter from counting and turn off the PTMn which will reduce its power consumption. When the bit changes state from low to high the internal counter value will be reset to zero, however when the bit changes from high to low, the internal counter will retain its residual value until the bit returns high again. If the PTMn is in the Compare Match Output Mode, PWM Output Mode or Single Pulse Output Mode then the PTMn output pin will be reset to its initial condition, as specified by the PTnOC bit, when the PTnON bit changes from low to high.

- Bit 2~0 Unimplemented, read as “0”

• **PTMnC1 Register (n=0~3)**

Bit	7	6	5	4	3	2	1	0
Name	PTnM1	PTnM0	PTnIO1	PTnIO0	PTnOC	PTnPOL	PTnCAPTS	PTnCCLR
R/W	R/W	R/W	R/W	R/W	R/W	R/W	R/W	R/W
POR	0	0	0	0	0	0	0	0

- Bit 7~6 **PTnM1~PTnM0**: Select PTMn Operating Mode
- 00: Compare Match Output Mode
 - 01: Capture Input Mode
 - 10: PWM Output Mode or Single Pulse Output Mode
 - 11: Timer/Counter Mode

These bits setup the required operating mode for the PTMn. To ensure reliable operation the PTMn should be switched off before any changes are made to the PTnM1 and PTnM0 bits. In the Timer/Counter Mode, the PTMn output pin state is undefined.

- Bit 5~4 **PTnIO1~PTnIO0**: Select PTMn external pin PTPn, PTPnI or PTCKn function

Compare Match Output Mode

- 00: No change
- 01: Output low
- 10: Output high
- 11: Toggle output

PWM Output Mode/Single Pulse Output Mode

- 00: PWM output inactive state
- 01: PWM output active state
- 10: PWM output
- 11: Single Pulse Output

Capture Input Mode

- 00: Input capture at rising edge of PTPnI or PTCKn
- 01: Input capture at falling edge of PTPnI or PTCKn
- 10: Input capture at rising/falling edge of PTPnI or PTCKn
- 11: Input capture disabled

Timer/Counter Mode

Unused

These two bits are used to determine how the PTMn external pin changes state when a certain condition is reached. The function that these bits select depends upon in which mode the PTMn is running.

In the Compare Match Output Mode, the PTnIO1 and PTnIO0 bits determine how the PTMn output pin changes state when a compare match occurs from the Comparator A. The PTMn output pin can be setup to switch high, switch low or to toggle its present state when a compare match occurs from the Comparator A. When the bits are both zero, then no change will take place on the output. The initial value of the PTMn output pin should be setup using the PTnOC bit in the PTMnC1 register. Note that the output level requested by the PTnIO1 and PTnIO0 bits must be different from the initial value setup using the PTnOC bit otherwise no change will occur on the PTMn output pin when a compare match occurs. After the PTMn output pin changes state, it can be reset to its initial level by changing the level of the PTnON bit from low to high.

In the PWM Output Mode, the PTnIO1 and PTnIO0 bits determine how the TM output pin changes state when a certain compare match condition occurs. The PTMn output function is modified by changing these two bits. It is necessary to only change the values of the PTnIO1 and PTnIO0 bits only after the PTMn has been switched off. Unpredictable PWM outputs will occur if the PTnIO1 and PTnIO0 bits are changed when the PTMn is running.

Bit 3 **PTnOC**: PTMn PTPn Output control

Compare Match Output Mode

0: Initial low

1: Initial high

PWM Output Mode/Single Pulse Output Mode

0: Active low

1: Active high

This is the output control bit for the PTMn output pin. Its operation depends upon whether PTMn is being used in the Compare Match Output Mode or in the PWM Output Mode/Single Pulse Output Mode. It has no effect if the PTMn is in the Timer/Counter Mode. In the Compare Match Output Mode it determines the logic level of the PTMn output pin before a compare match occurs. In the PWM Output Mode/Single Pulse Output Mode it determines if the PWM signal is active high or active low.

Bit 2 **PTnPOL**: PTMn PTPn Output polarity control

0: Non-inverted

1: Inverted

This bit controls the polarity of the PTPn output pin. When the bit is set high the PTMn output pin will be inverted and not inverted when the bit is zero. It has no effect if the PTMn is in the Timer/Counter Mode.

Bit 1 **PTnCPTS**: PTMn Capture Trigger Source selection

0: From PTPnI pin

1: From PTCKn pin

Bit 0 **PTnCCLR**: PTMn Counter Clear condition selection

0: Comparator P match

1: Comparator A match

This bit is used to select the method which clears the counter. Remember that the Periodic TM contains two comparators, Comparator A and Comparator P, either of which can be selected to clear the internal counter. With the PTnCCLR bit set high, the counter will be cleared when a compare match occurs from the Comparator A. When the bit is low, the counter will be cleared when a compare match occurs from the Comparator P or with a counter overflow. A counter overflow clearing method can only be implemented if the CCRP bits are all cleared to zero. The PTnCCLR bit is not used in the PWM Output, Single Pulse Output or Capture Input Mode.

Periodic Type TM Operation Modes

The Periodic Type TM can operate in one of five operating modes, Compare Match Output Mode, PWM Output Mode, Single Pulse Output Mode, Capture Input Mode or Timer/Counter Mode. The operating mode is selected using the PTnM1 and PTnM0 bits in the PTMnC1 register.

Compare Match Output Mode

To select this mode, bits PTnM1 and PTnM0 in the PTMnC1 register, should be set to 00 respectively. In this mode once the counter is enabled and running it can be cleared by three methods. These are a counter overflow, a compare match from Comparator A and a compare match from Comparator P. When the PTnCCLR bit is low, there are two ways in which the counter can be cleared. One is when a compare match from Comparator P, the other is when the CCRP bits are all zero which allows the counter to overflow. Here both PTMnAF and PTMnPF interrupt request flags for Comparator A and Comparator P respectively, will both be generated.

If the PTnCCLR bit in the PTMnC1 register is high then the counter will be cleared when a compare match occurs from Comparator A. However, here only the PTMnAF interrupt request flag will be generated even if the value of the CCRP bits is less than that of the CCRA registers. Therefore when PTnCCLR is high no PTMnPF interrupt request flag will be generated. In the Compare Match Output Mode, the CCRA can not be set to "0".

If the CCRA bits are all zero, the counter will overflow when it reaches its maximum 10-bit, 3FF Hex, or 16-bit, FFFF Hex, value, however here the PTMnAF interrupt request flag will not be generated.

As the name of the mode suggests, after a comparison is made, the PTMn output pin will change state. The PTMn output pin condition however only changes state when a PTMnAF interrupt request flag is generated after a compare match occurs from Comparator A. The PTMnPF interrupt request flag, generated from a compare match occurs from Comparator P, will have no effect on the PTMn output pin. The way in which the PTMn output pin changes state are determined by the condition of the PTnIO1 and PTnIO0 bits in the PTMnC1 register. The PTMn output pin can be selected using the PTnIO1 and PTnIO0 bits to go high, to go low or to toggle from its present condition when a compare match occurs from Comparator A. The initial condition of the PTMn output pin, which is setup after the PTnON bit changes from low to high, is setup using the PTnOC bit. Note that if the PTnIO1 and PTnIO0 bits are zero then no pin change will take place.

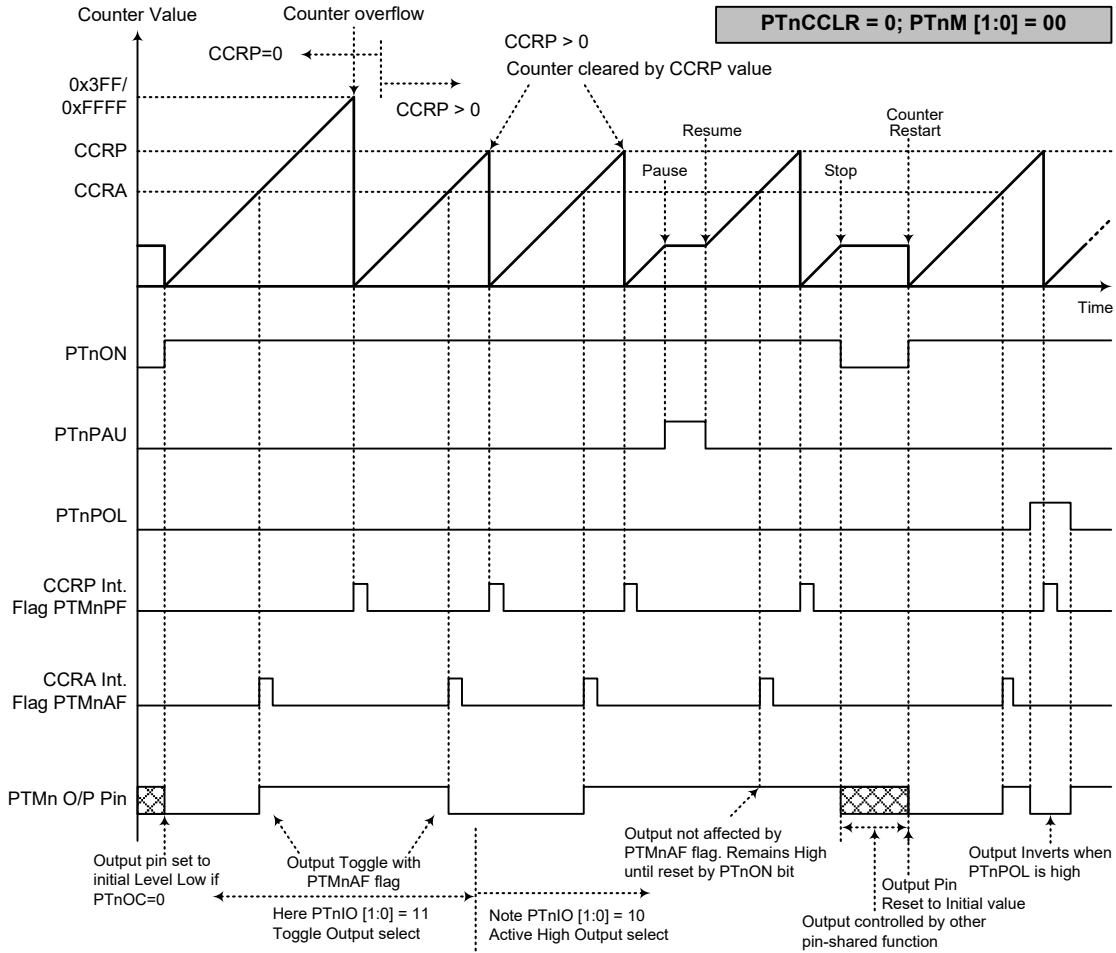

Compare Match Output Mode – PTnCCLR=0

- Note: 1. With PTnCCLR=0, a Comparator P match will clear the counter
2. The PTMn output pin is controlled only by the PTMnAF flag
3. The output pin is reset to its initial state by a PTnON bit rising edge
4. The 10-bit PTM maximum counter value is 0x3FF while the 16-bit PTM maximum counter value is 0xFFFF
5. n=0 or 1 for 10-bit PTM while n=2 or 3 for 16-bit PTM

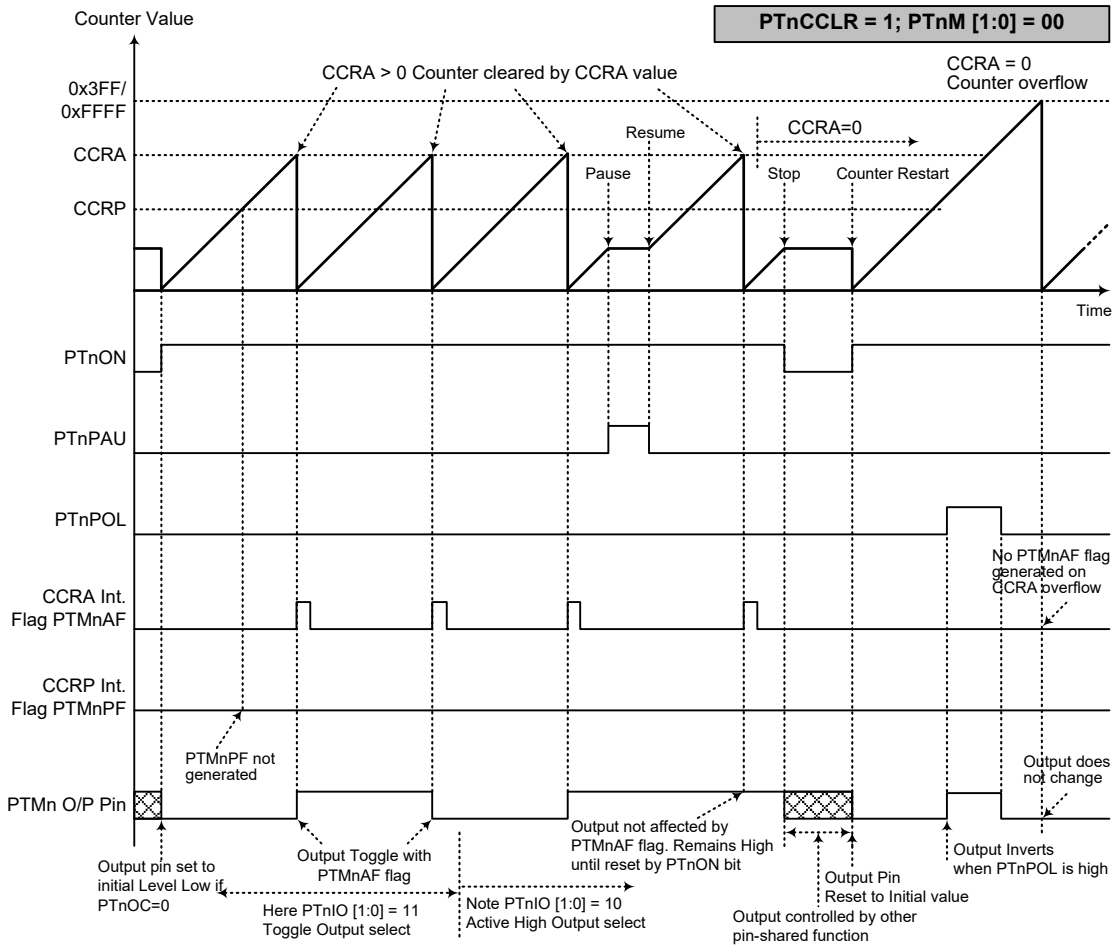

Compare Match Output Mode – PTnCCR=1

- Note: 1. With PTnCCR=1, a Comparator A match will clear the counter
2. The PTMn output pin is controlled only by the PTMnAF flag
3. The output pin is reset to its initial state by a PTnON bit rising edge
4. A PTMnPF flag is not generated when PTnCCR=1
5. The 10-bit PTM maximum counter value is 0x3FF while the 16-bit PTM maximum counter value is 0xFFFF
6. n=0 or 1 for 10-bit PTM while n=2 or 3 for 16-bit PTM

Timer/Counter Mode

To select this mode, bits PTnM1 and PTnM0 in the PTMnC1 register should be set to 11 respectively. The Timer/Counter Mode operates in an identical way to the Compare Match Output Mode generating the same interrupt flags. The exception is that in the Timer/Counter Mode the PTMn output pin is not used. Therefore the above description and Timing Diagrams for the Compare Match Output Mode can be used to understand its function. As the PTMn output pin is not used in this mode, the pin can be used as a normal I/O pin or other pin-shared function.

PWM Output Mode

To select this mode, bits PTnM1 and PTnM0 in the PTMnC1 register should be set to 10 respectively and also the PTnIO1 and PTnIO0 bits should be set to 10 respectively. The PWM function within the PTMn is useful for applications which require functions such as motor control, heating control, illumination control, etc. By providing a signal of fixed frequency but of varying duty cycle on the PTMn output pin, a square wave AC waveform can be generated with varying equivalent DC RMS values.

As both the period and duty cycle of the PWM waveform can be controlled, the choice of generated waveform is extremely flexible. In the PWM Output Mode, the PTnCCLR bit has no effect as the PWM period. Both of the CCRP and CCRA registers are used to generate the PWM waveform, one register is used to clear the internal counter and thus control the PWM waveform frequency, while the other one is used to control the duty cycle. The PWM waveform frequency and duty cycle can therefore be controlled by the values in the CCRA and CCRP registers.

An interrupt flag, one for each of the CCRA and CCRP, will be generated when a compare match occurs from either Comparator A or Comparator P. The PTnOC bit in the PTMnC1 register is used to select the required polarity of the PWM waveform while the two PTnIO1 and PTnIO0 bits are used to enable the PWM output or to force the PTMn output pin to a fixed high or low level. The PTnPOL bit is used to reverse the polarity of the PWM output waveform.

• 10-bit PTMn, PWM Output Mode, Edge-aligned Mode (n=0~1)

CCRP	1~1023	0
Period	1~1023	1024
Duty	CCRA	

• 16-bit PTMn, PWM Output Mode, Edge-aligned Mode (n=2~3)

CCRP	1~65535	0
Period	1~65535	65536
Duty	CCRA	

If $f_{SYS}=16\text{MHz}$, TM clock source select $f_{SYS}/4$, CCRP=512 and CCRA=128,

The PTMn PWM output frequency= $(f_{SYS}/4)/512=f_{SYS}/2048=8\text{kHz}$, duty= $128/512=25\%$,

If the Duty value defined by the CCRA register is equal to or greater than the Period value, then the PWM output duty is 100%.

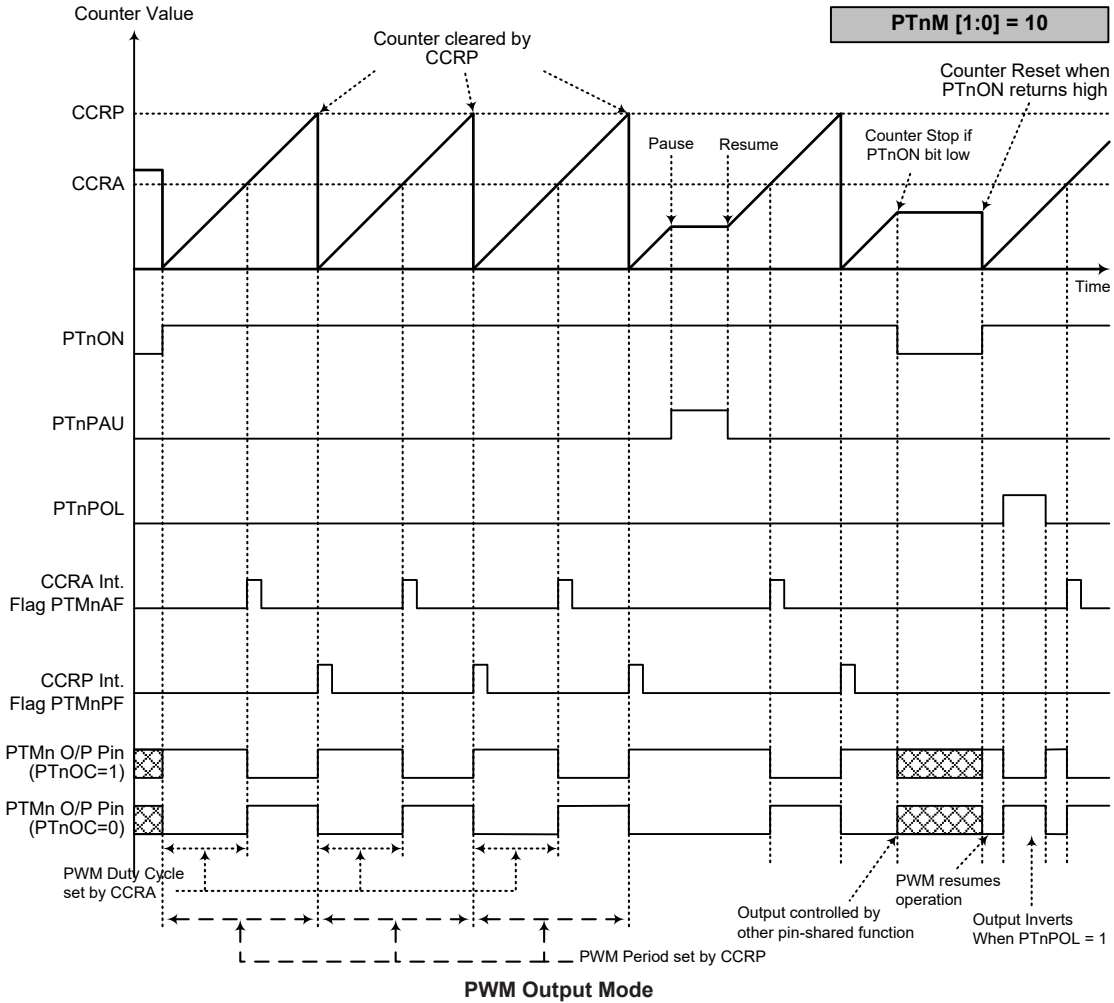

- Note:
1. The counter is cleared by CCRP
 2. A counter clear sets the PWM Period
 3. The internal PWM function continues running even when PTnIO [1:0]=00 or 01
 4. The PTnCCLR bit has no influence on PWM operation
 5. n=0 or 1 for 10-bit PTM while n=2 or 3 for 16-bit PTM

Single Pulse Output Mode

To select this mode, bits PTnM1 and PTnM0 in the PTMnC1 register should be set to 10 respectively and also the PTnIO1 and PTnIO0 bits should be set to 11 respectively. The Single Pulse Output Mode, as the name suggests, will generate a single shot pulse on the PTMn output pin.

The trigger for the pulse output leading edge is a low to high transition of the PTnON bit, which can be implemented using the application program. However in the Single Pulse Output Mode, the PTnON bit can also be made to automatically change from low to high using the external PTCKn pin, which will in turn initiate the Single Pulse output. When the PTnON bit transitions to a high level, the counter will start running and the pulse leading edge will be generated. The PTnON bit should remain high when the pulse is in its active state. The generated pulse trailing edge will be generated when the PTnON bit is cleared to zero, which can be implemented using the application program or when a compare match occurs from Comparator A.

However a compare match from Comparator A will also automatically clear the PTnON bit and thus generate the Single Pulse output trailing edge. In this way the CCRA value can be used to control the pulse width. A compare match from Comparator A will also generate a PTMn interrupt. The counter can only be reset back to zero when the PTnON bit changes from low to high when the counter restarts. In the Single Pulse Output Mode CCRP is not used. The PTnCCLR is not used in this Mode.

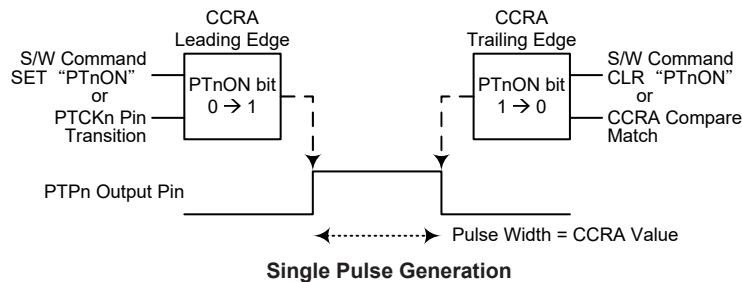

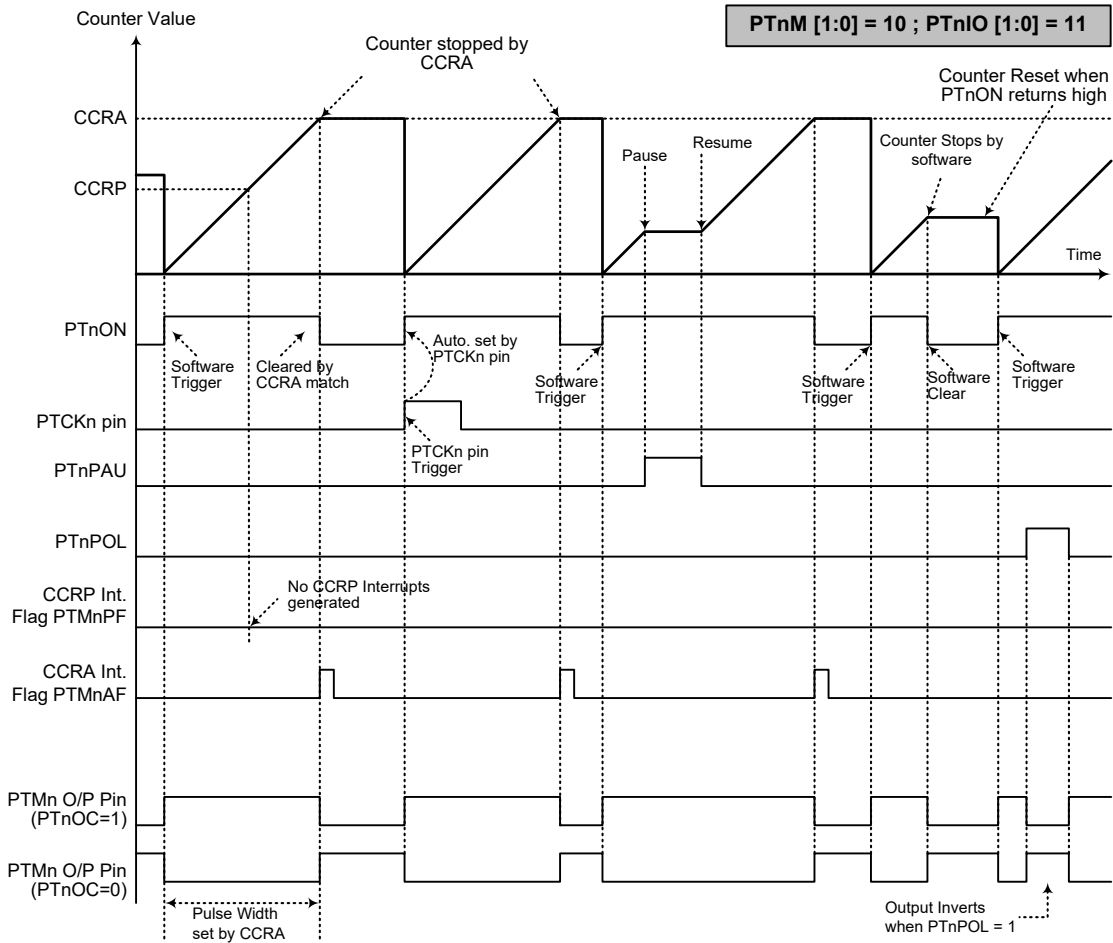

Single Pulse Output Mode

- Note:
1. Counter stopped by CCRA
 2. CCRP is not used
 3. The pulse triggered by the PTCKn pin or by setting the PTnON bit high
 4. A PTCKn pin active edge will automatically set the PTnON bit high
 5. In the Single Pulse Output Mode, PTnIO [1:0] must be set to "11" and can not be changed
 6. n=0 or 1 for 10-bit PTM while n=2 or 3 for 16-bit PTM

Capture Input Mode

To select this mode bits PTnM1 and PTnM0 in the PTMnC1 register should be set to 01 respectively. This mode enables external signals to capture and store the present value of the internal counter and can therefore be used for applications such as pulse width measurements. The external signal is supplied on the PTPnI or PTCKn pin, selected by the PTnCPTS bit in the PTMnC1 register. The input pin active edge can be either a rising edge, a falling edge or both rising and falling edges; the active edge transition type is selected using the PTnIO1 and PTnIO0 bits in the PTMnC1 register. The counter is started when the PTnON bit changes from low to high which is initiated using the application program.

When the required edge transition appears on the PTPnI or PTCKn pin the present value in the counter will be latched into the CCRA registers and a PTMn interrupt generated. Irrespective of what events occur on the PTPnI or PTCKn pin the counter will continue to free run until the PTnON bit changes from high to low. When a CCRP compare match occurs the counter will reset back to zero; in this way the CCRP value can be used to control the maximum counter value. When a CCRP compare match occurs from Comparator P, a PTMn interrupt will also be generated. Counting the number of overflow interrupt signals from the CCRP can be a useful method in measuring long pulse widths. The PTnIO1 and PTnIO0 bits can select the active trigger edge on the PTPnI or PTCKn pin to be a rising edge, falling edge or both edge types. If the PTnIO1 and PTnIO0 bits are both set high, then no capture operation will take place irrespective of what happens on the PTPnI or PTCKn pin, however it must be noted that the counter will continue to run.

As the PTPnI or PTCKn pin is pin shared with other functions, care must be taken if the PTMn is in the Input Capture Mode. This is because if the pin is setup as an output, then any transitions on this pin may cause an input capture operation to be executed. The PTnCCLR, PTnOC and PTnPOL bits are not used in this Mode.

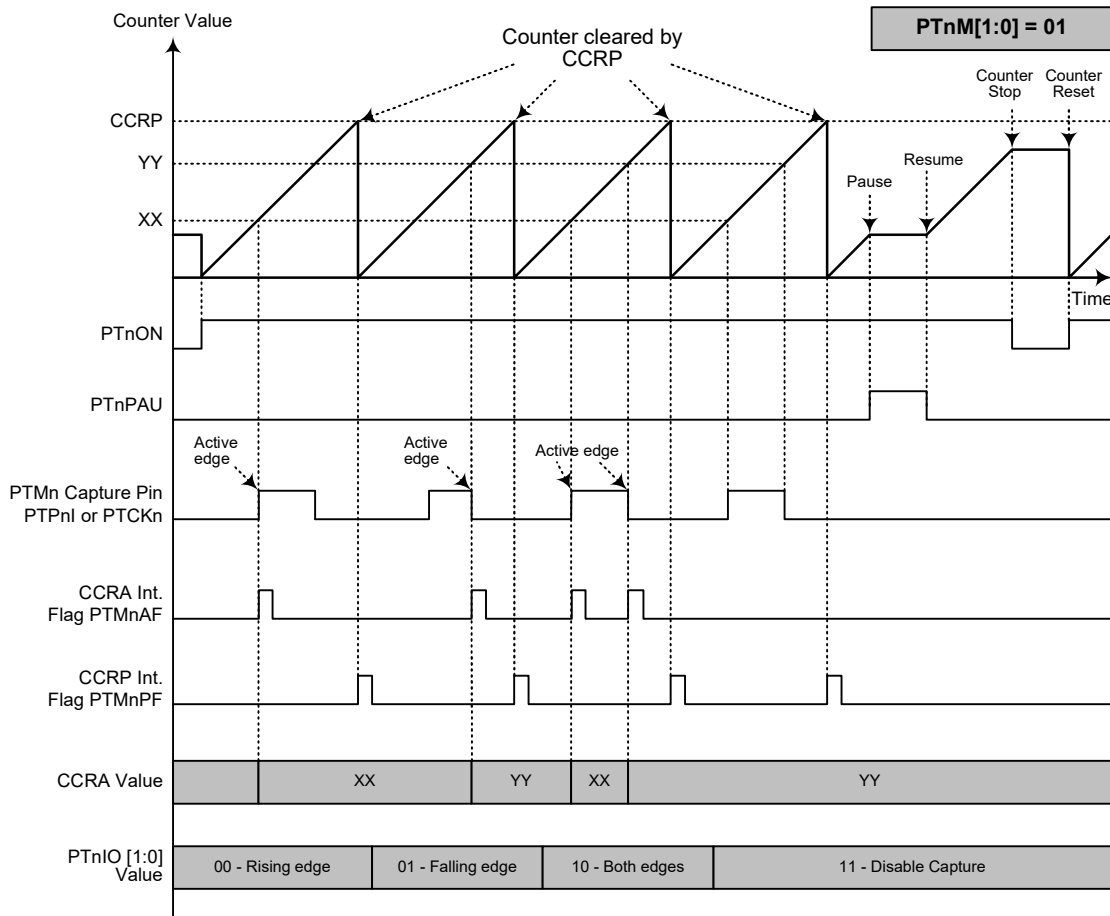

Capture Input Mode

- Note: 1. PTnM [1:0]=01 and active edge set by the PTnIO [1:0] bits
 2. A PTMn Capture input pin active edge transfers the counter value to CCRA
 3. PTnCCLR bit not used
 4. No output function – PTnOC and PTnPOL bits are not used
 5. CCRP determines the counter value and the counter has a maximum count value when CCRP is equal to zero
 6. n=0 or 1 for 10-bit PTM while n=2 or 3 for 16-bit PTM

12-Bit Analog to Digital Converter – ADC

The need to interface to real world analog signals is a common requirement for many electronic systems. However, to properly process these signals by a microcontroller, they must first be converted into digital signals by A/D converters. By integrating the A/D conversion electronic circuitry into the microcontroller, the need for external components is reduced significantly with the corresponding follow-on benefits of lower costs and reduced component space requirements.

A/D Converter Overview

The device contains a multi-channel analog to digital converter which can directly interface to external analog signals, such as that from sensors or other control signals and convert these signals directly into a 12-bit digital value. It also can convert the internal signals, such as the internal reference voltage, into a 12-bit digital value. The external or internal analog signal to be converted is determined by the SAINS and SACS bit fields. Note that when the internal analog signal is selected to be converted using the SAINS field, the external channel analog input will automatically be switched off. More detailed information about the A/D input signal selection will be described in the “A/D Converter Input Signals” section.

The accompanying block diagram shows the internal structure of the A/D converter with temperature sensor together with its associated registers and control bits.

External Input Channels	Internal Signal	A/D Signal Select
AN0~AN2, AN9~AN11, AN13~AN15	AV _{DD} , AV _{DD} /2, AV _{DD} /4, V _R , V _R /2, V _R /4,	SAINS3~SAINS0 SACS3~SACS0

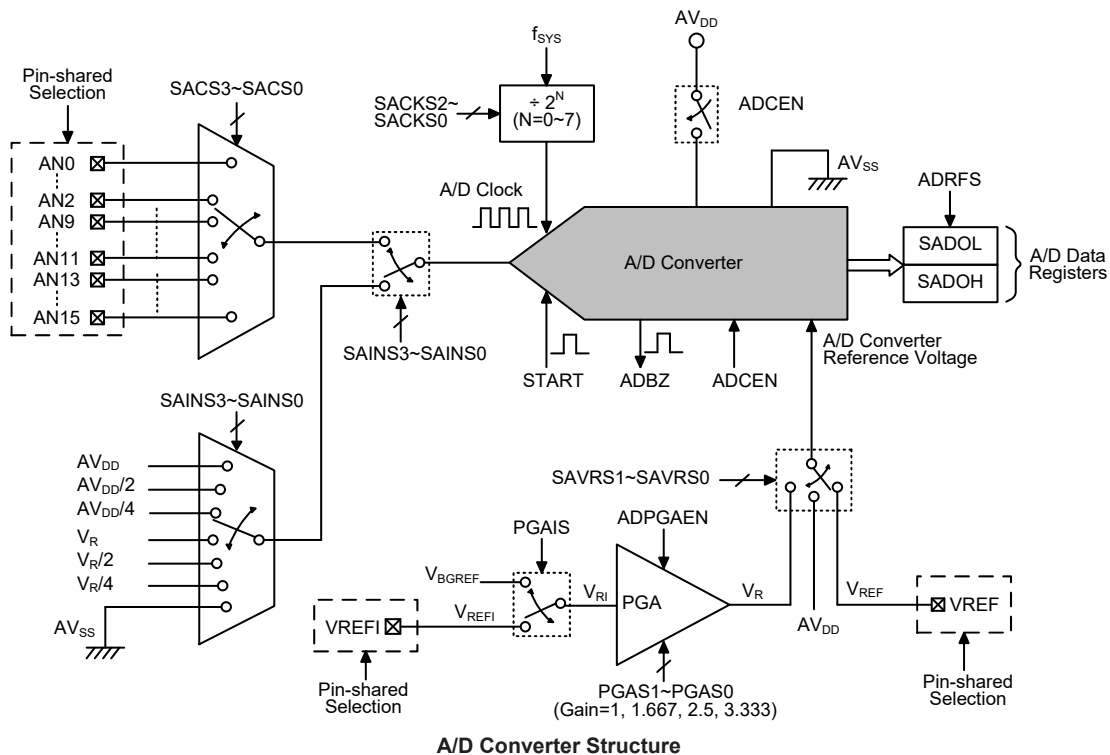

Registers Descriptions

Overall operation of the A/D converter is controlled using six registers. A read only register pair exists to store the A/D Converter data 12-bit value. Three registers, SADC0, SADC1 and SADC2, are the control registers which setup the operating conditions and control function of the A/D converter. The VBGRC register contains the VBGREN bit to control the bandgap reference voltage.

Register Name	Bit							
	7	6	5	4	3	2	1	0
SADOL (ADRF5=0)	D3	D2	D1	D0	—	—	—	—
SADOL (ADRF5=1)	D7	D6	D5	D4	D3	D2	D1	D0
SADOH (ADRF5=0)	D11	D10	D9	D8	D7	D6	D5	D4
SADOH (ADRF5=1)	—	—	—	—	D11	D10	D9	D8
SADC0	START	ADBZ	ADCEN	ADRF5	SACS3	SACS2	SACS1	SACS0
SADC1	SAINS3	SAINS2	SAINS1	SAINS0	—	SACKS2	SACKS1	SACKS0
SADC2	ADPGAEN	—	—	PGAIS	SAVRS1	SAVRS0	PGAGS1	PGAGS0
VBGRC	—	—	—	—	—	—	—	VBGREN

A/D Converter Register List

A/D Converter Data Registers – SADOL, SADOH

As the device contains an internal 12-bit A/D converter, it requires two data registers to store the converted value. These are a high byte register, known as SADOH, and a low byte register, known as SADOL. After the conversion process takes place, these registers can be directly read by the microcontroller to obtain the digitised conversion value. As only 12 bits of the 16-bit register space is utilised, the format in which the data is stored is controlled by the ADRFS bit in the SADC0 register as shown in the accompanying table. D0~D11 are the A/D conversion result data bits. Any unused bits will be read as zero. The A/D data registers contents will be unchanged if the A/D converter is disabled.

ADRF5	SADOH								SADOL							
	7	6	5	4	3	2	1	0	7	6	5	4	3	2	1	0
0	D11	D10	D9	D8	D7	D6	D5	D4	D3	D2	D1	D0	0	0	0	0
1	0	0	0	0	D11	D10	D9	D8	D7	D6	D5	D4	D3	D2	D1	D0

A/D Converter Data Registers

A/D Converter Control Registers – SADC0, SADC1, SADC2

To control the function and operation of the A/D converter, three control registers known as SADC0, SADC1 and SADC2 are provided. These 8-bit registers define functions such as the selection of which analog signal is connected to the internal A/D converter, the digitised data format, the A/D clock source as well as controlling the start function and monitoring the A/D converter busy status. As the device contains only one actual analog to digital converter hardware circuit, each of the external and internal analog signals must be routed to the converter. The SAINS field in the SADC1 register and SACS field in the SADC0 register are used to determine which analog signal derived from the external or internal signals will be connected to the A/D converter. The A/D converter also contains a programmable gain amplifier, PGA, to generate the A/D converter internal reference voltage. The overall operation of the PGA is controlled using the SADC2 register.

The relevant pin-shared function selection bits determine which pins on I/O Ports are used as analog inputs for the A/D converter input and which pins are not. When the pin is selected to be an A/D input, its original function whether it is an I/O or other pin-shared function will be removed. In addition, any internal pull-high resistor connected to the pin will be automatically removed if the pin is selected to be an A/D converter input.

• SADC0 Register

Bit	7	6	5	4	3	2	1	0
Name	START	ADBZ	ADCEN	ADRFS	SACS3	SACS2	SACS1	SACS0
R/W	R/W	R	R/W	R/W	R/W	R/W	R/W	R/W
POR	0	0	0	0	0	0	0	0

- Bit 7 **START**: Start the A/D Conversion
0→1→0: Start
This bit is used to initiate an A/D conversion process. The bit is normally low but if set high and then cleared low again, the A/D converter will initiate a conversion process.
- Bit 6 **ADBZ**: A/D Converter busy flag
0: No A/D conversion is in progress
1: A/D conversion is in progress
This read only flag is used to indicate whether the A/D conversion is in progress or not. When the START bit is set from low to high and then to low again, the ADBZ flag will be set to 1 to indicate that the A/D conversion is initiated. The ADBZ flag will be cleared to 0 after the A/D conversion is complete.
- Bit 5 **ADCEN**: A/D Converter function enable control
0: Disable
1: Enable
This bit controls the A/D internal function. This bit should be set to one to enable the A/D converter. If the bit is set low, then the A/D converter will be switched off reducing the device power consumption. When the A/D converter function is disabled, the contents of the A/D data register pair known as ADRH and ADRL will be unchanged.
- Bit 4 **ADRFS**: A/D conversion data format select
0: A/D converter data format → SADOH=D [11:4]; SADOL=D [3:0]
1: A/D converter data format → SADOH=D [11:8]; SADOL=D [7:0]
This bit controls the format of the 12-bit converted A/D value in the two A/D data registers. Details are provided in the A/D converter data register section.
- Bit 3~0 **SACS3~SACS0**: A/D converter external analog input channel select
0000: External AN0 input
0001: External AN1 input
0010: External AN2 input
0011: Reserved, cannot be used
0100: Reserved, cannot be used
0101: Reserved, cannot be used
0110: Reserved, cannot be used
0111: Reserved, cannot be used
1000: Reserved, cannot be used
1001: External AN9 input
1010: External AN10 input
1011: External AN11 input
1100: Reserved, cannot be used
1101: External AN13 input
1110: External AN14 input
1111: External AN15 input

• **SADC1 Register**

Bit	7	6	5	4	3	2	1	0
Name	SAINS3	SAINS2	SAINS1	SAINS0	—	SACKS2	SACKS1	SACKS0
R/W	R/W	R/W	R/W	R/W	—	R/W	R/W	R/W
POR	0	0	0	0	—	0	0	0

- Bit 7~4 **SAINS3~SAINS0**: A/D converter input signal select
 0000: External source – External analog channel input, ANn
 0001: Internal source – Internal signal derived from AV_{DD}
 0010: Internal source – Internal signal derived from AV_{DD}/2
 0011: Internal source – Internal signal derived from AV_{DD}/4
 0100: External source – External analog channel input, ANn
 0101: Internal source – Internal signal derived from PGA output V_R
 0110: Internal source – Internal signal derived from PGA output V_R/2
 0111: Internal source – Internal signal derived from PGA output V_R/4
 10xx: Internal source – Ground
 11xx: External source – External analog channel input, ANn

When the internal analog signal is selected to be converted, the external channel signal input will automatically be switched off regardless of the SACKS field value. It will prevent the external channel input from being connected together with the internal analog signal.

- Bit 3 Unimplemented, read as “0”
- Bit 2~0 **SACKS2~SACKS0**: A/D conversion clock source select
 000: f_{sys}
 001: f_{sys}/2
 010: f_{sys}/4
 011: f_{sys}/8
 100: f_{sys}/16
 101: f_{sys}/32
 110: f_{sys}/64
 111: f_{sys}/128

• **SADC2 Register**

Bit	7	6	5	4	3	2	1	0
Name	ADPGAEN	—	—	PGAIS	SAVRS1	SAVRS0	PGAGS1	PGAGS0
R/W	R/W	—	—	R/W	R/W	R/W	R/W	R/W
POR	0	—	—	0	0	0	0	0

- Bit 7 **ADPGAEN**: PGA enable control
 0: Disable
 1: Enable
- Bit 6~5 Unimplemented, read as “0”
- Bit 4 **PGAIS**: PGA input voltage selection
 0: From VREFI pin
 1: From internal reference voltage V_{BGREF}
 When the internal independent reference voltage V_{BGREF} is selected as the PGA input, the external reference voltage on the VREFI pin will be automatically switched off. In addition, the internal bandgap reference V_{BGREF} should be enabled by setting the VBGREN bit in the VBGRC register to “1”.
- Bit 3~2 **SAVRS1~SAVRS0**: A/D converter reference voltage select
 00: Internal A/D converter power, AV_{DD}
 01: External VREF pin
 1x: Internal PGA output voltage, V_R

These bits are used to select the A/D converter reference voltage source. When the internal reference voltage source is selected, the reference voltage derived from the external VREF pin will automatically be switched off.

- Bit 1~0 **PGAGS1~PGAGS0**: PGA gain select
 00: Gain=1
 01: Gain=1.667 – $V_R=2V$ as $V_{RI}=1.2V$
 10: Gain=2.5 – $V_R=3V$ as $V_{RI}=1.2V$
 11: Gain=3.333 – $V_R=4V$ as $V_{RI}=1.2V$

These bits are used to select the PGA gain. Note that here the gain is guaranteed only when the PGA input voltage is equal to 1.2V.

• VBGRC Register

Bit	7	6	5	4	3	2	1	0
Name	—	—	—	—	—	—	—	VBGREN
R/W	—	—	—	—	—	—	—	R/W
POR	—	—	—	—	—	—	—	0

- Bit 7~1 Unimplemented, read as “0”
 Bit 0 **VBGREN**: Bandgap reference voltage control
 0: Disable
 1: Enable

This bit is used to enable the internal Bandgap reference circuit. The internal Bandgap reference circuit should first be enabled before the V_{BGMREF} voltage is selected to be used. A specific start-up time is necessary for the Bandgap circuit to become stable and accurate.

A/D Converter Reference Voltage

The actual reference voltage supply to the A/D Converter can be supplied from the positive power supply, AV_{DD} , an external reference source supplied on pin VREF or an internal reference voltage V_R determined by the SAVRS1~SAVRS0 bits in the SADC2 register. The internal reference voltage is amplified through a programmable gain amplifier, PGA, which is controlled by the ADPGAEN bit in the SADC2 register. The PGA gain can be equal to 1, 1.667, 2.5 or 3.333 and selected using the PGAGS1~PGAGS0 bits in the SADC2 register. The PGA input can come from the external reference input pin, VREFI, or an internal Bandgap reference voltage, V_{BGMREF} , selected by the PGASIS bit in the SADC2 register. As the VREFI and VREF pins both are pin-shared with other functions, when the VREFI or VREF pin is selected as the reference voltage pin, the VREFI or VREF pin-shared function selection bits should first be properly configured to disable other pin-shared functions. However, if the internal reference signal is selected as the reference source, the external reference input from the VREFI or VREF pin will automatically be switched off by hardware.

Note that the internal Bandgap reference circuit should first be enabled before the V_{BGMREF} is selected to be used. A specific start-up time is necessary for the Bandgap circuit to become stable and accurate.

A/D Converter Input Signals

All of the external A/D analog input pins are pin-shared with the I/O pins as well as other functions. The corresponding pin-shared function selection bits in the PxS1 and PxS0 registers, determine whether the external input pins are setup as A/D converter analog channel inputs or whether they have other functions. If the corresponding pin is setup to be an A/D converter analog channel input, the original pin function will be disabled. In this way, pins can be changed under program control to change their function between A/D inputs and other functions. All pull-high resistors, which are setup through register programming, will be automatically disconnected if the pins are setup as A/D

inputs. Note that it is not necessary to first setup the A/D pin as an input in the port control register to enable the A/D input as when the relevant A/D input function selection bits enable an A/D input, the status of the port control register will be overridden.

As the device contains only one actual analog to digital converter hardware circuit, each of the external and internal analog signals must be routed to the converter. The SAINS3~SAINS0 bits in the SADC1 register are used to determine that the analog signal to be converted comes from the external channel input or internal analog signal. The SACS3~SACS0 bits in the SADC0 register are used to determine which external channel input is selected to be converted. If the SAINS3~SAINS0 bits are set to “0000”, the external channel input will be selected to be converted and the SACS3~SACS0 bits can determine which external channel is selected.

When the SAINS field is set to the value of “0x01”, “0x10” or “0x11”, the internal analog signal will be selected. If the internal analog signal is selected to be converted, the external channel signal input will automatically be switched off regardless of the SACS field value. It will prevent the external channel input from being connected together with the internal analog signal.

SAINS [3:0]	SACS [3:0]	Input Signals	Description
0000, 0100, 11xx	0000~0010, 1001~1011, 1101~1111	0000~0010, 1001~1011, 1101~1111	External channel analog input ANn
0001	xxxx	AV _{DD}	Internal signal derived from AV _{DD}
0010	xxxx	AV _{DD} /2	Internal signal derived from AV _{DD} /2
0011	xxxx	AV _{DD} /4	Internal signal derived from AV _{DD} /4
0101	xxxx	V _R	Internal signal derived from PGA output V _R
0110	xxxx	V _R /2	Internal signal derived from PGA output V _R /2
0111	xxxx	V _R /4	Internal signal derived from PGA output V _R /4
10xx	xxxx	AV _{SS}	Connected to the ground

A/D Converter Input Signal Selection

A/D Conversion Operation

The START bit in the SADC0 register is used to start the AD conversion. When the microcontroller sets this bit from low to high and then low again, an analog to digital conversion cycle will be initiated.

The ADBZ bit in the SADC0 register is used to indicate whether the analog to digital conversion process is in progress or not. This bit will be automatically set to 1 by the microcontroller after an A/D conversion is successfully initiated. When the A/D conversion is complete, the ADBZ bit will be cleared to 0. In addition, the corresponding A/D interrupt request flag will be set in the interrupt control register, and if the interrupts are enabled, an internal interrupt signal will be generated. This A/D internal interrupt signal will direct the program flow to the associated A/D internal interrupt address for processing. If the A/D internal interrupt is disabled, the microcontroller can poll the ADBZ bit in the SADC0 register to check whether it has been cleared as an alternative method of detecting the end of an A/D conversion cycle.

The clock source for the A/D converter, which originates from the system clock f_{SYS} , can be chosen to be either f_{SYS} or a subdivided version of f_{SYS} . The division ratio value is determined by the SACKS2~SACKS0 bits in the SADC1 register. Although the A/D clock source is determined by the system clock f_{SYS} and by bits SACKS2~SACKS0, there are some limitations on the maximum A/D clock source speed that can be selected. As the recommended range of permissible A/D clock period, t_{ADCK} , is from 0.5 μ s to 10 μ s, @2.0V \leq V_{DD} \leq 5.5V, care must be taken for system clock frequencies. For example, if the system clock operates at a frequency of 8MHz, the SACKS2~SACKS0 bits should not be set to 000, 001 or 111. Doing so will give A/D clock periods that are less than the

minimum A/D clock period or greater than the maximum A/D clock period which may result in inaccurate A/D conversion values. Refer to the following table for examples, where values marked with an asterisk * show where, special care must be taken, as the values may be exceed the specified A/D Clock Period range.

However, the recommended A/D clock period is from 1 μ s to 2 μ s if the input signal to be converted is the temperature sensor output voltage.

f _{sys}	A/D Clock Period (t _{ADCK})							
	SACKS [2:0]=000 (f _{sys})	SACKS [2:0]=001 (f _{sys} /2)	SACKS [2:0]=010 (f _{sys} /4)	SACKS [2:0]=011 (f _{sys} /8)	SACKS [2:0]=100 (f _{sys} /16)	SACKS [2:0]=101 (f _{sys} /32)	SACKS [2:0]=110 (f _{sys} /64)	SACKS [2:0]=111 (f _{sys} /128)
1MHz	1 μ s	2 μ s	4 μ s	8 μ s	16 μ s *	32 μ s *	64 μ s *	128 μ s *
2MHz	500ns	1 μ s	2 μ s	4 μ s	8 μ s	16 μ s *	32 μ s *	64 μ s *
4MHz	250ns *	500ns	1 μ s	2 μ s	4 μ s	8 μ s	16 μ s *	32 μ s *
8MHz	125ns *	250ns *	500ns	1 μ s	2 μ s	4 μ s	8 μ s	16 μ s *
12MHz	83ns *	167ns *	333ns *	667ns	1.33 μ s	2.67 μ s	5.33 μ s	10.67 μ s *
16MHz	62.5ns *	125ns *	250ns *	500ns	1 μ s	2 μ s	4 μ s	8 μ s

A/D Clock Period Examples @ 2.0V ≤ V_{DD} ≤ 5.5V

Controlling the power on/off function of the A/D converter circuitry is implemented using the ADCEN bit in the SADC0 register. This bit must be set high to power on the A/D converter. When the ADCEN bit is set high to power on the A/D converter internal circuitry, a certain delay as indicated in the timing diagram must be allowed before an A/D conversion is initiated. Even if no pins are selected for use as A/D inputs, if the ADCEN bit is high, then some power will still be consumed. In power conscious applications it is therefore recommended that the ADCEN is set low to reduce power consumption when the A/D converter function is not being used.

Conversion Rate and Timing Diagram

A complete A/D conversion contains two parts, data sampling and data conversion. The data sampling which is defined as t_{ADS} takes 4 A/D clock periods and the data conversion takes 12 A/D clock periods. Therefore a total of 16 A/D clock periods for an analog signal A/D conversion which is defined as t_{ADC} are necessary.

$$\text{Maximum single A/D conversion rate} = 1/(\text{A/D clock period} \times 16)$$

The accompanying diagram shows graphically the various stages involved in an external channel input signal analog to digital conversion process and its associated timing. After an A/D conversion process has been initiated by the application program, the microcontroller internal hardware will begin to carry out the conversion, during which time the program can continue with other functions. The time taken for the A/D conversion is 16 t_{ADCK} where t_{ADCK} is equal to the A/D clock period.

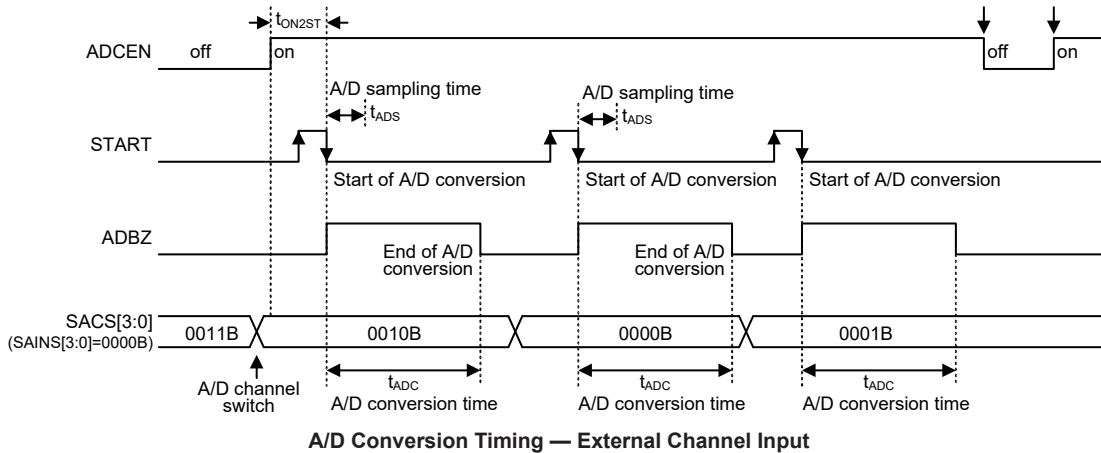

Summary of A/D Conversion Steps

The following summarises the individual steps that should be executed in order to implement an A/D conversion process.

- Step 1
 Select the required A/D conversion clock by properly programming the SACKS2~SACKS0 bits in the SADC1 register.
- Step 2
 Enable the A/D converter by setting the ADCEN bit in the SADC0 register to one.
- Step 3
 Select which signal is to be connected to the internal A/D converter by correctly configuring the SACS and SAINS bit fields
 Selecting the external channel input to be converted, go to Step 4.
 Selecting the internal analog signal to be converted, go to Step 5.
- Step 4
 If the SAINS field is 0000, 0100 or 11xx, the external channel input can be selected. The desired external channel input is selected by configuring the SACS field. When the A/D input signal comes from the external channel input, the corresponding pin should be configured as an A/D input function by selecting the relevant pin-shared function control bits. Then go to Step 6.
- Step 5
 If the SAINS field is set to 0x01, 0x10 or 0x11, the relevant internal analog signal will be selected. When the internal analog signal is selected to be converted, the external channel analog input will automatically be disconnected. Then go to Step 6.
- Step 6
 Select the A/D converter output data format by configuring the ADRFS bit.
- Step 7
 Select the A/D converter reference voltage source by configuring the SAVRS bit field.
 Select the PGA input signal and the desired PGA gain if the PGA output voltage, V_R , is selected as the A/D converter reference voltage.
- Step 8
 If A/D conversion interrupt is used, the interrupt control registers must be correctly configured to ensure the A/D interrupt function is active. The master interrupt control bit, EMI, and the A/D conversion interrupt control bit, ADE, must both be set high in advance.

- Step 9
The A/D conversion procedure can now be initialized by setting the START bit from low to high and then low again.
- Step 10
If A/D conversion is in progress, the ADBZ flag will be set high. After the A/D conversion process is complete, the ADBZ flag will go low and then the output data can be read from SADOH and SADOL registers.

Note: When checking for the end of the conversion process, if the method of polling the ADBZ bit in the SADC0 register is used, the interrupt enable step above can be omitted.

Programming Considerations

During microcontroller operations where the A/D converter is not being used, the A/D internal circuitry can be switched off to reduce power consumption, by setting bit ADCEN low in the SADC0 register. When this happens, the internal A/D converter circuits will not consume power irrespective of what analog voltage is applied to their input lines. If the A/D converter input lines are used as normal I/Os, then care must be taken as if the input voltage is not at a valid logic level, then this may lead to some increase in power consumption.

A/D Transfer Function

As the device contains a 12-bit A/D converter, its full-scale converted digitised value is equal to FFFH. Since the full-scale analog input value is equal to the actual A/D converter reference voltage, V_{REF} , this gives a single bit analog input value of reference voltage value divided by 4096.

$$1 \text{ LSB} = V_{REF} / 4096$$

The A/D Converter input voltage value can be calculated using the following equation:

$$\text{A/D input voltage} = \text{A/D output digital value} \times V_{REF} / 4096$$

The diagram shows the ideal transfer function between the analog input value and the digitised output value for the A/D converter. Except for the digitised zero value, the subsequent digitised values will change at a point 0.5 LSB below where they would change without the offset, and the last full scale digitised value will change at a point 1.5 LSB below the V_{REF} level.

Note that here the V_{REF} voltage is the actual A/D converter reference voltage determined by the SAVRS field.

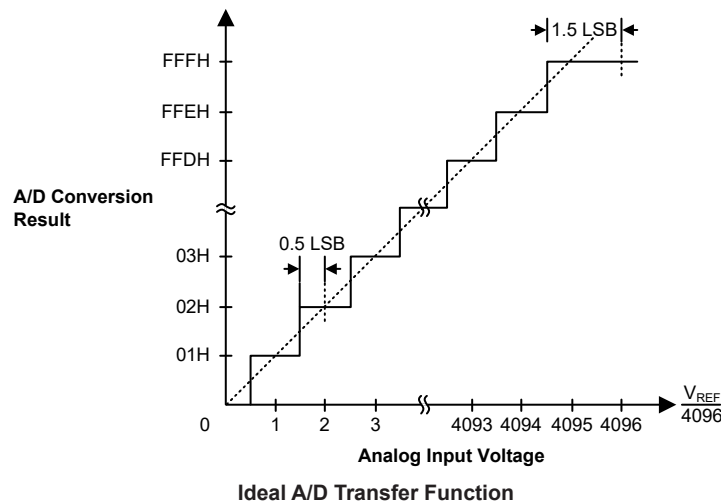

A/D Programming Examples

The following two programming examples illustrate how to setup and implement an A/D conversion. In the first example, the method of polling the ADBZ bit in the SADC0 register is used to detect when the conversion cycle is complete, whereas in the second example, the A/D interrupt is used to determine when the conversion is complete.

Example: using an ADBZ polling method to detect the end of conversion

```
clr ADE                ; disable ADC interrupt
mov a,03H              ; select fsys/8 as A/D clock and A/D input
mov SADC1,a            ; signal comes from external channel
mov a,00H              ; select AVDD as the A/D reference voltage source
mov SADC2,a
mov a,03H              ; setup PCS0 to configure pin AN0
mov PCS0,a
mov a,20H              ; enable A/D converter and select AN0 as the A/D external channel input
mov SADC0,a
:
start_conversion:
clr START              ; high pulse on start bit to initiate conversion
set START              ; reset A/D
clr START              ; start A/D
:
polling_EOC:
sz ADBZ                ; poll the SADC0 register ADBZ bit to detect end of A/D conversion
jmp polling_EOC        ; continue polling
:
mov a,SADOL             ; read low byte conversion result value
mov SADOL_buffer,a     ; save result to user defined register
mov a,SAD0H             ; read high byte conversion result value
mov SADOH_buffer,a    ; save result to user defined register
:
jmp start_conversion   ; start next A/D conversion
```

Example: using the interrupt method to detect the end of conversion

```
clr ADE                ; disable ADC interrupt
mov a,03H              ; select fsys/8 as A/D clock and A/D input
mov SADC1,a            ; signal comes from external channel
mov a,00H              ; select AVDD as the A/D reference voltage source
mov SADC2,a
mov a,03h              ; setup PCS0 to configure pin AN0
mov PCS0,a
mov a,20h              ; enable A/D converter and select AN0 as the A/D external channel input
mov SADC0,a
:
Start_conversion:
clr START              ; high pulse on START bit to initiate conversion
set START              ; reset A/D
clr START              ; start A/D
clr ADF                ; clear ADC interrupt request flag
set ADE                ; enable ADC interrupt
set EMI                ; enable global interrupt
:
:
ADC_ISR:
mov acc_stack,a       ; save ACC to user defined memory
mov a,STATUS
```

```

mov status_stack,a    ; save STATUS to user defined memory
:
mov a,SADOL           ; read low byte conversion result value
mov SADOL_buffer,a   ; save result to user defined register
mov a,SADOH           ; read high byte conversion result value
mov SADOH_buffer,a   ; save result to user defined register
:
EXIT_INT_ISR:
mov a,status_stack
mov STATUS,a         ; restore STATUS from user defined memory
mov a,acc_stack      ; restore ACC from user defined memory
reti

```

Serial Interface Module – SIM

The device contains a Serial Interface Module, which includes the four-line SPI interface, the two-line I²C interface types, to allow an easy method of communication with external peripheral hardware. Having relatively simple communication protocols, these serial interface types allow the microcontroller to interface to external SPI or I²C based hardware such as sensors, Flash or EEPROM memory, etc. The SIM interface pins are pin-shared with other I/O pins therefore the SIM interface functional pins must first be selected using the corresponding pin-shared function selection bits. As both interface types share the same pins and registers, the choice of whether the SPI or I²C type is used is made using SIM operating mode control bits, named SIM2~SIM0, in the SIMC0 register. These pull-high resistors of the SIM pin-shared I/O are selected using pull-high control registers when the SIM function is enabled and the corresponding pins are used as SIM input pins.

SPI Interface

This SPI interface function, which is part of the Serial Interface Module, should not be confused with the other independent SPI function, which is described in another section of this datasheet.

The SPI interface is often used to communicate with external peripheral devices such as sensors, Flash or EEPROM memory devices etc. Originally developed by Motorola, the four line SPI interface is a synchronous serial data interface that has a relatively simple communication protocol simplifying the programming requirements when communicating with external hardware devices.

The communication is full duplex and operates as a slave/master type, where the device can be either master or slave. Although the SPI interface specification can control multiple slave devices from a single master, but the device provides only one $\overline{\text{SCS}}$ pin. If the master needs to control multiple slave devices from a single master, the master can use I/O pin to select the slave devices.

SPI Interface Operation

The SPI interface is a full duplex synchronous serial data link. It is a four line interface with pin names SDI, SDO, SCK and $\overline{\text{SCS}}$ Pins SDI and SDO are the Serial Data Input and Serial Data Output lines, the SCK pin is the Serial Clock line and $\overline{\text{SCS}}$ is the Slave Select line. As the SPI interface pins are pin-shared with normal I/O pins and with the I²C function pins, the SPI interface pins must first be selected by setting the correct bits in the SIMC0 and SIMC2 registers. After the desired SPI configuration has been set it can be disabled or enabled using the SIMEN bit in the SIMC0 register. Communication between devices connected to the SPI interface is carried out in a slave/master mode with all data transfer initiations being implemented by the master. The Master also controls the clock signal. As the device only contains a single $\overline{\text{SCS}}$ pin only one slave device can be utilized. The $\overline{\text{SCS}}$ pin is controlled by software, set CSEN bit to 1 to enable $\overline{\text{SCS}}$ pin function, set CSEN bit to 0 the $\overline{\text{SCS}}$ pin will be floating state.

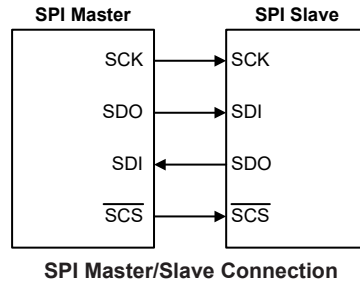

The SPI function in the device offers the following features:

- Full duplex synchronous data transfer
- Both Master and Slave modes
- LSB first or MSB first data transmission modes
- Transmission complete flag
- Rising or falling active clock edge

The status of the SPI interface pins is determined by a number of factors such as whether the device is in the master or slave mode and upon the condition of certain control bits such as CSEN and SIMEN.

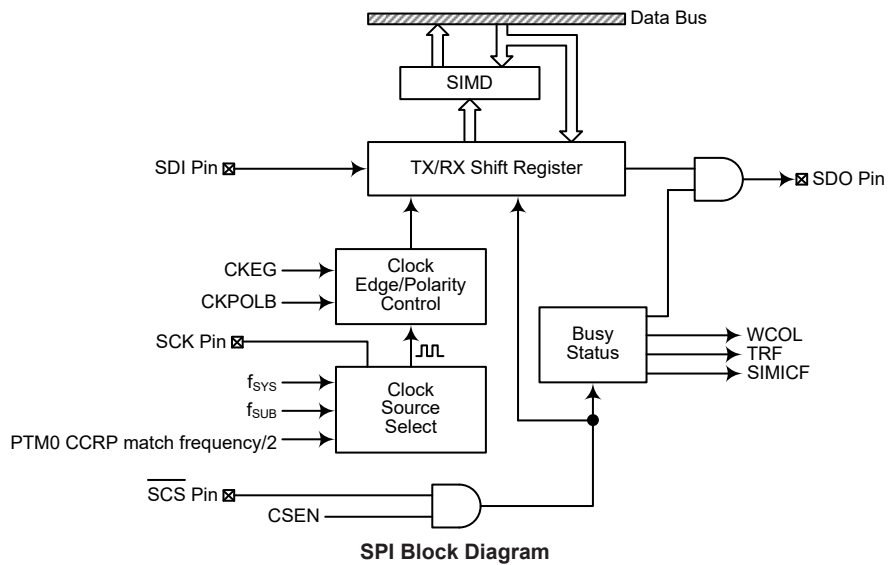

SPI Registers

There are three internal registers which control the overall operation of the SPI interface. These are the SIMD data register and two control registers, SIMC0 and SIMC2. The SIMC1 register is only used by the I²C interface.

Register Name	Bit							
	7	6	5	4	3	2	1	0
SIMC0	SIM2	SIM1	SIM0	—	SIMDEB1	SIMDEB0	SIMEN	SIMICF
SIMC2	D7	D6	CKPOLB	CKEG	MLS	CSEN	WCOL	TRF
SIMD	D7	D6	D5	D4	D3	D2	D1	D0

SPI Register List

SPI Data Register

The SIMD register is used to store the data being transmitted and received. The same register is used by both the SPI and I²C functions. Before the device writes data to the SPI bus, the actual data to be transmitted must be placed in the SIMD register. After the data is received from the SPI bus, the device can read it from the SIMD register. Any transmission or reception of data from the SPI bus must be made via the SIMD register.

• SIMD Register

Bit	7	6	5	4	3	2	1	0
Name	D7	D6	D5	D4	D3	D2	D1	D0
R/W	R/W	R/W	R/W	R/W	R/W	R/W	R/W	R/W
POR	x	x	x	x	x	x	x	x

"x": Unknown

Bit 7~0 **D7~D0**: SIM SPI/I²C data register bit 7 ~ bit 0

SPI Control Registers

There are also two control registers for the SPI interface, SIMC0 and SIMC2. The SIMC0 register is used to control the enable/disable function and to set the data transmission clock frequency. The SIMC2 register is used for other control functions such as LSB/MSB selection, write collision flag etc.

• SIMC0 Register

Bit	7	6	5	4	3	2	1	0
Name	SIM2	SIM1	SIM0	—	SIMDEB1	SIMDEB0	SIMEN	SIMICF
R/W	R/W	R/W	R/W	—	R/W	R/W	R/W	R/W
POR	1	1	1	—	0	0	0	0

Bit 7~5 **SIM2~SIM0**: SIM operating mode control
 000: SPI master mode; SPI clock is $f_{SYS}/4$
 001: SPI master mode; SPI clock is $f_{SYS}/16$
 010: SPI master mode; SPI clock is $f_{SYS}/64$
 011: SPI master mode; SPI clock is f_{SUB}
 100: SPI master mode; SPI clock is PTM0 CCRP match frequency/2
 101: SPI slave mode
 110: I²C slave mode
 111: Unused mode

These bits setup the overall operating mode of the SIM function. As well as selecting if the I²C or SPI function, they are used to control the SPI Master/Slave selection and the SPI Master clock frequency. The SPI clock is a function of the system clock but can also be chosen to be sourced from PTM0 and f_{SUB} . If the SPI Slave mode is selected then the clock will be supplied by an external Master device.

Bit 4 Unimplemented, read as "0"

Bit 3~2 **SIMDEB1~SIMDEB0**: I²C Debounce Time Selection

These bits are only available when the SIM is configured to operate in the I²C mode. Refer to the I²C register section

- Bit 1 **SIMEN**: SIM enable control
 0: Disable
 1: Enable
- The bit is the overall on/off control for the SIM interface. When the SIMEN bit is cleared to zero to disable the SIM interface, the SDI, SDO, SCK and \overline{SCS} , or SDA and SCL lines will lose their SPI or I²C function and the SIM operating current will be reduced to a minimum value. When the bit is high the SIM interface is enabled. If the SIM is configured to operate as an SPI interface via the SIM2~SIM0 bits, the contents of the SPI control registers will remain at the previous settings when the SIMEN bit changes from low to high and should therefore be first initialised by the application program. If the SIM is configured to operate as an I²C interface via the SIM2~SIM0 bits and the SIMEN bit changes from low to high, the contents of the I²C control bits such as HTX and TXAK will remain at the previous settings and should therefore be first initialised by the application program while the relevant I²C flags such as HCF, HAAS, HBB, SRW and RXAK will be set to their default states.
- Bit 0 **SIMICF**: SIM SPI incomplete flag
 0: SIM SPI incomplete condition is not occurred
 1: SIM SPI incomplete condition is occurred
- This bit is only available when the SIM is configured to operate in an SPI slave mode. If the SPI operates in the slave mode with the SIMEN and CSEN bits both being set to 1 but the \overline{SCS} line is pulled high by the external master device before the SPI data transfer is completely finished, the SIMICF bit will be set to 1 together with the TRF bit. When this condition occurs, the corresponding interrupt will occur if the interrupt function is enabled. However, the TRF bit will not be set to 1 if the SIMICF bit is set to 1 by software application program.

• **SIMC2 Register**

Bit	7	6	5	4	3	2	1	0
Name	D7	D6	CKPOLB	CKEG	MLS	CSEN	WCOL	TRF
R/W	R/W	R/W	R/W	R/W	R/W	R/W	R/W	R/W
POR	0	0	0	0	0	0	0	0

- Bit 7~6 **D7~D6**: Undefined bits
 These bits can be read or written by the application program.
- Bit 5 **CKPOLB**: SPI clock line base condition selection
 0: The SCK line will be high when the clock is inactive
 1: The SCK line will be low when the clock is inactive
- The CKPOLB bit determines the base condition of the clock line, if the bit is high, then the SCK line will be low when the clock is inactive. When the CKPOLB bit is low, then the SCK line will be high when the clock is inactive.
- Bit 4 **CKEG**: SPI SCK clock active edge type selection
 CKPOLB=0
 0: SCK is high base level and data capture at SCK rising edge
 1: SCK is high base level and data capture at SCK falling edge
 CKPOLB=1
 0: SCK is low base level and data capture at SCK falling edge
 1: SCK is low base level and data capture at SCK rising edge
- The CKEG and CKPOLB bits are used to setup the way that the clock signal outputs and inputs data on the SPI bus. These two bits must be configured before data transfer is executed otherwise an erroneous clock edge may be generated. The CKPOLB bit determines the base condition of the clock line, if the bit is high, then the SCK line will be low when the clock is inactive. When the CKPOLB bit is low, then the SCK line will be high when the clock is inactive. The CKEG bit determines active clock edge type which depends upon the condition of CKPOLB bit.

- Bit 3 **MLS:** SPI data shift order
 0: LSB first
 1: MSB first
 This is the data shift select bit and is used to select how the data is transferred, either MSB or LSB first. Setting the bit high will select MSB first and low for LSB first.
- Bit 2 **CSEN:** SPI $\overline{\text{SCS}}$ pin control
 0: Disable
 1: Enable
 The CSEN bit is used as an enable/disable for the $\overline{\text{SCS}}$ pin. If this bit is low, then the $\overline{\text{SCS}}$ pin will be disabled and placed into a floating condition. If the bit is high the $\overline{\text{SCS}}$ pin will be enabled and used as a select pin.
- Bit 1 **WCOL:** SPI write collision flag
 0: No collision
 1: Collision
 The WCOL flag is used to detect if a data collision has occurred. If this bit is high it means that data has been attempted to be written to the SIMD register during a data transfer operation. This writing operation will be ignored if data is being transferred. The bit can be cleared by the application program.
- Bit 0 **TRF:** SPI transmit/receive complete flag
 0: SPI data is being transferred
 1: SPI data transmission is completed
 The TRF bit is the Transmit/Receive Complete flag and is set “1” automatically when an SPI data transmission is completed, but must set to “0” by the application program. It can be used to generate an interrupt.

SPI Communication

After the SPI interface is enabled by setting the SIMEN bit high, then in the Master Mode, when data is written to the SIMD register, transmission/reception will begin simultaneously. When the data transfer is completed, the TRF flag will be set high automatically, but must be cleared using the application program. In the Slave Mode, when the clock signal from the master has been received, any data in the SIMD register will be transmitted and any data on the SDI pin will be shifted into the SIMD register. The master should output an $\overline{\text{SCS}}$ signal to enable the slave devices before a clock signal is provided. The slave data to be transferred should be well prepared at the appropriate moment relative to the SCK signal depending upon the configurations of the CKPOLB bit and CKEG bit. The accompanying timing diagram shows the relationship between the slave data and SCK signal for various configurations of the CKPOLB and CKEG bits.

The SPI Master mode will continue to function if the SPI clock is running.

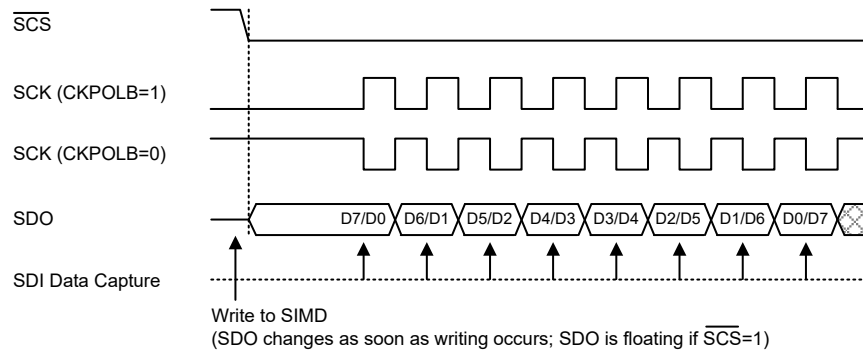
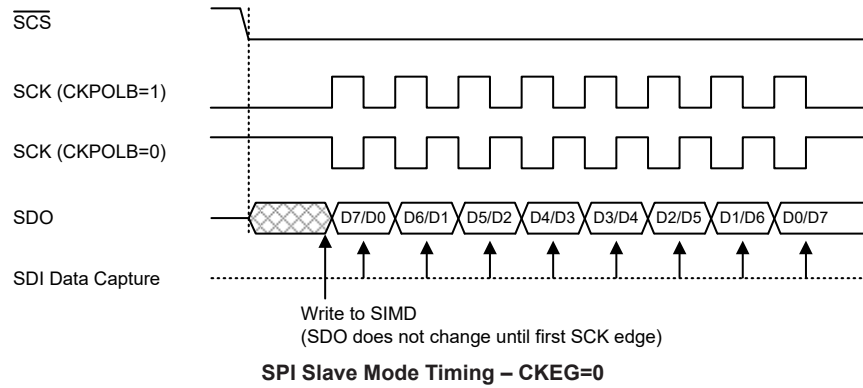
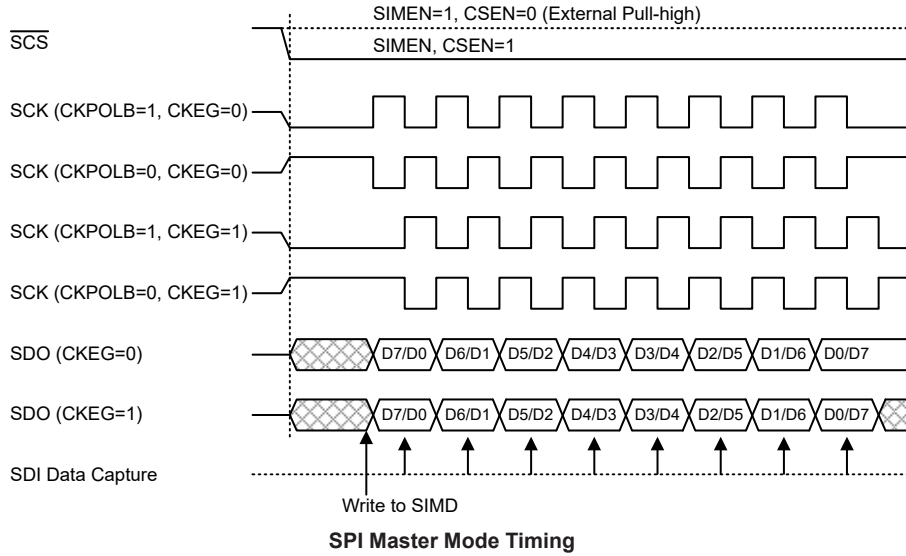

Note: For SPI slave mode, if SIMEN=1 and CSEN=0, SPI is always enabled and ignores the SCS level.

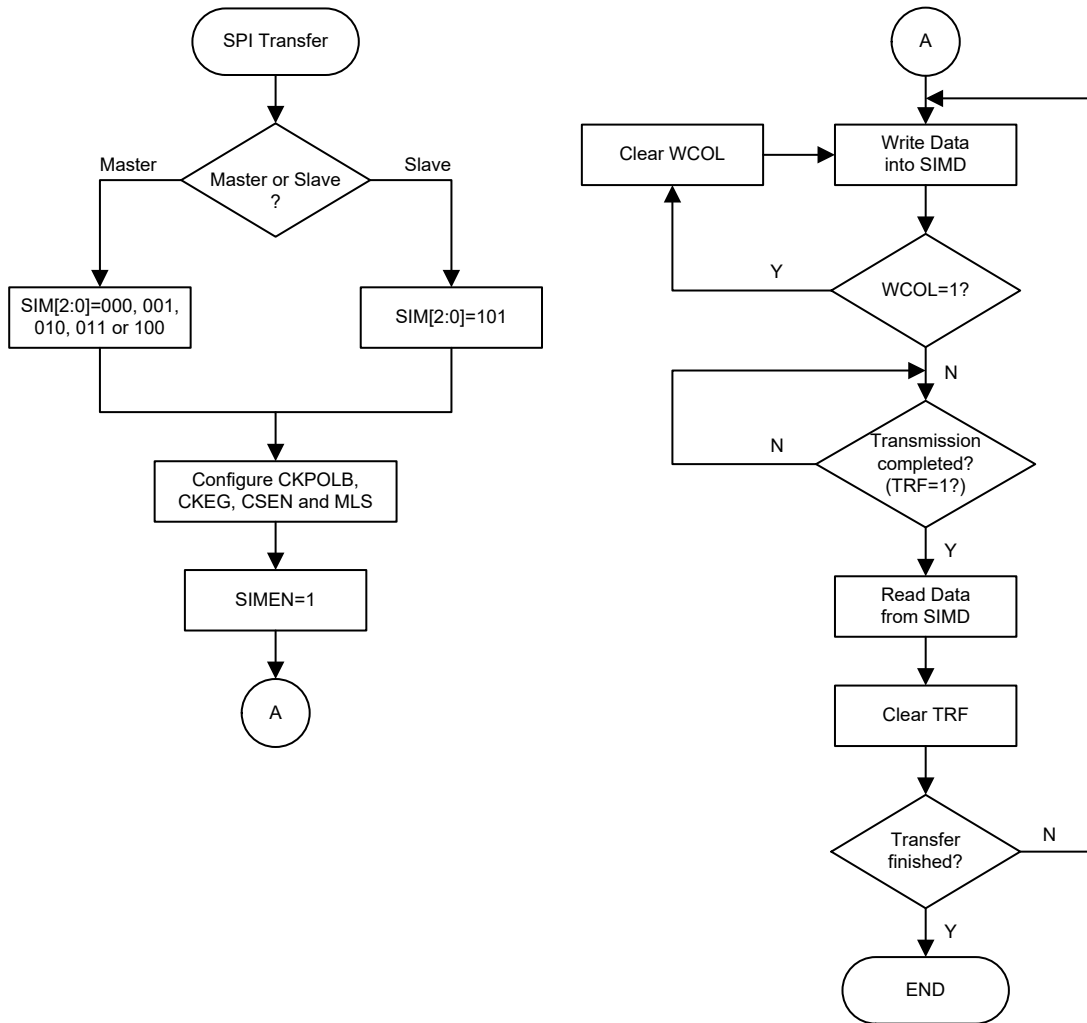

SPI Transfer Control Flowchart

SPI Bus Enable/Disable

To enable the SPI bus, set CSEN=1 and \overline{SCS} =0, then wait for data to be written into the SIMD (TXRX buffer) register. For the Master Mode, after data has been written to the SIMD (TXRX buffer) register, then transmission or reception will start automatically. When all the data has been transferred, the TRF bit should be set. For the Slave Mode, when clock pulses are received on SCK, data in the TXRX buffer will be shifted out or data on SDI will be shifted in.

When the SPI bus is disabled, SCK, SDI, SDO and \overline{SCS} can become I/O pins or other pin-shared functions using the corresponding control bits.

SPI Operation Steps

All communication is carried out using the 4-line interface for either Master or Slave Mode.

The CSEN bit in the SIMC2 register controls the overall function of the SPI interface. Setting this bit high will enable the SPI interface by allowing the \overline{SCS} line to be active, which can then be used to control the SPI interface. If the CSEN bit is low, the SPI interface will be disabled and the \overline{SCS} line will be in a floating condition and can therefore not be used for control of the SPI interface. If the CSEN bit and the SIMEN bit in the SIMC0 are set high, this will place the SDI line in a floating condition and the SDO line high. If in Master Mode the SCK line will be either high or low depending upon the clock polarity selection bit CKPOLB in the SIMC2 register. If in Slave Mode the SCK line will be in a floating condition. If the SIMEN bit is low, then the bus will be disabled and \overline{SCS} , SDI, SDO and SCK will all become I/O pins or the other functions using the corresponding control bits. In the Master Mode the Master will always generate the clock signal. The clock and data transmission will be initiated after data has been written into the SIMD register. In the Slave Mode, the clock signal will be received from an external master device for both data transmission and reception. The following sequences show the order to be followed for data transfer in both Master and Slave Mode.

Master Mode

- Step 1
Select the SPI Master mode and clock source using the SIM2~SIM0 bits in the SIMC0 control register.
- Step 2
Setup the CSEN bit and setup the MLS bit to choose if the data is MSB or LSB first, this setting must be the same with the Slave devices.
- Step 3
Setup the SIMEN bit in the SIMC0 control register to enable the SPI interface.
- Step 4
For write operations: write the data to the SIMD register, which will actually place the data into the TXRX buffer. Then use the SCK and SDO lines to output the data. After this, go to step 5.
For read operations: the data transferred in on the SDI line will be stored in the TXRX buffer until all the data has been received at which point it will be latched into the SIMD register.
- Step 5
Check the WCOL bit if set high then a collision error has occurred so return to step 4. If equal to zero then go to the following step.
- Step 6
Check the TRF bit or wait for a SPI serial bus interrupt.
- Step 7
Read data from the SIMD register.

- Step 8
Clear TRF.
- Step 9
Go to step 4.

Slave Mode

- Step 1
Select the SPI Slave mode using the SIM2~SIM0 bits in the SIMC0 control register
- Step 2
Setup the CSEN bit and setup the MLS bit to choose if the data is MSB or LSB first, this setting must be the same with the Master devices.
- Step 3
Setup the SIMEN bit in the SIMC0 control register to enable the SPI interface.
- Step 4
For write operations: write the data to the SIMD register, which will actually place the data into the TXRX buffer. Then wait for the master clock SCK and $\overline{\text{SCS}}$ signal. After this, go to step 5.
For read operations: the data transferred in on the SDI line will be stored in the TXRX buffer until all the data has been received at which point it will be latched into the SIMD register.
- Step 5
Check the WCOL bit if set high then a collision error has occurred so return to step 4. If equal to zero then go to the following step.
- Step 6
Check the TRF bit or wait for a SPI serial bus interrupt.
- Step 7
Read data from the SIMD register.
- Step 8
Clear TRF.
- Step 9
Go to step 4.

Error Detection

The WCOL bit in the SIMC2 register is provided to indicate errors during data transfer. The bit is set by the SPI serial Interface but must be cleared by the application program. This bit indicates that a data collision has occurred which happens if a write to the SIMD register takes place during a data transfer operation and will prevent the write operation from continuing.

I²C Interface

The I²C interface is used to communicate with external peripheral devices such as sensors, EEPROM memory etc. Originally developed by Philips, it is a two line low speed serial interface for synchronous serial data transfer. The advantage of only two lines for communication, relatively simple communication protocol and the ability to accommodate multiple devices on the same bus has made it an extremely popular interface type for many applications.

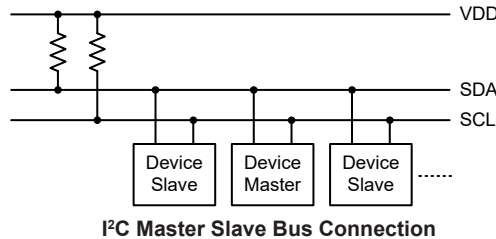

I²C Interface Operation

The I²C serial interface is a two line interface, a serial data line, SDA, and serial clock line, SCL. As many devices may be connected together on the same bus, their outputs are both open drain types. For this reason it is necessary that external pull-high resistors are connected to these outputs. Note that no chip select line exists, as each device on the I²C bus is identified by a unique address which will be transmitted and received on the I²C bus.

When two devices communicate with each other on the bidirectional I²C bus, one is known as the master device and one as the slave device. Both master and slave can transmit and receive data, however, it is the master device that has overall control of the bus. For the device, which only operates in slave mode, there are two methods of transferring data on the I²C bus, the slave transmit mode and the slave receive mode. The pull-high control function pin-shared with SCL/SDA pin is still applicable even if I²C device is activated and the related internal pull-high function could be controlled by its corresponding pull-high control register.

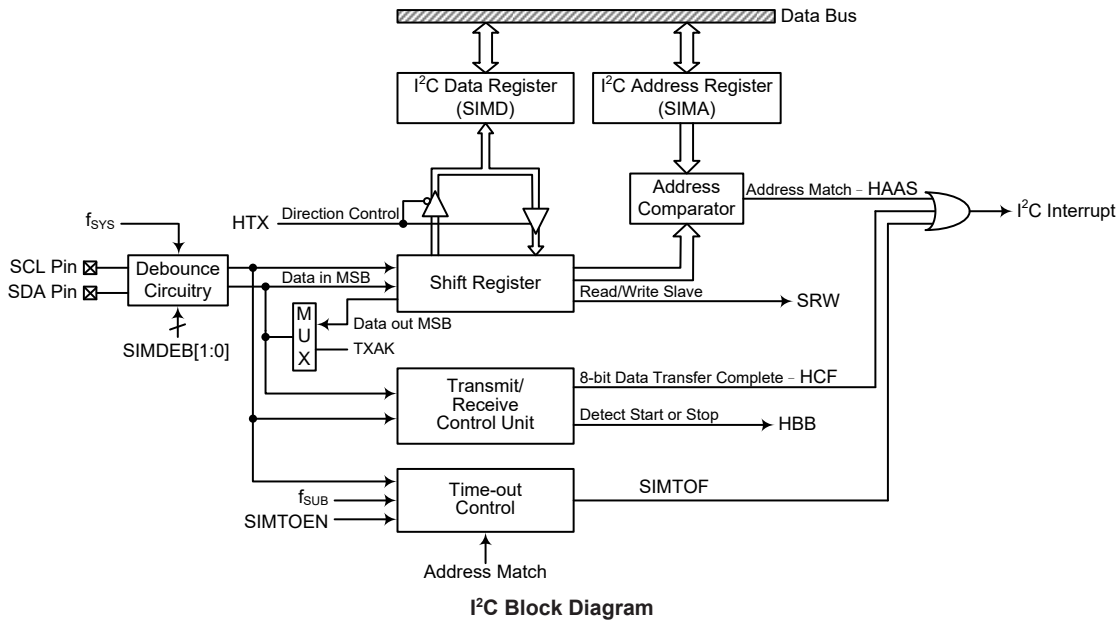

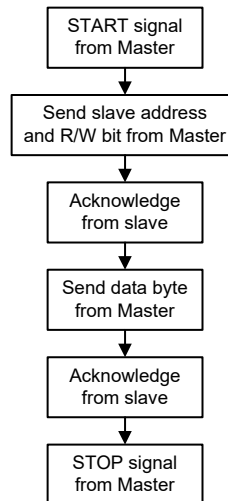

I²C Interface Operation

The SIMDEB1 and SIMDEB0 bits determine the debounce time of the I²C interface. This uses the internal clock to in effect add a debounce time to the external clock to reduce the possibility of glitches on the clock line causing erroneous operation. The debounce time, if selected, can be chosen to be either 2 or 4 system clocks. To achieve the required I²C data transfer speed, there exists a relationship between the system clock, f_{SYS} , and the I²C debounce time. For either the I²C Standard or Fast mode operation, users must take care of the selected system clock frequency and the configured debounce time to match the criterion shown in the following table.

I ² C Debounce Time Selection	I ² C Standard Mode (100kHz)	I ² C Fast Mode (400kHz)
No Debounce	$f_{SYS} > 2\text{MHz}$	$f_{SYS} > 4\text{MHz}$
2 system clock debounce	$f_{SYS} > 4\text{MHz}$	$f_{SYS} > 8\text{MHz}$
4 system clock debounce	$f_{SYS} > 4\text{MHz}$	$f_{SYS} > 8\text{MHz}$

I²C Minimum f_{SYS} Frequency Requirements

I²C Registers

There are three control registers associated with the I²C bus, SIMC0, SIMC1 and SIMTOC, one address register SIMA and one data register, SIMD.

Register Name	Bit							
	7	6	5	4	3	2	1	0
SIMC0	SIM2	SIM1	SIM0	—	SIMDEB1	SIMDEB0	SIMEN	SIMICF
SIMC1	HCF	HAAS	HBB	HTX	TXAK	SRW	IAMWU	RXAK
SIMD	D7	D6	D5	D4	D3	D2	D1	D0
SIMA	SIMA6	SIMA5	SIMA4	SIMA3	SIMA2	SIMA1	SIMA0	D0
SIMTOC	SIMTOEN	SIMTOF	SIMTOS5	SIMTOS4	SIMTOS3	SIMTOS2	SIMTOS1	SIMTOS0

I²C Register List

I²C Data Register

The SIMD register is used to store the data being transmitted and received. The same register is used by both the SPI and I²C functions. Before the device writes data to the I²C bus, the actual data to be transmitted must be placed in the SIMD register. After the data is received from the I²C bus, the device can read it from the SIMD register. Any transmission or reception of data from the I²C bus must be made via the SIMD register.

• **SIMD Register**

Bit	7	6	5	4	3	2	1	0
Name	D7	D6	D5	D4	D3	D2	D1	D0
R/W	R/W	R/W	R/W	R/W	R/W	R/W	R/W	R/W
POR	x	x	x	x	x	x	x	x

“x”: Unknown

Bit 7~0 **D7~D0**: SIM SPI/I²C data register bit 7 ~ bit 0

I²C Address Register

The SIMA register is also used by the SPI interface but has the name SIMC2. The SIMA register is the location where the 7-bit slave address of the slave device is stored. Bits 7~1 of the SIMA register define the device slave address. Bit 0 is not defined. When a master device, which is connected to the I²C bus, sends out an address, which matches the slave address in the SIMA register, the slave device will be selected. Note that the SIMA register is the same register address as SIMC2 which is used by the SPI interface.

• **SIMA Register**

Bit	7	6	5	4	3	2	1	0
Name	SIMA6	SIMA5	SIMA4	SIMA3	SIMA2	SIMA1	SIMA0	D0
R/W	R/W	R/W	R/W	R/W	R/W	R/W	R/W	R/W
POR	0	0	0	0	0	0	0	0

Bit 7~1 **SIMA6~SIMA0**: I²C slave address
 SIMA6~SIMA0 is the I²C slave address bit 6 ~ bit 0.

Bit 0 **D0**: Reserved bit, can be read or written

I²C Control Registers

There are three control registers for the I²C interface, SIMC0, SIMC1 and SIMTOC. The SIMC0 register is used to control the enable/disable function and to set the data transmission clock frequency. The SIMC1 register contains the relevant flags which are used to indicate the I²C communication status. Another register, SIMTOC, is used to control the I²C time-out function and is described in the corresponding section.

• **SIMC0 Register**

Bit	7	6	5	4	3	2	1	0
Name	SIM2	SIM1	SIM0	—	SIMDEB1	SIMDEB0	SIMEN	SIMICF
R/W	R/W	R/W	R/W	—	R/W	R/W	R/W	R/W
POR	1	1	1	—	0	0	0	0

Bit 7~5 **SIM2~SIM0**: SIM operating mode control
 000: SPI master mode; SPI clock is $f_{SYS}/4$
 001: SPI master mode; SPI clock is $f_{SYS}/16$
 010: SPI master mode; SPI clock is $f_{SYS}/64$
 011: SPI master mode; SPI clock is f_{SUB}
 100: SPI master mode; SPI clock is PTM0 CCRP match frequency/2
 101: SPI slave mode
 110: I²C slave mode
 111: Unused mode

These bits setup the SPI or I²C operating mode of the SIM function. As well as selecting if the I²C or SPI function, they are used to control the SPI Master/Slave selection and the SPI Master clock frequency. The SPI clock is a function of the system clock but can also be chosen to be sourced from PTM0 and f_{SUB} . If the SPI Slave Mode is selected then the clock will be supplied by an external Master device.

Bit 4 Unimplemented, read as “0”

- Bit 3~2 **SIMDEB1~SIMDEB0**: I²C debounce time selection
 00: No debounce
 01: 2 system clock debounce
 1x: 4 system clock debounce
 These bits are used to select the I²C debounce time when the SIM is configured as the I²C interface function by setting the SIM2~SIM0 bits to “110”.
- Bit 1 **SIMEN**: SIM enable control
 0: Disable
 1: Enable
 The bit is the overall on/off control for the SIM interface. When the **SIMEN** bit is cleared to zero to disable the SIM interface, the **SDL**, **SDO**, **SCK** and **SCS**, or **SDA** and **SCL** lines will lose their SPI or I²C function and the SIM operating current will be reduced to a minimum value. When the bit is high the SIM interface is enabled. If the SIM is configured to operate as an SPI interface via the SIM2~SIM0 bits, the contents of the SPI control registers will remain at the previous settings when the **SIMEN** bit changes from low to high and should therefore be first initialised by the application program. If the SIM is configured to operate as an I²C interface via the SIM2~SIM0 bits and the **SIMEN** bit changes from low to high, the contents of the I²C control bits such as **HTX** and **TXAK** will remain at the previous settings and should therefore be first initialised by the application program while the relevant I²C flags such as **HCF**, **HAAS**, **HBB**, **SRW** and **RXAK** will be set to their default states.
- Bit 0 **SIMICF**: SIM SPI incomplete flag
 This bit is only available when the SIM is configured to operate in an SPI slave mode. Refer to the SPI register section.

• **SIMC1 Register**

Bit	7	6	5	4	3	2	1	0
Name	HCF	HAAS	HBB	HTX	TXAK	SRW	IAMWU	RXAK
R/W	R	R	R	R/W	R/W	R	R/W	R
POR	1	0	0	0	0	0	0	1

- Bit 7 **HCF**: I²C bus data transfer completion flag
 0: Data is being transferred
 1: Completion of an 8-bit data transfer
 The **HCF** flag is the data transfer flag. This flag will be zero when data is being transferred. Upon completion of an 8-bit data transfer the flag will go high and an interrupt will be generated.
- Bit 6 **HAAS**: I²C bus address match flag
 0: Not address match
 1: Address match
 This flag is used to determine if the slave device address is the same as the master transmit address. If the addresses match then this bit will be high, if there is no match then the flag will be low.
- Bit 5 **HBB**: I²C bus busy flag
 0: I²C Bus is not busy
 1: I²C Bus is busy
 The **HBB** flag is the I²C busy flag. This flag will be “1” when the I²C bus is busy which will occur when a **START** signal is detected. The flag will be set to “0” when the bus is free which will occur when a **STOP** signal is detected.
- Bit 4 **HTX**: I²C slave device is transmitter or receiver selection
 0: Slave device is the receiver
 1: Slave device is the transmitter
- Bit 3 **TXAK**: I²C bus transmit acknowledge flag
 0: Slave send acknowledge flag
 1: Slave do not send acknowledge flag

- The TXAK bit is the transmit acknowledge flag. After the slave device receipt of 8 bits of data, this bit will be transmitted to the bus on the 9th clock from the slave device. The slave device must always set TXAK bit to “0” before further data is received.
- Bit 2 **SRW**: I²C slave read/write flag
 0: Slave device should be in receive mode
 1: Slave device should be in transmit mode
- The SRW flag is the I²C Slave Read/Write flag. This flag determines whether the master device wishes to transmit or receive data from the I²C bus. When the transmitted address and slave address is match, that is when the HAAS flag is set high, the slave device will check the SRW flag to determine whether it should be in transmit mode or receive mode. If the SRW flag is high, the master is requesting to read data from the bus, so the slave device should be in transmit mode. When the SRW flag is zero, the master will write data to the bus, therefore the slave device should be in receive mode to read this data.
- Bit 1 **IAMWU**: I²C address match wake-up control
 0: Disable
 1: Enable
- This bit should be set to 1 to enable the I²C address match wake up from the SLEEP or IDLE Mode. If the IAMWU bit has been set before entering either the SLEEP or IDLE mode to enable the I²C address match wake up, then this bit must be cleared by the application program after wake-up to ensure correction device operation.
- Bit 0 **RXAK**: I²C bus receive acknowledge flag
 0: Slave receive acknowledge flag
 1: Slave does not receive acknowledge flag
- The RXAK flag is the receiver acknowledge flag. When the RXAK flag is “0”, it means that a acknowledge signal has been received at the 9th clock, after 8 bits of data have been transmitted. When the slave device in the transmit mode, the slave device checks the RXAK flag to determine if the master receiver wishes to receive the next byte. The slave transmitter will therefore continue sending out data until the RXAK flag is “1”. When this occurs, the slave transmitter will release the SDA line to allow the master to send a STOP signal to release the I²C Bus.

I²C Bus Communication

Communication on the I²C bus requires four separate steps, a START signal, a slave device address transmission, a data transmission and finally a STOP signal. When a START signal is placed on the I²C bus, all devices on the bus will receive this signal and be notified of the imminent arrival of data on the bus. The first seven bits of the data will be the slave address with the first bit being the MSB. If the address of the slave device matches that of the transmitted address, the HAAS bit in the SIMC1 register will be set and a I²C interrupt will be generated. After entering the interrupt service routine, the slave device must first check the condition of the HAAS and SIMTOF bits to determine whether the interrupt source originates from an address match or from the completion of an 8-bit data transfer completion or from the I²C bus time-out occurrence. During a data transfer, note that after the 7-bit slave address has been transmitted, the following bit, which is the 8th bit, is the read/write bit whose value will be placed in the SRW bit. This bit will be checked by the slave device to determine whether to go into transmit or receive mode. Before any transfer of data to or from the I²C bus, the microcontroller must initialise the bus, the following are steps to achieve this:

- Step 1
Set the SIM2~SIM0 and SIMEN bits in the SIMC0 register to “110” and “1” respectively to enable the I²C bus.
- Step 2
Write the slave address of the device to the I²C bus address register SIMA.
- Step 3
Set the SIM interrupt and the corresponding Multi-function interrupt enable bit of the interrupt control register to enable the SIM interrupt and Multi-function interrupt.

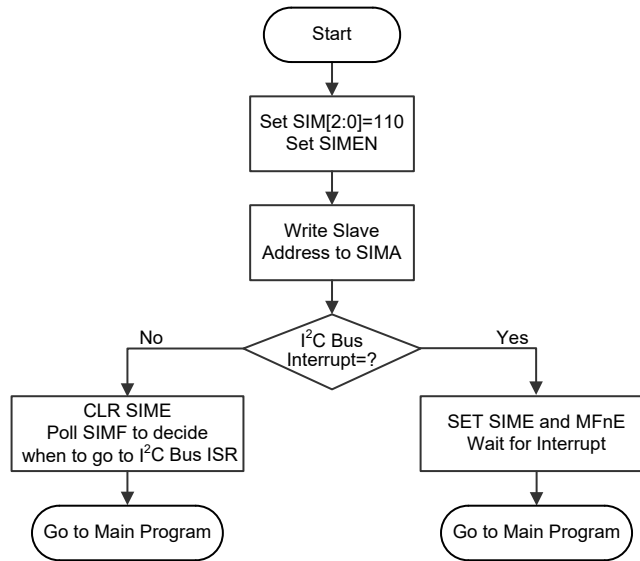

I²C Bus Initialisation Flow Chart

I²C Bus Start Signal

The START signal can only be generated by the master device connected to the I²C bus and not by the slave device. This START signal will be detected by all devices connected to the I²C bus. When detected, this indicates that the I²C bus is busy and therefore the HBB bit will be set. A START condition occurs when a high to low transition on the SDA line takes place when the SCL line remains high.

I²C Slave Address

The transmission of a START signal by the master will be detected by all devices on the I²C bus. To determine which slave device the master wishes to communicate with, the address of the slave device will be sent out immediately following the START signal. All slave devices, after receiving this 7-bit address data, will compare it with their own 7-bit slave address. If the address sent out by the master matches the internal address of the microcontroller slave device, then an internal I²C bus interrupt signal will be generated. The next bit following the address, which is the 8th bit, defines the read/write status and will be saved to the SRW bit of the SIMC1 register. The slave device will then transmit an acknowledge bit, which is a low level, as the 9th bit. The slave device will also set the status flag HAAS when the addresses match.

As an I²C bus interrupt can come from three sources, when the program enters the interrupt subroutine, the HAAS and SIMTOF bits should be examined to see whether the interrupt source has come from a matching slave address or from the completion of a data byte transfer or from the I²C bus time-out occurrence. When a slave address is matched, the device must be placed in either the transmit mode and then write data to the SIMD register, or in the receive mode where it must implement a dummy read from the SIMD register to release the SCL line.

I²C Bus Read/Write Signal

The SRW bit in the SIMC1 register defines whether the master device wishes to read data from the I²C bus or write data to the I²C bus. The slave device should examine this bit to determine if it is to be a transmitter or a receiver. If the SRW flag is “1” then this indicates that the master device wishes to read data from the I²C bus, therefore the slave device must be setup to send data to the I²C bus as a transmitter. If the SRW flag is “0” then this indicates that the master wishes to send data to the I²C bus, therefore the slave device must be setup to read data from the I²C bus as a receiver.

I²C Bus Slave Address Acknowledge Signal

After the master has transmitted a calling address, any slave device on the I²C bus, whose own internal address matches the calling address, must generate an acknowledge signal. The acknowledge signal will inform the master that a slave device has accepted its calling address. If no acknowledge signal is received by the master then a STOP signal must be transmitted by the master to end the communication. When the HAAS flag is high, the addresses have matched and the slave device must check the SRW flag to determine if it is to be a transmitter or a receiver. If the SRW flag is high, the slave device should be setup to be a transmitter so the HTX bit in the SIMC1 register should be set to “1”. If the SRW flag is low, then the microcontroller slave device should be setup as a receiver and the HTX bit in the SIMC1 register should be set to “0”.

I²C Bus Data and Acknowledge Signal

The transmitted data is 8-bit wide and is transmitted after the slave device has acknowledged receipt of its slave address. The order of serial bit transmission is the MSB first and the LSB last. After receipt of 8 bits of data, the receiver must transmit an acknowledge signal, level “0”, before it can receive the next data byte. If the slave transmitter does not receive an acknowledge bit signal from the master receiver, then the slave transmitter will release the SDA line to allow the master to send a STOP signal to release the I²C Bus. The corresponding data will be stored in the SIMD register. If setup as a transmitter, the slave device must first write the data to be transmitted into the SIMD register. If setup as a receiver, the slave device must read the transmitted data from the SIMD register.

When the slave receiver receives the data byte, it must generate an acknowledge bit, known as TXAK, on the 9th clock. The slave device, which is setup as a transmitter will check the RXAK bit in the SIMC1 register to determine if it is to send another data byte, if not then it will release the SDA line and await the receipt of a STOP signal from the master.

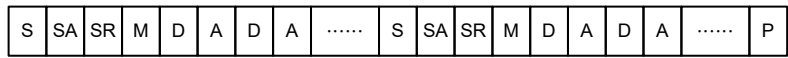
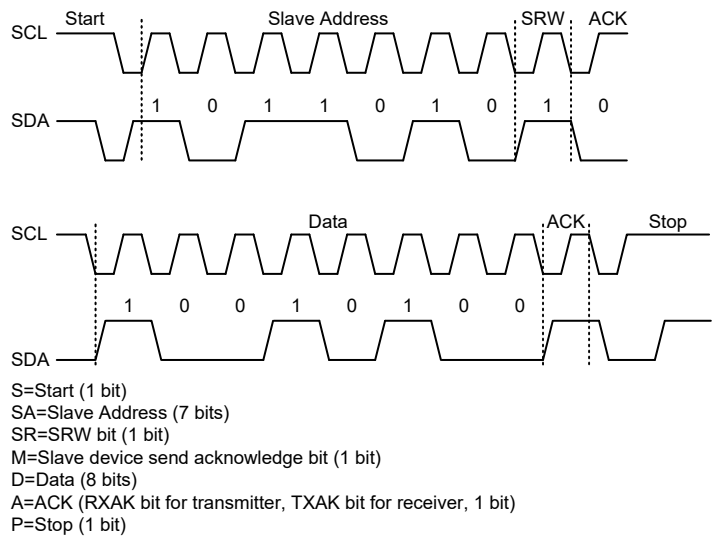

I²C Communication Timing Diagram

Note: When a slave address is matched, the device must be placed in either the transmit mode and then write data to the SIMD register, or in the receive mode where it must implement a dummy read from the SIMD register to release the SCL line.

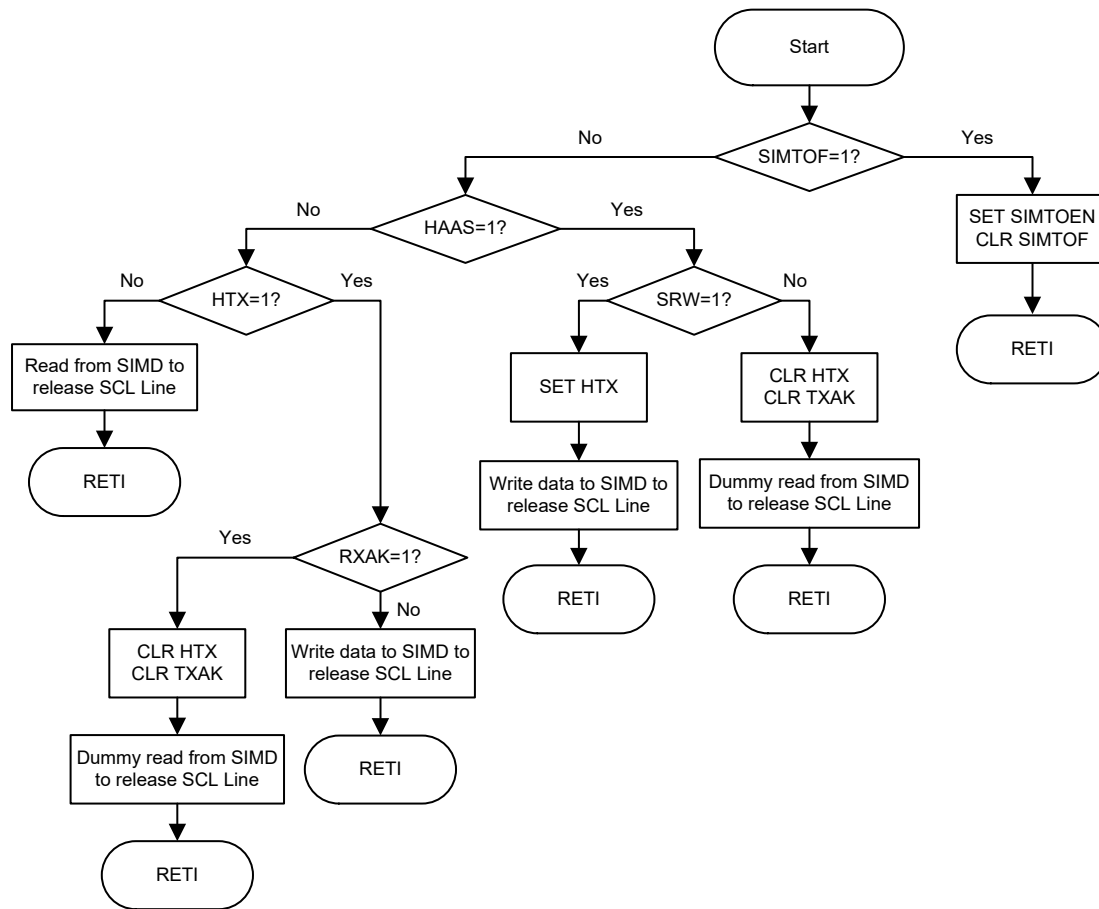

I²C Bus ISR Flow Chart

I²C Time-out Control

In order to reduce the problem of I²C lockup due to reception of erroneous clock sources, a time-out function is provided. If the clock source to the I²C is not received for a while, then the I²C circuitry and registers will be reset after a certain time-out period. The time-out counter starts counting on an I²C bus “START” & “address match” condition, and is cleared by an SCL falling edge. Before the next SCL falling edge arrives, if the time elapsed is greater than the time-out setup by the SIMTOC register, then a time-out condition will occur. The time-out function will stop when an I²C “STOP” condition occurs.

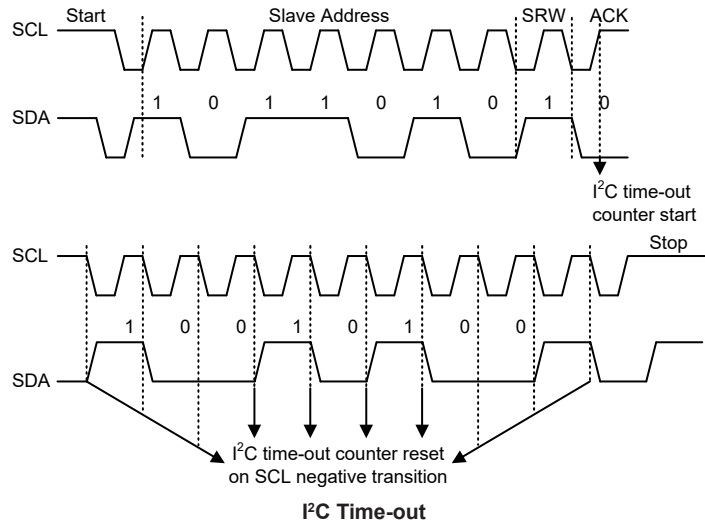

When an I²C time-out counter overflow occurs, the counter will stop and the SIMTOEN bit will be cleared to zero and the SIMTOF bit will be set high to indicate that a time-out condition has occurred. The time-out condition will also generate an interrupt which uses the I²C interrupt vector. When an I²C time-out occurs, the I²C internal circuitry will be reset and the registers will be reset into the following condition:

Registers	After I ² C Time-out
SIMD, SIMA, SIMC0	No change
SIMC1	Reset to POR condition

I²C Registers after Time-out

The SIMTOF flag can be cleared by the application program. There are 64 time-out periods which can be selected using SIMTOS bit field in the SIMTOC register. The time-out time is given by the formula: $((1\sim64)\times32)/f_{SUB}$. This gives a time-out period which ranges from about 1ms to 64ms.

• **SIMTOC Register**

Bit	7	6	5	4	3	2	1	0
Name	SIMTOEN	SIMTOF	SIMTOS5	SIMTOS4	SIMTOS3	SIMTOS2	SIMTOS1	SIMTOS0
R/W	R/W	R/W	R/W	R/W	R/W	R/W	R/W	R/W
POR	0	0	0	0	0	0	0	0

Bit 7 **SIMTOEN**: SIM I²C time-out control
 0: Disable
 1: Enable

Bit 6 **SIMTOF**: SIM I²C time-out flag
 0: No time-out occurred
 1: Time-out occurred

Bit 5~0 **SIMTOS5~SIMTOS0**: SIM I²C time-out period selection
 I²C time-out clock source is $f_{SUB}/32$.
 I²C time-out time is equal to $(SIMTOS[5:0]+1)\times(32/f_{SUB})$.

UART Interfaces

The device contains two integrated full-duplex asynchronous serial communications UART interfaces that enable communication with external devices that contain a serial interfaces. Each UART function has many features and can transmit and receive data serially by transferring a frame of data with eight or nine data bits per transmission as well as being able to detect errors when the data is overwritten or incorrectly framed. Each UART function possesses its own internal interrupt which can be used to indicate when a reception occurs or when a transmission terminates.

Each integrated UART function contains the following features:

- Full-duplex, asynchronous communication
- 8 or 9 bits character length
- Even, odd, mark, space or no parity options
- One or two stop bits
- Baud rate generator with 16-bit prescaler
- Parity, framing, noise and overrun error detection
- Support for interrupt on address detect (last character bit=1)
- Separately enabled transmitter and receiver
- 4-byte Deep FIFO Receive Data Buffer
- 1-byte Deep FIFO Transmit Data Buffer
- RXn pin wake-up function
- Transmit and receive interrupts
- Interrupts can be triggered by the following conditions:
 - ♦ Transmitter Empty
 - ♦ Transmitter Idle
 - ♦ Receiver Full
 - ♦ Receiver Overrun
 - ♦ Address Mode Detect

UART External Pins

To communicate with an external serial interface, the internal UARTn has two external pins known as TXn and RXn. The TXn and RXn pins are the UARTn transmitter and receiver pins respectively. The TXn and RXn pin function should first be selected by the corresponding pin-shared function selection register before the UARTn function is used. Along with the UARTE_{Nn} bit, the TXEN_n and RXEN_n bits, if set, will setup these pins to their respective TXn output and RXn input conditions and disable any pull-high resistor option which may exist on the TXn pin, and the internal pull-high resistor related to the receiver input pin is controlled by the corresponding I/O pull-high function control bit. When the TXn or RXn pin function is disabled by clearing the UARTE_{Nn}, TXEN_n or RXEN_n bit, the TXn or RXn pin will be set to a floating state. At this time whether the internal pull-high resistor is connected to the TXn or RXn pin or not is determined by the corresponding I/O pull-high function control bit.

UART Data Transfer Scheme

The above block diagram shows the overall data transfer structure arrangement for the UARTn. The actual data to be transmitted from the MCU is first transferred to the TXR_RXR_n register by the application program. The data will then be transferred to the Transmit Shift Register from where it will be shifted out, LSB first, onto the TXn pin at a rate controlled by the Baud Rate Generator. Only

the TXR_RXRn register is mapped onto the MCU Data Memory, the Transmit Shift Register is not mapped and is therefore inaccessible to the application program.

Data to be received by the UARTn is accepted on the external RXn pin, from where it is shifted in, LSB first, to the Receiver Shift Register at a rate controlled by the Baud Rate Generator. When the shift register is full, the data will then be transferred from the shift register to the internal TXR_RXRn register, where it is buffered and can be manipulated by the application program. Only the TXR_RXRn register is mapped onto the MCU Data Memory, the Receiver Shift Register is not mapped and is therefore inaccessible to the application program.

It should be noted that the actual register for data transmission and reception only exists as a single shared register, TXR_RXRn, in the Data Memory.

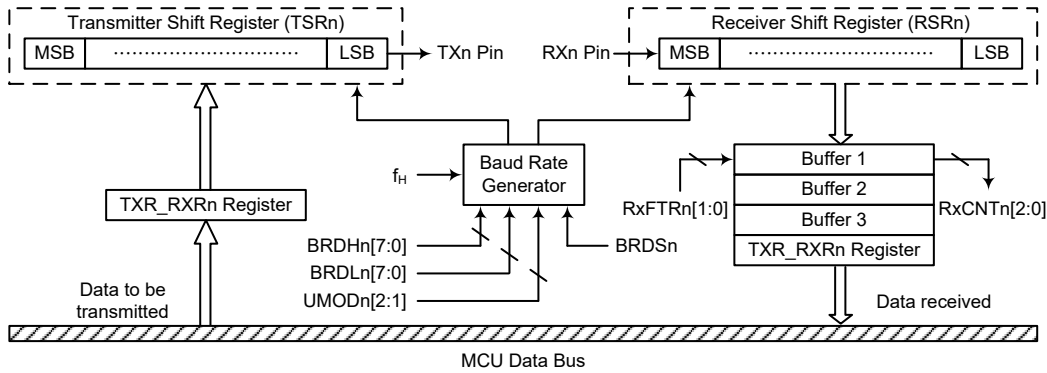

UARTn Data Transfer Block Diagram (n=0~1)

UART Status and Control Registers

There are eight control registers associated with the UARTn function. The UnSR, UnCR1, UnCR2, UFCRn and RxCNTn registers control the overall function of the UARTn, while the BRDHn and BRDLn registers control the Baud rate. The actual data to be transmitted and received on the serial interface is managed through the TXR_RXRn data register.

Register Name	Bit							
	7	6	5	4	3	2	1	0
UnSR	PERRn	NFn	FERRn	OERRn	RIDLEn	RXIFn	TIDLEn	TXIFn
UnCR1	UARTENn	BNOn	PRENn	PRTn1	PRTn0	TXBRKn	RX8n	TX8n
UnCR2	TXENn	RXENn	STOPSn	ADDENn	WAKEn	RIEn	TIIEn	TEIEn
TXR_RXRn	D7	D6	D5	D4	D3	D2	D1	D0
BRDHn	D7	D6	D5	D4	D3	D2	D1	D0
BRDLn	D7	D6	D5	D4	D3	D2	D1	D0
UFCRn	—	—	UMODn2	UMODn1	UMODn0	BRDSn	RxFTRn1	RxFTRn0
RxCNTn	—	—	—	—	—	D2	D1	D0

UARTn Register List (n=0~1)

• UnSR Register

The UnSR register is the status register for the UARTn, which can be read by the program to determine the present status of the UARTn. All flags within the UnSR register are read only. Further explanation on each of the flags is given below:

Bit	7	6	5	4	3	2	1	0
Name	PERRn	NFn	FERRn	OERRn	RIDLEn	RXIFn	TIDLEn	TXIFn
R/W	R	R	R	R	R	R	R	R
POR	0	0	0	0	1	0	1	1

Bit 7 PERRn: Parity error flag

- 0: No parity error is detected
- 1: Parity error is detected

The PERRn flag is the parity error flag. When this read only flag is “0”, it indicates a parity error has not been detected. When the flag is “1”, it indicates that the parity of the received word is incorrect. This error flag is applicable only if the parity is enabled and the parity type (odd, even, mark or space) is selected. The flag can also be cleared by a software sequence which involves a read to the status register UnSR followed by an access to the TXR_RXRn data register.

Bit 6 NFn: Noise flag

- 0: No noise is detected
- 1: Noise is detected

The NFn flag is the noise flag. When this read only flag is “0”, it indicates no noise condition. When the flag is “1”, it indicates that the UARTn has detected noise on the receiver input. The NFn flag is set during the same cycle as the RXIFn flag but will not be set in the case of an overrun. The NFn flag can be cleared by a software sequence which will involve a read to the status register UnSR followed by an access to the TXR_RXRn data register.

Bit 5 FERRn: Framing error flag

- 0: No framing error is detected
- 1: Framing error is detected

The FERRn flag is the framing error flag. When this read only flag is “0”, it indicates that there is no framing error. When the flag is “1”, it indicates that a framing error has been detected for the current character. The flag can also be cleared by a software sequence which will involve a read to the status register UnSR followed by an access to the TXR_RXRn data register.

Bit 4 OERRn: Overrun error flag

- 0: No overrun error is detected
- 1: Overrun error is detected

The OERRn flag is the overrun error flag which indicates when the receiver buffer has overflowed. When this read only flag is “0”, it indicates that there is no overrun error. When the flag is “1”, it indicates that an overrun error occurs which will inhibit further transfers to the TXR_RXRn receive data register. The flag is cleared by a software sequence, which is a read to the status register UnSR followed by an access to the TXR_RXRn data register.

Bit 3 RIDLEn: Receiver status

- 0: Data reception is in progress (Data being received)
- 1: No data reception is in progress (Receiver is idle)

The RIDLEn flag is the receiver status flag. When this read only flag is “0”, it indicates that the receiver is between the initial detection of the start bit and the completion of the stop bit. When the flag is “1”, it indicates that the receiver is idle. Between the completion of the stop bit and the detection of the next start bit, the RIDLEn bit is “1” indicating that the UARTn receiver is idle and the RXn pin stays in logic high condition.

- Bit 2** **RXIFn:** Receive TXR_RXRn data register status
 0: TXR_RXRn data register is empty
 1: TXR_RXRn data register has available data and reach Receiver FIFO trigger level
 The RXIFn flag is the receive data register status flag. When this read only flag is “0”, it indicates that the TXR_RXRn read data register is empty. When the flag is “1”, it indicates that the TXR_RXRn read data register contains new data. When the contents of the shift register are transferred to the TXR_RXRn register, and reach Receiver FIFO trigger level, an interrupt is generated if RIEn=1 in the UnCR2 register. If one or more errors are detected in the received word, the appropriate receive-related flags NF_n, FERR_n, and/or PERR_n are set within the same clock cycle. The RXIFn flag is cleared when the UnSR register is read with RXIFn set, followed by a read from the TXR_RXRn register, and if the TXR_RXRn register has no data available.
- Bit 1** **TIDLEn:** Transmission idle
 0: Data transmission is in progress (Data being transmitted)
 1: No data transmission is in progress (Transmitter is idle)
 The TIDLEn flag is known as the transmission complete flag. When this read only flag is “0”, it indicates that a transmission is in progress. This flag will be set high when the TXIFn flag is “1” and when there is no transmit data or break character being transmitted. When TIDLEn is equal to “1”, the TX_n pin becomes idle with the pin state in logic high condition. The TIDLEn flag is cleared by reading the UnSR register with TIDLEn set and then writing to the TXR_RXRn register. The flag is not generated when a data character or a break is queued and ready to be sent.
- Bit 0** **TXIFn:** Transmit TXR_RXRn data register status
 0: Character is not transferred to the transmit shift register
 1: Character has transferred to the transmit shift register (TXR_RXRn data register is empty)
 The TXIFn flag is the transmit data register empty flag. When this read only flag is “0”, it indicates that the character is not transferred to the transmitter shift register. When the flag is “1”, it indicates that the transmitter shift register has received a character from the TXR_RXRn data register. The TXIFn flag is cleared by reading the UARTn status register (UnSR) with TXIFn set and then writing to the TXR_RXRn data register. Note that when the TXENn bit is set, the TXIFn flag bit will also be set since the transmit data register is not yet full.

• **UnCR1 Register**

The UnCR1 register together with the UnCR2 register are the two UARTn control registers that are used to set the various options for the UARTn function, such as overall on/off control, parity control, data transfer bit length etc. Further explanation on each of the bits is given below:

Bit	7	6	5	4	3	2	1	0
Name	UARTENn	BNO _n	PREN _n	PRTn1	PRTn0	TXBRKn	RX8 _n	TX8 _n
R/W	R/W	R/W	R/W	R/W	R/W	R/W	R	W
POR	0	0	0	0	0	0	x	0

“x”: Unknown

- Bit 7** **UARTENn:** UARTn function enable control
 0: Disable UARTn. TX_n and RX_n pins are in a floating state
 1: Enable UARTn. TX_n and RX_n pins function as UARTn pins
 The UARTENn bit is the UARTn enable bit. When this bit is equal to “0”, the UARTn will be disabled and the RX_n pin as well as the TX_n pin will be set in a floating state. When the bit is equal to “1”, the UARTn will be enabled and the TX_n and RX_n pins will function as defined by the TXENn and RXENn enable control bits.
 When the UARTn is disabled, it will empty the buffer so any character remaining in the buffer will be discarded. In addition, the value of the baud rate counter will be reset. If the UARTn is disabled, all error and status flags will be reset. Also the TXENn, RXENn, TXBRKn, RXIFn, OERRn, FERRn, PERRn and NF_n bits will be

cleared, while the TIDLEn, TXIFn and RIDLEn bits will be set. Other control bits in UnCR1, UnCR2, BRDHn and BRDLn registers will remain unaffected. If the UARTn is active and the UARTEEn bit is cleared, all pending transmissions and receptions will be terminated and the module will be reset as defined above. When the UARTn is re-enabled, it will restart in the same configuration.

- Bit 6** **BNO_n**: Number of data transfer bits selection
 0: 8-bit data transfer
 1: 9-bit data transfer
- This bit is used to select the data length format, which can have a choice of either 8-bit or 9-bit format. When this bit is equal to “1”, a 9-bit data length format will be selected. If the bit is equal to “0”, then an 8-bit data length format will be selected. If 9-bit data length format is selected, then bits RX8n and TX8n will be used to store the 9th bit of the received and transmitted data respectively.
- Note that the 9th bit of data if BNO_n=1, or the 8th bit of data if BNO_n=0, which is used as the parity bit, does not transfer to RX8n or TXR_RXRn.7 respectively when the parity function is enabled.
- Bit 5** **PREN_n**: Parity function enable control
 0: Parity function is disabled
 1: Parity function is enabled
- This is the parity enable bit. When this bit is equal to “1”, the parity function will be enabled. If the bit is equal to “0”, then the parity function will be disabled.
- Bit 4~3** **PRTn1~PRTn0**: Parity type selection bits
 00: Even parity for parity generator
 01: Odd parity for parity generator
 10: Mark parity for parity generator
 11: Space parity for parity generator
- These bits are the parity type selection bits. When these bits are equal to 00b, even parity type will be selected. If these bits are equal to 01b, then odd parity type will be selected. If these bits are equal to 10b, Mark parity type will be selected. If these bits are equal to 11b, then Space parity type will be selected.
- Bit 2** **TXBRKn**: Transmit break character
 0: No break character is transmitted
 1: Break characters transmit
- The TXBRKn bit is the Transmit Break Character bit. When this bit is “0”, there are no break characters and the TXn pin operates normally. When the bit is “1”, there are transmit break characters and the transmitter will send logic zeros. When this bit is equal to “1”, after the buffered data has been transmitted, the transmitter output is held low for a minimum of a 13-bit length and until the TXBRKn bit is reset.
- Bit 1** **RX8n**: Receive data bit 8 for 9-bit data transfer format (read only)
- This bit is only used if 9-bit data transfers are used, in which case this bit location will store the 9th bit of the received data known as RX8n. The BNO_n bit is used to determine whether data transfers are in 8-bit or 9-bit format.
- Bit 0** **TX8n**: Transmit data bit 8 for 9-bit data transfer format (write only)
- This bit is only used if 9-bit data transfers are used, in which case this bit location will store the 9th bit of the transmitted data known as TX8n. The BNO_n bit is used to determine whether data transfers are in 8-bit or 9-bit format.

• **UnCR2 Register**

The UnCR2 register is the second of the two UARTn control registers and serves several purposes. One of its main functions is to control the basic enable/disable operation of the UARTn Transmitter and Receiver as well as enabling the various UARTn interrupts sources. The register also serves to control the STOP bit number selection, receiver wake-up enable and the address detect enable. Further explanation on each of the bits is given below:

Bit	7	6	5	4	3	2	1	0
Name	TXENn	RXENn	STOPSn	ADDENn	WAKEn	RIEn	TIIEEn	TEIEEn
R/W	R/W	R/W	R/W	R/W	R/W	R/W	R/W	R/W
POR	0	0	0	0	0	0	0	0

Bit 7 **TXENn**: UARTn transmitter enabled control

- 0: UARTn transmitter is disabled
- 1: UARTn transmitter is enabled

The bit named TXENn is the Transmitter Enable Bit. When this bit is equal to “0”, the transmitter will be disabled with any pending data transmissions being aborted. In addition the buffers will be reset. In this situation the TXn pin will be set in a floating state.

If the TXENn bit is equal to “1” and the UARTENn bit are also equal to “1”, the transmitter will be enabled and the TXn pin will be controlled by the UARTn. Clearing the TXENn bit during a transmission will cause the data transmission to be aborted and will reset the transmitter. If this situation occurs, the TXn pin will be set in a floating state.

Bit 6 **RXENn**: UARTn Receiver enabled control

- 0: UARTn receiver is disabled
- 1: UARTn receiver is enabled

The bit named RXENn is the Receiver Enable Bit. When this bit is equal to “0”, the receiver will be disabled with any pending data receptions being aborted. In addition the receive buffers will be reset. In this situation the RXn pin will be set in a floating state. If the RXENn bit is equal to “1” and the UARTENn bit is also equal to “1”, the receiver will be enabled and the RXn pin will be controlled by the UARTn. Clearing the RXENn bit during a reception will cause the data reception to be aborted and will reset the receiver. If this situation occurs, the RXn pin will be set in a floating state.

Bit 5 **STOPSn**: Number of stop bits selection for transmitter

- 0: One stop bit format is used
- 1: Two stop bits format is used

This bit determines if one or two stop bits are to be used for transmitter. When this bit is equal to “1”, two stop bits are used. If this bit is equal to “0”, then only one stop bit is used.

Bit 4 **ADDENn**: Address detect function enable control

- 0: Address detect function is disabled
- 1: Address detect function is enabled

The bit named ADDENn is the address detect function enable control bit. When this bit is equal to “1”, the address detect function is enabled. When it occurs, if the 8th bit, which corresponds to TXR_RXRn.7 if BNO=0 or the 9th bit, which corresponds to RX8n if BNO=1, has a value of “1”, then the received word will be identified as an address, rather than data. If the corresponding interrupt is enabled, an interrupt request will be generated each time the received word has the address bit set, which is the 8th or 9th bit depending on the value of BNO. If the address bit known as the 8th or 9th bit of the received word is “0” with the address detect function being enabled, an interrupt will not be generated and the received data will be discarded.

- Bit 3 **WAKEn:** RXn pin wake-up UARTn function enable control
 0: RXn pin wake-up UARTn function is disabled
 1: RXn pin wake-up UARTn function is enabled
 This bit is used to control the wake-up UARTn function when a falling edge on the RXn pin occurs. Note that this bit is only available when the UARTn clock (f_{H1}) is switched off. There will be no RXn pin wake-up UARTn function if the UARTn clock (f_{H1}) exists. If the WAKEn bit is set to 1 as the UARTn clock (f_{H1}) is switched off, a UARTn wake-up request will be initiated when a falling edge on the RXn pin occurs. When this request happens and the corresponding interrupt is enabled, an RXn pin wake-up UARTn interrupt will be generated to inform the MCU to wake up the UARTn function by switching on the UARTn clock (f_{H1}) via the application program. Otherwise, the UARTn function cannot resume even if there is a falling edge on the RXn pin when the WAKEn bit is cleared to 0.
- Bit 2 **RIEn:** Receiver interrupt enable control
 0: Receiver related interrupt is disabled
 1: Receiver related interrupt is enabled
 This bit enables or disables the receiver interrupt. If this bit is equal to “1” and when the receiver overrun flag OERRn or receive data available flag RXIFn is set, the UARTn interrupt request flag will be set. If this bit is equal to “0”, the UARTn interrupt request flag will not be influenced by the condition of the OERRn or RXIFn flags.
- Bit 1 **TIEn:** Transmitter Idle interrupt enable control
 0: Transmitter idle interrupt is disabled
 1: Transmitter idle interrupt is enabled
 This bit enables or disables the transmitter idle interrupt. If this bit is equal to “1” and when the transmitter idle flag TIDLEn is set, due to a transmitter idle condition, the UARTn interrupt request flag will be set. If this bit is equal to “0”, the UARTn interrupt request flag will not be influenced by the condition of the TIDLEn flag.
- Bit 0 **TEIEn:** Transmitter Empty interrupt enable control
 0: Transmitter empty interrupt is disabled
 1: Transmitter empty interrupt is enabled
 This bit enables or disables the transmitter empty interrupt. If this bit is equal to “1” and when the transmitter empty flag TXIFn is set, due to a transmitter empty condition, the UARTn interrupt request flag will be set. If this bit is equal to “0”, the UARTn interrupt request flag will not be influenced by the condition of the TXIFn flag.

• **TXR_RXRn Register**

The TXR_RXRn register is the data register which is used to store the data to be transmitted on the TXn pin or being received from the RXn pin.

Bit	7	6	5	4	3	2	1	0
Name	D7	D6	D5	D4	D3	D2	D1	D0
R/W	R/W	R/W	R/W	R/W	R/W	R/W	R/W	R/W
POR	x	x	x	x	x	x	x	x

“x”: Unknown

- Bit 7~0 **D7~D0:** UARTn transmit/receive data bit 7 ~ bit 0

• **BRDHn Register**

Bit	7	6	5	4	3	2	1	0
Name	D7	D6	D5	D4	D3	D2	D1	D0
R/W	R/W	R/W	R/W	R/W	R/W	R/W	R/W	R/W
POR	0	0	0	0	0	0	0	0

Bit 7~0 **D7~D0**: Baud rate divider high byte
 The baud rate divider BRDn (BRDHn/BRDLn) defines the UARTn clock divider ratio.

$$\text{Baud Rate} = f_H / (\text{BRDn} + \text{UMODn}/8)$$

$$\text{BRDn} = 16 \sim 65535 \text{ or } 8 \sim 65535 \text{ depending on BRDSn}$$
 Note: 1. BRDn value should not be set to less than 16 when BRDSn=0 or less than 8 when BRDSn=1, otherwise errors may occur.
 2. The BRDLn must be written first and then BRDHn, otherwise errors may occur.

• **BRDLn Register**

Bit	7	6	5	4	3	2	1	0
Name	D7	D6	D5	D4	D3	D2	D1	D0
R/W	R/W	R/W	R/W	R/W	R/W	R/W	R/W	R/W
POR	0	0	0	0	0	0	0	0

Bit 7~0 **D7~D0**: Baud rate values low byte
 The baud rate divider BRDn (BRDHn/BRDLn) defines the UARTn clock divider ratio.

$$\text{Baud Rate} = f_H / (\text{BRDn} + \text{UMODn}/8)$$

$$\text{BRDn} = 16 \sim 65535 \text{ or } 8 \sim 65535 \text{ depending on BRDSn}$$
 Note: 1. BRDn value should not be set to less than 16 when BRDSn=0 or less than 8 when BRDSn=1, otherwise errors may occur.
 2. The BRDLn must be written first and then BRDHn, otherwise errors may occur.

• **UFCRn Register**

The UFCRn register is the FIFO control register which is used for UARTn modulation control, BRDn range selection and trigger level selection for RXIFn and interrupt.

Bit	7	6	5	4	3	2	1	0
Name	—	—	UMODn2	UMODn1	UMODn0	BRDSn	RxFTRn1	RxFTRn0
R/W	—	—	R/W	R/W	R/W	R/W	R/W	R/W
POR	—	—	0	0	0	0	0	0

Bit 7~6 Unimplemented, read as “0”
 Bit 5~3 **UMODn2~UMODn0**: UARTn Modulation Control bits
 The modulation control bits are used to correct the baud rate of the received or transmitted UARTn signal. These bits determine if the extra UARTn clock cycle should be added in a UARTn bit time. The UMODn2~UMODn0 will be added to internal accumulator for every UARTn bit time. Until a carry to bit 3, the corresponding UARTn bit time increases a UARTn clock cycle.
 Bit 2 **BRDSn**: BGDn range selection
 0: BRDn range is from 16 to 65535
 1: BRDn range is from 8 to 65535
 The BRDSn is used to control the sampling point in a UARTn bit time. If the BRDSn is cleared to zero, the sampling point will be $\text{BRDn}/2$, $\text{BRDn}/2 + 1 \times f_H$, and $\text{BRDn}/2 + 2 \times f_H$ in a UARTn bit time. If the BRDSn is set high, the sampling point will be $\text{BRDn}/2 - 1 \times f_H$, $\text{BRDn}/2$, and $\text{BRDn}/2 + 2 \times f_H$ in a UARTn bit time.

- Bit 1~0 **RxFTRn1~RxFTRn0**: Receiver FIFO trigger level (bytes)
 00: 4 bytes in Receiver FIFO
 01: 1 or more bytes in Receiver FIFO
 10: 2 or more bytes in Receiver FIFO
 11: 3 or more bytes in Receiver FIFO

For the receiver these bits define the number of received data bytes in the Receiver FIFO that will trigger the RXIFn bit being set high, an interrupt will also be generated if the RIEn bit is enabled. After the reset the receiver FIFO is empty.

• RxCNTn Register

The RxCNTn register is the counter used to indicate the number of received data bytes in the Receiver FIFO which have not been read by the MCU. This register is read only.

Bit	7	6	5	4	3	2	1	0
Name	—	—	—	—	—	D2	D1	D0
R/W	—	—	—	—	—	R	R	R
POR	—	—	—	—	—	0	0	0

Bit 7~3 Unimplemented, read as “0”

Bit 2~0 **D2~D0**: Receiver FIFO counter

The RxCNTn register is the counter used to indicate the number of receiver data bytes in Receiver FIFO which is not read by MCU. When Receiver FIFO receives one byte data, the RxCNTn will increase by one; when the MCU reads one byte data from Receiver FIFO, the RxCNTn will decrease by one. If there are 4 bytes of data in the Receiver FIFO, the 5th data will be saved in the shift register. If there is 6th data, the 6th data will be saved in the shift register. But the RxCNTn remains the value of 4. The RxCNTn will be cleared when reset occurs or UARTENn=1. This register is read only.

Baud Rate Generator

To setup the speed of the serial data communication, the UARTn function contains its own dedicated baud rate generator. The baud rate is controlled by its own internal free running 16-bit timer, the period of which is determined by two factors. The first of these is the value placed in the BRDHn/BRDLn register and the second is the UARTn modulation control bits, UMODn2~UMODn0. If a baud rate BR is required with UARTn clock f_H .

$$f_H/BR = \text{Integer Part} + \text{Fractional Part}$$

The integer part is loaded into BRDn (BRDHn/BRDLn). The fractional part is multiplied by 8 and rounded, then loaded into UMODn bit field as following:

$$BRDn = \text{TRUNC}(f_H/BR)$$

$$UMODn = \text{ROUND}[\text{MOD}(f_H/BR) \times 8]$$

Therefore, the actual baud rate is as following:

$$\text{Baud rate} = f_H / [BRDn + (UMODn/8)]$$

Calculating the Baud Rate and Error Values

For a clock frequency of 4MHz, determine the BRDHn/BRDLn register value, the actual baud rate and the error value for a desired baud rate of 230400.

From the above formula, the $BRDn = \text{TRUNC}(f_H/BR) = \text{TRUNC}(17.36111) = 17$

The $UMODn = \text{ROUND}[\text{MOD}(f_H/BR) \times 8] = \text{ROUND}(0.36111 \times 8) = \text{ROUND}(2.88888) = 3$

The actual Baud Rate $= f_H / [BRDn + (UMODn/8)] = 230215.83$

Therefore the error is equal to $(230215.83 - 230400) / 230400 = -0.08\%$

Modulation Control Example

To get the best-fitting bit sequence for UARTn modulation control bits UMODn2~UMODn0, the following algorithm can be used: Firstly, the fractional part of the theoretical division factor is multiplied by 8. Then the product will be rounded and UMODn2~UMODn0 bits will be filled with the rounded value. The UMODn2~UMODn0 will be added to internal accumulator for every UARTn bit time. Until a carry to bit 3, the corresponding UARTn bit time increases a UARTn clock cycle. The following is an example using the fraction 0.36111 previously calculated: UMODn[2:0]=ROUND(0.36111×8)=011b.

Fraction Addition	Carry to Bit 3	UARTn Bit Time Sequence	Extra UARTn Clock Cycle
0000b+0011b=0011b	No	Start bit	No
0011b+0011b=0110b	No	D0	No
0110b+0011b=1001b	Yes	D1	Yes
1001b+0011b=1100b	No	D2	No
1100b+0011b=1111b	No	D3	No
1111b+0011b=0010b	Yes	D4	Yes
0010b+0011b=0101b	No	D5	No
0101b+0011b=1000b	Yes	D6	Yes
1000b+0011b=1011b	No	D7	No
1011b+0011b=1110b	No	Parity bit	No
1110b+0011b=0001b	Yes	Stop bit	Yes

Baud Rate Correction Example

The following figure presents an example using a baud rate of 230400 generated with UARTn clock f_H . The data format for the following figure is: eight data bits, parity enabled, no address bit, two stop bits.

The following figure shows three different frames:

- The upper frame is the correct one, with a bit-length of 17.36 f_H cycles ($4000000/230400=17.36$).
- The middle frame uses a rough estimate, with 17 f_H cycles for the bit length.
- The lower frame shows a corrected frame using the best fit for the UARTn modulation control bits UMODn2~UMODn0.

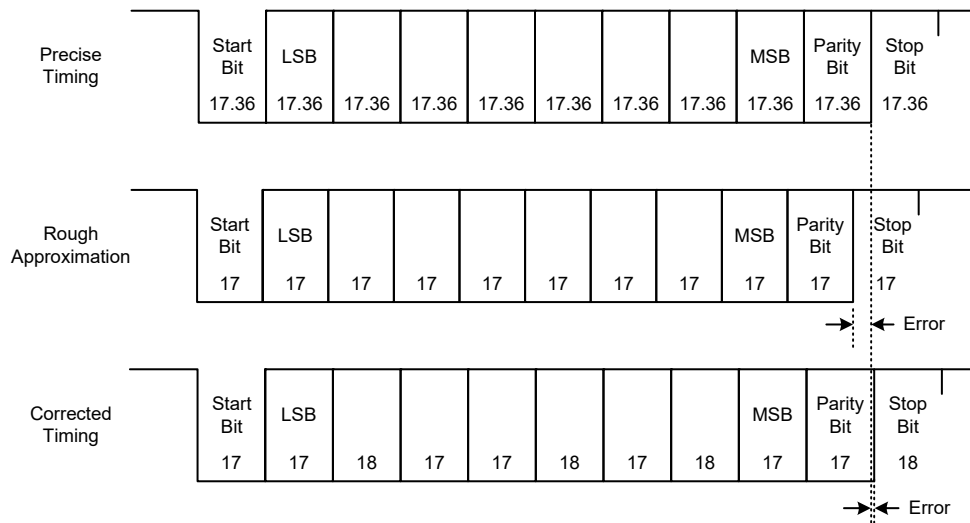

UART Setup and Control

For data transfer, the UARTn function utilizes a non-return-to-zero, more commonly known as NRZ, format. This is composed of one start bit, eight or nine data bits, and one or two stop bits. Parity is supported by the UARTn hardware, and can be setup to be even, odd, mark, space or no parity. For the most common data format, 8 data bits along with no parity and one stop bit, denoted as 8, N, 1, is used as the default setting, which is the setting at power-on. The number of data bits and stop bits, along with the parity, are setup by programming the corresponding BNO_n, PRTn1~PRTn0, PREN_n, and STOPS_n bits. The baud rate used to transmit and receive data is setup using the internal 16-bit baud rate generator, while the data is transmitted and received LSB first. Although the UARTn transmitter and receiver are functionally independent, they both use the same data format and baud rate. In all cases stop bits will be used for data transmission.

Enabling/Disabling the UART Interface

The basic on/off function of the internal UARTn function is controlled using the UARTEN_n bit in the UnCR1 register. If the UARTEN_n, TXEN_n and RXEN_n bits are set, then these two UARTn pins will act as normal TX_n output pin and RX_n input pin respectively. If no data is being transmitted on the TX_n pin, then it will default to a logic high value.

Clearing the UARTEN_n bit will disable the TX_n and RX_n pins and allow these two pins to be used as normal I/O or other pin-shared functional pins by configuring the corresponding pin-shared control bits. When the UARTn function is disabled the buffer will be reset to an empty condition, at the same time discarding any remaining residual data. Disabling the UARTn will also reset the error and status flags with bits TXEN_n, RXEN_n, TXBRK_n, RXIF_n, OERR_n, FERR_n, PERR_n and NFN_n being cleared while bits TIDLE_n, TXIF_n and RIDLE_n will be set. The remaining control bits in the UnCR1, UnCR2, BRDH_n and BRDL_n registers will remain unaffected. If the UARTEN_n bit in the UnCR1 register is cleared while the UARTn is active, then all pending transmissions and receptions will be immediately suspended and the UARTn will be reset to a condition as defined above. If the UARTn is then subsequently re-enabled, it will restart again in the same configuration.

Data, Parity and Stop Bit Selection

The format of the data to be transferred is composed of various factors such as data bit length, parity on/off, parity type, address bits and the number of stop bits. These factors are determined by the setup of various bits within the UnCR1 and UnCR2 registers. The BNO_n bit controls the number of data bits which can be set to either 8 or 9, the PRTn1~PRTn0 bits control the choice of odd, even, mark or space parity, the PREN_n bit controls the parity on/off function and the STOPS_n bit decides whether one or two stop bits are to be used. The following table shows various formats for data transmission. The address bit, which is the MSB of the data byte, identifies the frame as an address character or data if the address detect function is enabled. The number of stop bits, which can be either one or two, is independent of the data length and is only used for the transmitter. There only to be one stop bit for the receiver.

Start Bit	Data Bits	Address Bit	Parity Bit	Stop Bit
Example of 8-bit Data Formats				
1	8	0	0	1
1	7	0	1	1
1	7	1	0	1
Example of 9-bit Data Formats				
1	9	0	0	1
1	8	0	1	1
1	8	1	0	1

Transmitter Receiver Data Format

The following diagram shows the transmit and receive waveforms for both 8-bit and 9-bit data formats.

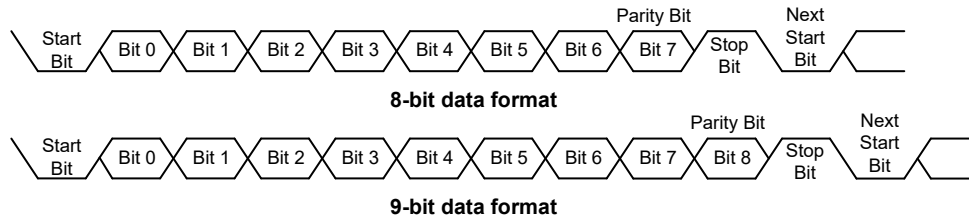

UART Transmitter

Data word lengths of either 8 or 9 bits can be selected by programming the BNO_n bit in the UnCR1 register. When BNO_n bit is set, the word length will be set to 9 bits. In this case the 9th bit, which is the MSB, needs to be stored in the TX8_n bit in the UnCR1 register. At the transmitter core lies the Transmitter Shift Register, more commonly known as the TSR_n, whose data is obtained from the transmit data register, which is known as the TXR_RXR_n register. The data to be transmitted is loaded into this TXR_RXR_n register by the application program. The TSR_n register is not written to with new data until the stop bit from the previous transmission has been sent out. As soon as this stop bit has been transmitted, the TSR_n can then be loaded with new data from the TXR_RXR_n register, if it is available. It should be noted that the TSR_n register, unlike many other registers, is not directly mapped into the Data Memory area and as such is not available to the application program for direct read/write operations. An actual transmission of data will normally be enabled when the TXEN_n bit is set, but the data will not be transmitted until the TXR_RXR_n register has been loaded with data and the baud rate generator has defined a shift clock source. However, the transmission can also be initiated by first loading data into the TXR_RXR_n register, after which the TXEN_n bit can be set. When a transmission of data begins, the TSR_n is normally empty, in which case a transfer to the TXR_RXR_n register will result in an immediate transfer to the TSR_n. If during a transmission the TXEN_n bit is cleared, the transmission will immediately cease and the transmitter will be reset. The TX_n output pin can then be configured as the I/O or other pin-shared functions by configuring the corresponding pin-shared control bits.

Transmitting Data

When the UART_n is transmitting data, the data is shifted on the TX_n pin from the shift register, with the least significant bit first. In the transmit mode, the TXR_RXR_n register forms a buffer between the internal bus and the transmitter shift register. It should be noted that if 9-bit data format has been selected, then the MSB will be taken from the TX8_n bit in the UnCR1 register. The steps to initiate a data transfer can be summarized as follows:

- Make the correct selection of the BNO_n, PRT_{n1}~PRT_{n0}, PREN_n and STOPS_n bits to define the required word length, parity type and the number of stop bits.
- Setup the BRDH_n, BRDL_n registers and the UMOD_{n2}~UMOD_{n0} bits to select the desired baud rate.
- Set the TXEN_n bit to ensure that the TX_n pin is used as a UART_n transmitter pin.
- Access the UnSR register and write the data that is to be transmitted into the TXR_RXR_n register. Note that this step will clear the TXIF_n bit.

This sequence of events can now be repeated to send additional data.

It should be noted that when TXIF_n=0, data will be inhibited from being written to the TXR_RXR_n register. Clearing the TXIF_n flag is always achieved using the following software sequence:

1. A UnSR register access
2. A TXR_RXRn register write execution

The read-only TXIFn flag is set by the UARTn hardware and if set indicates that the TXR_RXRn register is empty and that other data can now be written into the TXR_RXRn register without overwriting the previous data. If the TEIE n bit is set then the TXIFn flag will generate an interrupt.

During a data transmission, a write instruction to the TXR_RXRn register will place the data into the TXR_RXRn register, which will be copied to the shift register at the end of the present transmission. When there is no data transmission in progress, a write instruction to the TXR_RXRn register will place the data directly into the shift register, resulting in the commencement of data transmission, and the TXIFn bit being immediately set. When a frame transmission is complete, which happens after stop bits are sent or after the break frame, the TIDLE n bit will be set. To clear the TIDLE n bit the following software sequence is used:

1. A UnSR register access
2. A TXR_RXRn register write execution

Note that both the TXIFn and TIDLE n bits are cleared by the same software sequence.

Transmitting Break

If the TXBRKn bit is set and the state keeps for a time greater than $(BRDn+1) \times t_{th}$ while TIDLE n=1, then break characters will be sent on the next transmission. Break character transmission consists of a start bit, followed by $13 \times N$ '0' bits and stop bits, where $N=1, 2, \text{etc.}$ If a break character is to be transmitted then the TXBRKn bit must be first set by the application program, and then cleared to generate the stop bits. Transmitting a break character will not generate a transmit interrupt. Note that a break condition length is at least 13 bits long. If the TXBRKn bit is continually kept at a logic high level then the transmitter circuitry will transmit continuous break characters. After the application program has cleared the TXBRKn bit, the transmitter will finish transmitting the last break character and subsequently send out one or two stop bits. The automatic logic highs at the end of the last break character will ensure that the start bit of the next frame is recognized.

UART Receiver

The UARTn is capable of receiving word lengths of either 8 or 9 bits. If the BNO n bit is set, the word length will be set to 9 bits with the MSB being stored in the RX8n bit of the UnCR1 register. At the receiver core lies the Receive Serial Shift Register, commonly known as the RSRn. The data which is received on the RXn external input pin is sent to the data recovery block. The data recovery block operating speed is 16 times that of the baud rate, while the main receive serial shifter operates at the baud rate. After the RXn pin is sampled for the stop bit, the received data in RSRn is transferred to the receive data register, if the register is empty. The data which is received on the external RXn input pin is sampled three times by a majority detect circuit to determine the logic level that has been placed onto the RXn pin. It should be noted that the RSRn register, unlike many other registers, is not directly mapped into the Data Memory area and as such is not available to the application program for direct read/write operations.

Receiving Data

When the UARTn receiver is receiving data, the data is serially shifted in on the external RXn input pin, LSB first. In the read mode, the TXR_RXRn register forms a buffer between the internal bus and the receiver shift register. The TXR_RXRn register is a four byte deep FIFO data buffer, where four bytes can be held in the FIFO while a fifth byte can continue to be received. Note that the application program must ensure that the data is read from TXR_RXRn before the fifth byte has been completely shifted in, otherwise this fifth byte will be discarded and an overrun error OERRn will be subsequently indicated. The steps to initiate a data transfer can be summarized as follows:

- Make the correct selection of BNO_n, PRTn1~PRTn0 and PREN_n bits to define the word length and parity type.
- Setup the BRDH_n, BRDL_n registers and the UMODn2~UMODn0 bits to select the desired baud rate.
- Set the RXEN_n bit to ensure that the RX_n pin is used as a UART_n receiver pin.

At this point the receiver will be enabled which will begin to look for a start bit.

When a character is received the following sequence of events will occur:

- The RXIF_n bit in the UnSR register will be set when the TXR_RXR_n register has data available. the number of the available data bytes can be checked by polling the RxCNT_n register content.
- When the contents of the shift register have been transferred to the TXR_RXR_n register and reach Receiver FIFO trigger level, if the RIEN bit is set, then an interrupt will be generated.
- If during reception, a frame error, noise error, parity error, or an overrun error has been detected, then the error flags can be set.

The RXIF_n bit can be cleared using the following software sequence:

1. A UnSR register access
2. A TXR_RXR_n register read execution

Receiving Break

Any break character received by the UART_n will be managed as a framing error. The receiver will count and expect a certain number of bit times as specified by the values programmed into the BNO_n bit plus one stop bit. If the break is much longer than 13 bit times, the reception will be considered as complete after the number of bit times specified by BNO_n plus one stop bit. The RXIF_n bit is set, FERR_n is set, zeros are loaded into the receive data register, interrupts are generated if appropriate and the RIDLE_n bit is set. A break is regarded as a character that contains only zeros with the FERR_n flag set. If a long break signal has been detected, the receiver will regard it as a data frame including a start bit, data bits and the invalid stop bit and the FERR_n flag will be set. The receiver must wait for a valid stop bit before looking for the next start bit. The receiver will not make the assumption that the break condition on the line is the next start bit. The break character will be loaded into the buffer and no further data will be received until stop bits are received. It should be noted that the RIDLE_n read only flag will go high when the stop bits have not yet been received. The reception of a break character on the UART_n registers will result in the following:

- The framing error flag, FERR_n, will be set.
- The receive data register, TXR_RXR_n, will be cleared.
- The OERR_n, NF_n, PERR_n, RIDLE_n or RXIF_n flags will possibly be set.

Idle Status

When the receiver is reading data, which means it will be in between the detection of a start bit and the reading of a stop bit, the receiver status flag in the UnSR register, otherwise known as the RIDLE_n flag, will have a zero value. In between the reception of a stop bit and the detection of the next start bit, the RIDLE_n flag will have a high value, which indicates the receiver is in an idle condition.

Receiver Interrupt

The read only receive interrupt flag RXIF_n in the UnSR register is set by an edge generated by the receiver. An interrupt is generated if RIEN=1, when a word is transferred from the Receive Shift Register, RSR_n, to the Receive Data Register, TXR_RXR_n. An overrun error can also generate an interrupt if RIEN=1.

Managing Receiver Errors

Several types of reception errors can occur within the UARTn module, the following section describes the various types and how they are managed by the UARTn.

Overflow Error – OERRn

The TXR_RXRn register is composed of a four byte deep FIFO data buffer, where four bytes can be held in the FIFO register, while a fifth byte can continue to be received. Before this fifth byte has been entirely shifted in, the data should be read from the TXR_RXRn register. If this is not done, the overflow error flag OERRn will be consequently indicated.

In the event of an overflow error occurring, the following will happen:

- The OERRn flag in the UnSR register will be set.
- The TXR_RXRn contents will not be lost.
- The shift register will be overwritten.
- An interrupt will be generated if the RIEn bit is set.

The OERRn flag can be cleared by an access to the UnSR register followed by a read to the TXR_RXRn register.

Noise Error – NFn

Over-sampling is used for data recovery to identify valid incoming data and noise. If noise is detected within a frame the following will occur:

- The read only noise flag, NFn, in the UnSR register will be set on the rising edge of the RXIFn bit.
- Data will be transferred from the Shift register to the TXR_RXRn register.
- No interrupt will be generated. However this bit rises at the same time as the RXIFn bit which itself generates an interrupt.

Note that the NFn flag is reset by a UnSR register read operation followed by a TXR_RXRn register read operation.

Framing Error – FERRn

The read only framing error flag, FERRn, in the UnSR register, is set if a zero is detected instead of stop bits. If two stop bits are selected, both stop bits must be high; otherwise the FERRn flag will be set. The FERRn flag and the received data will be recorded in the UnSR and TXR_RXRn registers respectively, and the flag is cleared in any reset.

Parity Error – PERRn

The read only parity error flag, PERRn, in the UnSR register, is set if the parity of the received word is incorrect. This error flag is only applicable if the parity is enabled, PRENn=1, and if the parity type, odd, even, mark or space, is selected. The read only PERRn flag and the received data will be recorded in the UnSR and TXR_RXRn registers respectively. It is cleared on any reset, it should be noted that the flags, FERRn and PERRn, in the UnSR register should first be read by the application program before reading the data word.

UART Interrupt Structure

Several individual UARTn conditions can generate a UARTn interrupt. When these conditions exist, a low pulse will be generated to get the attention of the microcontroller. These conditions are a transmitter data register empty, transmitter idle, receiver reaching FIFO trigger level, receiver overrun, address detect and an RXn pin wake-up. When any of these conditions are created, if the global interrupt enable bit, multi-function interrupt enable bit and its corresponding interrupt control

bit are enabled and the stack is not full, the program will jump to its corresponding interrupt vector where it can be serviced before returning to the main program. Four of these conditions have the corresponding UnSR register flags which will generate a UARTn interrupt if its associated interrupt enable control bit in the UnCR2 register is set. The two transmitter interrupt conditions have their own corresponding enable control bits, while the three receiver interrupt conditions have a shared enable control bit. These enable bits can be used to mask out individual UARTn interrupt sources.

The address detect condition, which is also a UARTn interrupt source, does not have an associated flag, but will generate a UARTn interrupt when an address detect condition occurs if its function is enabled by setting the ADDENn bit in the UnCR2 register. An RXn pin wake-up, which is also a UARTn interrupt source, does not have an associated flag, but will generate a UARTn interrupt if the UARTn clock (f_{HI}) source is switched off and the WAKEn and RIEn bits in the UnCR2 register are set when a falling edge on the RXn pin occurs.

Note that the UnSR register flags are read only and cannot be cleared or set by the application program, neither will they be cleared when the program jumps to the corresponding interrupt servicing routine, as is the case for some of the other interrupts. The flags will be cleared automatically when certain actions are taken by the UARTn, the details of which are given in the UARTn register section. The overall related interrupt can be disabled or enabled by the UARTn interrupt enable control bits in the interrupt control registers of the microcontroller to decide whether the interrupt requested by the UARTn module is masked out or allowed.

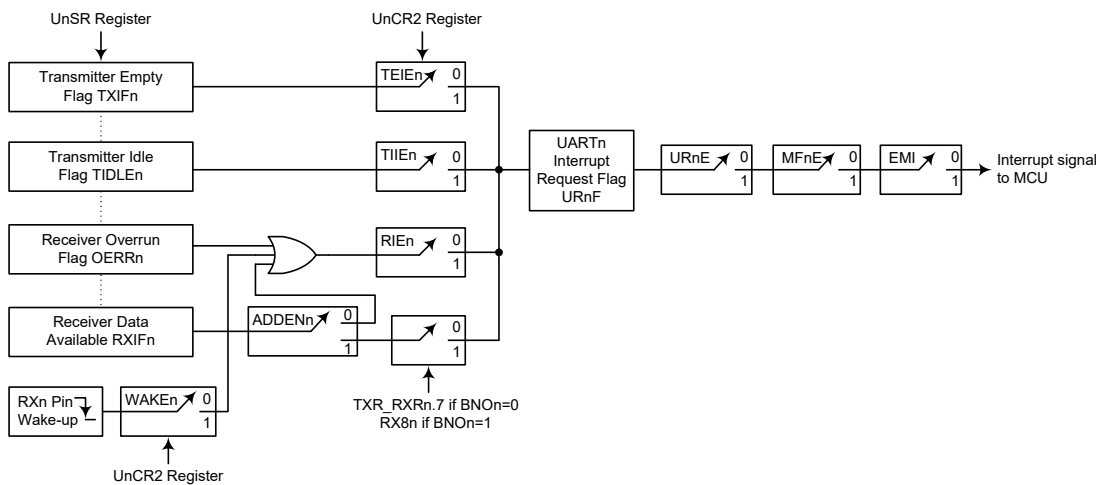

UARTn Interrupt Structure (n=0~1)

Address Detect Mode

Setting the Address Detect Mode bit, ADDENn, in the UnCR2 register, enables this special mode. If this bit is enabled then an additional qualifier will be placed on the generation of a Receiver Data Available interrupt, which is requested by the RXIFn flag. If the ADDENn bit is enabled, then when data is available, an interrupt will only be generated, if the highest received bit has a high value. Note that the URnE, MFnE and EMI interrupt enable bits must also be enabled for correct interrupt generation. This highest address bit is the 9th bit if BNO=1 or the 8th bit if BNO=0. If this bit is high, then the received word will be defined as an address rather than data. A Data Available interrupt will be generated every time the last bit of the received word is set. If the ADDENn bit is not enabled, then a Receiver Data Available interrupt will be generated each time the RXIFn flag is set, irrespective of the data last bit status. The address detect mode and parity enable are mutually exclusive functions. Therefore if the address detect mode is enabled, then to ensure correct operation, the parity function should be disabled by resetting the parity enable bit PRENn to zero.

ADDENn	9th bit if BNO _n =1 8th bit if BNO _n =0	UARTn Interrupt Generated
0	0	√
	1	√
1	0	×
	1	√

ADDENn Bit Function

UART Power Down and Wake-up

When the UART_n clock (f_{H}) is off, the UART_n will cease to function, all clock sources to the module are shutdown. If the UART_n clock (f_{H}) is off while a transmission is still in progress, then the transmission will be paused until the UART_n clock source derived from the microcontroller is activated. In a similar way, if the MCU enters the IDLE or SLEEP mode while receiving data, then the reception of data will likewise be paused. When the MCU enters the IDLE or SLEEP mode, note that the UnSR, UnCR1, UnCR2, transmit and receive registers, as well as the BRDH_n and BRDL_n registers will not be affected. It is recommended to make sure first that the UART_n data transmission or reception has been finished before the microcontroller enters the IDLE or SLEEP mode.

The UART_n function contains a receiver RX_n pin wake-up function, which is enabled or disabled by the WAKEN bit in the UnCR2 register. If this bit, along with the UART_n enable bit, UARTEN_n, the receiver enable bit, RXEN_n and the receiver interrupt bit, RIEN, are all set when the UART_n clock (f_{H}) is off, then a falling edge on the RX_n pin will trigger an RX_n pin wake-up UART_n interrupt. Note that as it takes certain system clock cycles after a wake-up, before normal microcontroller operation resumes, any data received during this time on the RX_n pin will be ignored.

For a UART_n wake-up interrupt to occur, in addition to the bits for the wake-up being set, the global interrupt enable bit, EMI, the multi-function interrupt enable bit, MFnE, and the UART_n interrupt enable bit, URnE, must be set. If the EMI and URnE bits are not set then only a wake up event will occur and no interrupt will be generated. Note also that as it takes certain system clock cycles after a wake-up before normal microcontroller resumes, the UART_n interrupt will not be generated until after this time has elapsed.

Comparators

One independent analog comparator is contained in this device. The comparator functions offer flexibility via their register controlled features such as power-down, polarity select, response time, etc. In sharing their pins with normal I/O pins the comparators do not waste precious I/O pins if the comparator functions are otherwise unused.

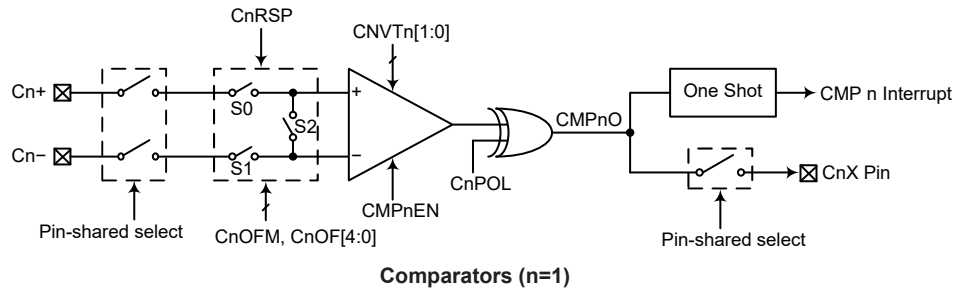

Comparator Operation

The device contains one comparator function which is used to compare two analog voltages and provide an output based on their difference. Full control over the internal comparators is provided via the control register, CMP1C. The comparator output is recorded via a bit in the control register, but can also be transferred out onto a shared I/O pin. Additional comparator functions include output polarity, response time and power down control.

Any pull-high resistors connected to the shared comparator input pins will be automatically disconnected when the comparator is enabled. As the comparator inputs approach their switching level, some spurious output signals may be generated on the comparator output due to the slow rising or falling nature of the input signals. This can be minimised by the hysteresis function which will apply a small amount of positive feedback to the comparator. When the comparator operates in the normal mode, the hysteresis function will automatically be enabled. However, the hysteresis function will be disabled when the comparator operates in the input offset calibration mode.

Ideally the comparator should switch at the point where the positive and negative inputs signals are at the same voltage level. However, unavoidable input offsets introduce some uncertainties here. The offset calibration function, if executed, will minimise the switching offset value. The comparators also provide the output response time select function using the CNVTn1~CNVTn0 bits in the CMPnC register.

Comparator Registers

There are four registers for overall comparator operation, two registers, CMPnC and CMPnVOS, for the comparator. As corresponding bits in these registers have identical functions, the following register table applies to the registers.

Register Name	Bit							
	7	6	5	4	3	2	1	0
CMPnC	—	CMPnEN	CnPOL	CMPnO	CNVTn1	CNVTn0	—	—
CMPnVOS	—	CnOFM	CnRSP	CnOF4	CnOF3	CnOF2	CnOF1	CnOF0

Comparator Register List (n=1)

• CMPnC Register (n=1)

Bit	7	6	5	4	3	2	1	0
Name	—	CMPnEN	CnPOL	CMPnO	CNVtn1	CNVtn0	—	—
R/W	—	R/W	R/W	R	R/W	R/W	—	—
POR	—	0	0	0	0	0	—	—

Bit 7 Unimplemented, read as “0”

Bit 6 **CMPnEN**: Comparator n enable or disable selection bit
 0: Disable
 1: Enable

This bit is used to enable the comparator function. If this bit is cleared to zero, the comparator n will be switched off and no power consumed even if analog voltages are applied to its inputs. When the comparator function is disabled, the comparator n output will be set to zero.

Bit 5 **CnPOL**: Comparator n output polarity selection
 0: Output not inverted
 1: Output inverted

If this bit is cleared to zero, the CMPnO bit will reflect the non-inverted output condition of the comparator. If this bit is set high, the CMPnO bit will be inverted.

Bit 4 **CMPnO**: Comparator n output bit
 CnPOL=0
 0: Cn+<Cn-
 1: Cn+>Cn-
 CnPOL=1
 0: Cn+>Cn-
 1: Cn+<Cn-

This bit is used to store the comparator output bit. The polarity of this bit is determined by the voltages on the comparator inputs and by the condition of the CnPOL bit.

Bit 3~2 **CNVtn1~CNVTn0**: Comparator n response time selection
 00: Response time 0 (max.)
 01: Response time 1
 10: Response time 2
 11: Response time 3 (min.)

These bits are used to select the comparator response time. The detailed response time specifications are listed in the Comparator Electrical Characteristics.

Bit 1~0 Unimplemented, read as “0”

• CMPnVOS Register (n=1)

Bit	7	6	5	4	3	2	1	0
Name	—	CnOFM	CnRSP	CnOF4	CnOF3	CnOF2	CnOF1	CnOF0
R/W	—	R/W	R/W	R/W	R/W	R/W	R/W	R/W
POR	—	0	0	1	0	0	0	0

Bit 7 Unimplemented, read as “0”

Bit 6 **CnOFM**: Comparator n normal operation or input offset calibration mode selection
 0: Normal operation mode
 1: Input offset calibration mode

This bit is used to enable the comparator input offset calibration function. Refer to the “Input Offset Calibration” section for the detailed input offset calibration procedures.

Bit 5 **CnRSP**: Comparator n input offset calibration reference input selection
 0: Cn- is selected as reference input
 1: Cn+ is selected as reference input

Bit 4~0 **CnOF4~CnOF0**: Comparator n input offset calibration value
 0: Normal operation mode
 1: Input offset calibration mode

This 5-bit field is used to perform the comparator input offset calibration operation and the value after the input offset calibration can be restored into this bit field. Refer to the “Input Offset Calibration” section for more detailed information.

Input Offset Calibration

To operate in the input offset calibration mode, the comparator input pins to be used should first be selected by properly configuring the corresponding pin-shared function selection bits followed by setting the CnOFM bit high. The procedure is described in the following.

Step 1. Set CnOFM=1, CnRSP=1 to enable the comparator input offset calibration mode.

Step 2. Set CnOF [4:0]=00000 and read the CMPnO bit.

Step 3. Increase the CnOF [4:0] value by 1 and then read the CMPnO bit.

 If the CMPnO bit state does not changed, then repeat Step 3 until the CMPnO bit state changes.

 If the CMPnO bit state changes, record the CnOF field value as V_{CnOS1} and then go to Step 4.

Step 4. Set CnOF [4:0]=11111 and read the CMPnO bit.

Step 5. Decrease the CnOF [4:0] value by 1 and then read the CMPnO bit.

 If the CMPnO bit state does not changed, then repeat Step 5 until the CMPnO bit state changes.

 If the CMPnO bit state changes, record the CnOF field value as V_{CnOS2} and then go to Step 6.

Step 6. Restore the comparator input offset calibration value V_{CnOS} into the CnOF [4:0] bit field. The offset calibration procedure is now finished.

 Where $V_{CnOS}=(V_{CnOS1}+V_{CnOS2})/2$

Comparator Interrupt

The comparator possesses its own interrupt function. When the comparator output bit changes state, its relevant interrupt flag will be set, and if the corresponding interrupt enable bit is set, then a jump to its relevant interrupt vector will be executed. Note that it is the changing state of the CMPnO bit and not the output pin which generates an interrupt. If the microcontroller is in the SLEEP or IDLE Mode and the Comparator is enabled, then if the external input lines cause the Comparator output to change state, the resulting generated interrupt flag will also generate a wake-up. If it is required to disable a wake-up from occurring, then the interrupt flag should be first set high before entering the SLEEP or IDLE Mode.

Programming Considerations

If the comparator is enabled, it will remain active when the microcontroller enters the SLEEP or IDLE Mode, however as it will consume a certain amount of power, the user may wish to consider disabling it before the SLEEP or IDLE Mode is entered.

16-bit Multiplication Division Unit – MDU

The device has a 16-bit Multiplication Division Unit, MDU, which integrates a 16-bit unsigned multiplier and a 32-bit/16-bit divider. The MDU, in replacing the software multiplication and division operations, can therefore save large amounts of computing time as well as the Program and Data Memory space. It also reduces the overall microcontroller loading and results in the overall system performance improvements.

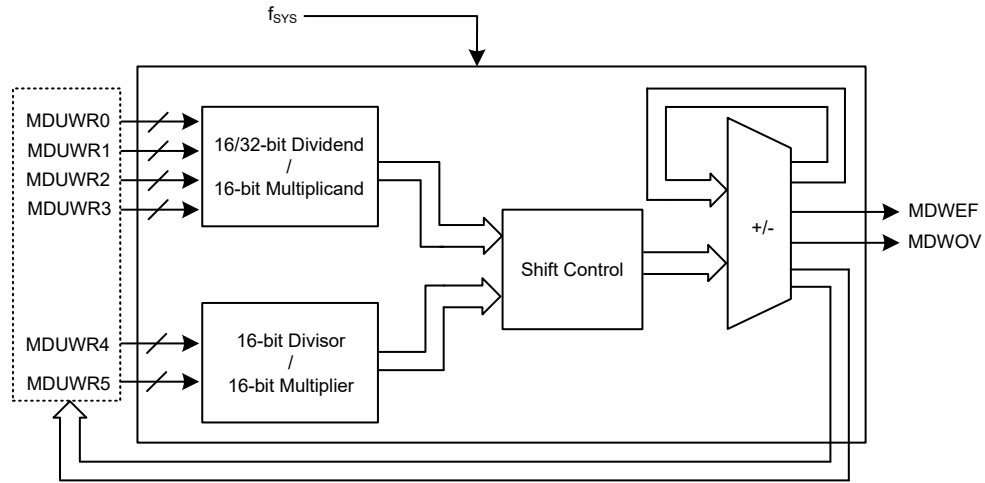

16-Bit MDU Block Diagram

MDU Registers

The multiplication and division operations are implemented in a specific way, a specific write access sequence of a series of MDU data registers. The status register, MDUWCTRL, provides the indications for the MDU operation. The data register each is used to store the data regarded as the different operand corresponding to different MDU operations.

Register Name	Bit							
	7	6	5	4	3	2	1	0
MDUWR0	D7	D6	D5	D4	D3	D2	D1	D0
MDUWR1	D7	D6	D5	D4	D3	D2	D1	D0
MDUWR2	D7	D6	D5	D4	D3	D2	D1	D0
MDUWR3	D7	D6	D5	D4	D3	D2	D1	D0
MDUWR4	D7	D6	D5	D4	D3	D2	D1	D0
MDUWR5	D7	D6	D5	D4	D3	D2	D1	D0
MDUWCTRL	MDWEF	MDWOV	—	—	—	—	—	—

MDU Register List

• **MDUWRn Register (n=0~5)**

Bit	7	6	5	4	3	2	1	0
Name	D7	D6	D5	D4	D3	D2	D1	D0
R/W	R/W	R/W	R/W	R/W	R/W	R/W	R/W	R/W
POR	x	x	x	x	x	x	x	x

“x”: Unknown

Bit 7~0 **D7~D0**: 16-bit MDU data register n

• **MDUWCTRL Register**

Bit	7	6	5	4	3	2	1	0
Name	MDWEF	MDWOV	—	—	—	—	—	—
R/W	R	R	—	—	—	—	—	—
POR	0	0	—	—	—	—	—	—

Bit 7 **MDWEF**: 16-bit MDU error flag
 0: Normal
 1: Abnormal

This bit will be set to 1 if the data register MDUWRn is written or read as the MDU operation is executing. This bit should be cleared to 0 by reading the MDUWCTRL register if it is equal to 1 and the MDU operation is completed.

Bit 6 **MDWOV**: 16-bit MDU overflow flag
 0: No overflow occurs
 1: Multiplication product > FFFFH or Divisor=0

When an operation is completed, this bit will be updated by hardware to a new value corresponding to the current operation situation.

Bit 5~0 Unimplemented, read as “0”

MDU Operation

For this MDU the multiplication or division operation is carried out in a specific way and is determined by the write access sequence of the six MDU data registers, MDUWR0~MDUWR5. The low byte data, regardless of the dividend, multiplicand, divisor or multiplier, must first be written into the corresponding MDU data register followed by the high byte data. All MDU operations will be executed after the MDUWR5 register is write-accessed together with the correct specific write access sequence of the MDUWRn. Note that it is not necessary to consecutively write data into the MDU data registers but must be in a correct write access sequence. Therefore, a non-write MDUWRn instruction or an interrupt, etc., can be inserted into the correct write access sequence without destroying the write operation. The relationship between the write access sequence and the MDU operation is shown in the following.

- 32-bit/16-bit division operation: Write data sequentially into the six MDU data registers from MDUWR0 to MDUWR5.
- 16-bit/16-bit division operation: Write data sequentially into the specific four MDU data registers in a sequence of MDUWR0, MDUWR1, MDUWR4 and MDUWR5 with no write access to MDUWR2 and MDUWR3.
- 16-bit×16-bit multiplication operation: Write data sequentially into the specific four MDU data register in a sequence of MDUWR0, MDUWR4, MDUWR1 and MDUWR5 with no write access to MDUWR2 and MDUWR3.

After the specific write access sequence is determined, the MDU will start to perform the corresponding operation. The calculation time necessary for these MDU operations are different. During the calculation time any read/write access to the six MDU data registers is forbidden. After

the completion of each operation, it is necessary to check the operation status in the MDUWCTRL register to make sure that whether the operation is correct or not. Then the operation result can be read out from the corresponding MDU data registers in a specific read access sequence if the operation is correctly finished. The necessary calculation time for different MDU operations is listed in the following.

- 32-bit/16-bit division operation: $17 \times t_{SYS}$.
- 16-bit/16-bit division operation: $9 \times t_{SYS}$.
- 16-bit \times 16-bit multiplication operation: $11 \times t_{SYS}$.

The operation results will be stored in the corresponding MDU data registers and should be read out from the MDU data registers in a specific read access sequence after the operation is completed. Note that it is not necessary to consecutively read data out from the MDU data registers but must be in a correct read access sequence. Therefore, a non-read MDUWRn instruction or an interrupt, etc., can be inserted into the correct read access sequence without destroying the read operation. The relationship between the operation result read access sequence and the MDU operation is shown in the following.

- 32-bit/16-bit division operation: Read the quotient from MDUWR0 to MDUWR3 and remainder from MDUWR4 and MDUWR5 sequentially.
- 16-bit/16-bit division operation: Read the quotient from MDUWR0 and MDUWR1 and remainder from MDUWR4 and MDUWR5 sequentially.
- 16-bit \times 16-bit multiplication operation: Read the product sequentially from MDUWR0 to MDUWR3.

The overall important points for the MDU read/write access sequence and calculation time are summarized in the following table. Note that the device should not enter the IDLE or SLEEP mode until the MDU operation is totally completed, otherwise the MDU operation will fail.

Operations Items	32-bit / 16-bit Division	16-bit / 16-bit Division	16-bit \times 16-bit Multiplication
Write Sequence First write ↓ ↓ ↓ ↓ Last write	Dividend Byte 0 written to MDUWR0 Dividend Byte 1 written to MDUWR1 Dividend Byte 2 written to MDUWR2 Dividend Byte 3 written to MDUWR3 Divisor Byte 0 written to MDUWR4 Divisor Byte 1 written to MDUWR5	Dividend Byte 0 written to MDUWR0 Dividend Byte 1 written to MDUWR1 Divisor Byte 0 written to MDUWR4 Divisor Byte 1 written to MDUWR5	Multiplicand Byte 0 written to MDUWR0 Multiplier Byte 0 written to MDUWR4 Multiplicand Byte 1 written to MDUWR1 Multiplier Byte 1 written to MDUWR5
Calculation Time	$17 \times t_{SYS}$	$9 \times t_{SYS}$	$11 \times t_{SYS}$
Read Sequence First read ↓ ↓ ↓ ↓ Last read	Quotient Byte 0 read from MDUWR0 Quotient Byte 1 read from MDUWR1 Quotient Byte 2 read from MDUWR2 Quotient Byte 3 read from MDUWR3 Remainder Byte 0 read from MDUWR4 Remainder Byte 1 read from MDUWR5	Quotient Byte 0 read from MDUWR0 Quotient Byte 1 read from MDUWR1 Remainder Byte 0 read from MDUWR4 Remainder Byte 1 read from MDUWR5	Product Byte 0 read from MDUWR0 Product Byte 1 read from MDUWR1 Product Byte 2 read from MDUWR2 Product Byte 3 read from MDUWR3

MDU Operations Summary

Cyclic Redundancy Check – CRC

The Cyclic Redundancy Check, CRC, calculation unit is an error detection technique test algorithm and uses to verify data transmission or storage data correctness. A CRC calculation takes a data stream or a block of data as input and generates a 16-bit output remainder. Ordinarily, a data stream is suffixed by a CRC code and used as a checksum when being sent or stored. Therefore, the received or restored data stream is calculated by the same generator polynomial as described in the following section.

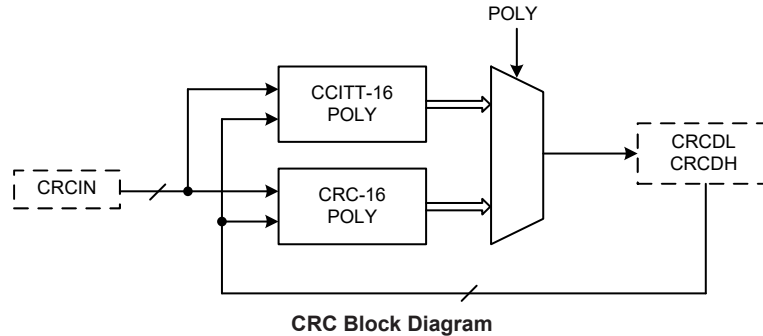

CRC Registers

The CRC generator contains an 8-bit CRC data input register, **CRCIN**, and a CRC checksum register pair, **CRCDH** and **CRCDL**. The **CRCIN** register is used to input new data and the **CRCDH** and **CRCDL** registers are used to hold the previous CRC calculation result. A CRC control register, **CRCCR**, is used to select which CRC generating polynomial is used.

Register Name	Bit							
	7	6	5	4	3	2	1	0
CRCIN	D7	D6	D5	D4	D3	D2	D1	D0
CRCDL	D7	D6	D5	D4	D3	D2	D1	D0
CRCDH	D15	D14	D13	D12	D11	D10	D9	D8
CRCCR	—	—	—	—	—	—	—	POLY

CRC Register List

• CRCIN Register

Bit	7	6	5	4	3	2	1	0
Name	D7	D6	D5	D4	D3	D2	D1	D0
R/W	R/W	R/W	R/W	R/W	R/W	R/W	R/W	R/W
POR	0	0	0	0	0	0	0	0

Bit 7~0 **D7~D0**: CRC input data register

• CRCDL Register

Bit	7	6	5	4	3	2	1	0
Name	D7	D6	D5	D4	D3	D2	D1	D0
R/W	R/W	R/W	R/W	R/W	R/W	R/W	R/W	R/W
POR	0	0	0	0	0	0	0	0

Bit 7~0 **D7~D0**: 16-bit CRC checksum low byte data register

• CRCDH Register

Bit	7	6	5	4	3	2	1	0
Name	D15	D14	D13	D12	D11	D10	D9	D8
R/W	R/W	R/W	R/W	R/W	R/W	R/W	R/W	R/W
POR	0	0	0	0	0	0	0	0

Bit 7~0 **D15~D8:** 16-bit CRC checksum high byte data register

• CRCCR Register

Bit	7	6	5	4	3	2	1	0
Name	—	—	—	—	—	—	—	POLY
R/W	—	—	—	—	—	—	—	R/W
POR	—	—	—	—	—	—	—	0

Bit 7~1 Unimplemented, read as “0”

Bit 0 **POLY:** 16-bit CRC generating polynomial selection

0: CRC-CCITT: $X^{16}+X^{12}+X^5+1$

1: CRC-16: $X^{16}+X^{15}+X^2+1$

CRC Operation

The CRC generator provides the 16-bit CRC result calculation based on the CRC16 and CCITT CRC16 polynomials. In this CRC generator, there are only these two polynomials available for the numeric values calculation. It can not support the 16-bit CRC calculations based on any other polynomials.

The following two expressions can be used for the CRC generating polynomial which is determined using the POLY bit in the CRC control register, CRCCR. The CRC calculation result is called as the CRC checksum, CRCSUM, and stored in the CRC checksum register pair, CRCDH and CRCDL.

- CRC-CCITT: $X^{16}+X^{12}+X^5+1$.
- CRC-16: $X^{16}+X^{15}+X^2+1$.

CRC Computation

Each write operation to the CRCIN register creates a combination of the previous CRC value stored in the CRCDH and CRCDL registers and the new data input. The CRC unit calculates the CRC data register value is based on byte by byte. It will take one MCU instruction cycle to calculate the CRC checksum.

CRC Calculation Procedures:

1. Clear the checksum register pair, CRCDH and CRCDL.
2. Execute an “Exclusive OR” operation with the 8-bit input data byte and the 16-bit CRCSUM high byte. The result is called the temporary CRCSUM.
3. Shift the temporary CRCSUM value left by one bit and move a “0” into the LSB.
4. Check the shifted temporary CRCSUM value after procedure 3.

If the MSB is 0, then this shifted temporary CRCSUM will be considered as a new temporary CRCSUM.

Otherwise, execute an “Exclusive OR” operation with the shifted temporary CRCSUM in procedure 3 and a data “8005H”. Then the operation result will be regarded as the new temporary CRCSUM.

Note that the data to be perform an “Exclusive OR” operation is “8005H” for the CRC-16 polynomial while for the CRC-CCITT polynomial the data is “1021H”.

5. Repeat the procedure 3 ~ procedure 4 until all bits of the input data byte are completely calculated.
6. Repeat the procedure 2 ~ procedure 5 until all of the input data bytes are completely calculated.
 Then, the latest calculated result is the final CRC checksum, CRCSUM.

CRC Calculation Examples:

- Write 1 byte input data into the CRCIN register and the corresponding CRC checksum are individually calculated as the following table shown.

CRC Data Input CRC Polynomial	00H	01H	02H	03H	04H	05H	06H	07H
CRC-CCITT ($X^{16}+X^{12}+X^5+1$)	0000H	1021H	2042H	3063H	4084H	50A5H	60C6H	70E7H
CRC-16 ($X^{16}+X^{15}+X^2+1$)	0000H	8005H	800FH	000AH	801BH	001EH	0014H	8011H

Note: The initial value of the CRC checksum register pair, CRCDH and CRCDL, is zero before each CRC input data is written into the CRCIN register.

- Write 4 bytes input data into the CRCIN register sequentially and the CRC checksum are sequentially listed in the following table.

CRC Data Input CRC Polynomial	CRCIN=78H→56H→34H→12H
CRC-CCITT ($X^{16}+X^{12}+X^5+1$)	(CRCDH, CRCDL)=FF9FH→BBC3H→A367H→D0FAH
CRC-16 ($X^{16}+X^{15}+X^2+1$)	(CRCDH, CRCDL)=0110h→91F1h→F2DEh→5C43h

Note: The initial value of the CRC checksum register pair, CRCDH and CRCDL, is zero before the sequential CRC data input operation.

Program Memory CRC Checksum Calculation Example:

1. Clear the checksum register pair, CRCDH and CRCDL.
2. Select the CRC-CCITT or CRC-16 polynomial as the generating polynomial using the POLY bit in the CRCCR register.
3. Execute the table read instruction to read the program memory data value.
4. Write the table data low byte into the CRCIN register and execute the CRC calculation with the current CRCSUM value. Then a new CRCSUM result will be obtained and stored in the CRC checksum register pair, CRCDH and CRCDL.
5. Write the table data high byte into the CRCIN register and execute the CRC calculation with the current CRCSUM value. Then a new CRCSUM result will be obtained and stored in the CRC checksum register pair, CRCDH and CRCDL.
6. Repeat the procedure 3 ~ procedure 5 to read the next program memory data value and execute the CRC calculation until all program memory data are read followed by the sequential CRC calculation. Then the value in the CRC checksum register pair is the final CRC calculation result.

Software Controlled LCD Driver

The device has the capability of driving external LCD panels. The common pins for LCD driving, SCOM0~SCOM3, are pin-shared with certain functions on the I/O ports. The LCD signals (COM) are generated using the application program.

LCD Operation

An external LCD panel can be driven using the device by configuring the I/O pins as common pins. The LCD driver function is controlled using the SCOMC registers which in addition to controlling the overall on/off function also R-type controls the bias current on the SCOMn pins. This enables the LCD COM to generate the necessary $V_{DD}/2$ voltage levels for LCD 1/2 bias operation.

The SCOMEN bit in the SCOMC register is the overall master control for the LCD driver. The LCD SCOMn pin is selected to be used for LCD driving by the corresponding pin-shared function selection bits. Note that the port control register does not need to first setup the pins as outputs to enable the LCD driver operation.

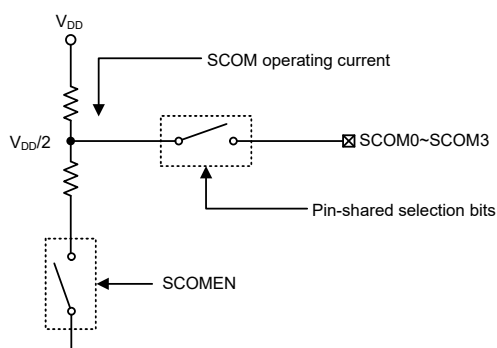

Software Controlled LCD Driver Structure

LCD Control Registers

The LCD COM driver enables a range of selections to be provided to suit the requirement of the LCD panel which is being used. The bias resistor choice is implemented using the ISEL1 and ISEL0 bits in the SCOMC register.

• SCOMC Register

Bit	7	6	5	4	3	2	1	0
Name	—	ISEL1	ISEL0	SCOMEN	—	—	—	—
R/W	—	R/W	R/W	R/W	—	—	—	—
POR	—	0	0	0	—	—	—	—

Bit 7 Unimplemented, read as “0”

Bit 6~5 **ISEL1~ISEL0**: Select resistor for R type LCD bias current (@ $V_{DD}=5V$)

00: $2 \times 100k\Omega$ (1/2 Bias), $I_{BIAS}=25\mu A$

01: $2 \times 50k\Omega$ (1/2 Bias), $I_{BIAS}=50\mu A$

10: $2 \times 25k\Omega$ (1/2 Bias), $I_{BIAS}=100\mu A$

11: $2 \times 12.5k\Omega$ (1/2 Bias), $I_{BIAS}=200\mu A$

Bit 4 **SCOMEN**: Software controlled LCD drive function enable control

0: Disable

1: Enable

When the SCOMEN bit is set, it will turn on the DC path of resistor to generate 1/2 V_{DD} bias voltage.

Bit 3~0 Unimplemented, read as “0”

Interrupts

Interrupts are an important part of any microcontroller system. When an external event or an internal function such as a Timer Module or an A/D converter requires microcontroller attention, their corresponding interrupt will enforce a temporary suspension of the main program allowing the microcontroller to direct attention to their respective needs. The device contains several external interrupt and internal interrupt functions. The external interrupts are generated by the action of the external INT0~INT3 pins, while the internal interrupts are generated by various internal functions such as the Timer Modules, Time Bases, Low Voltage Detector (LVD), EEPROM, SIM and the A/D converter.

Interrupt Registers

Overall interrupt control, which basically means the setting of request flags when certain microcontroller conditions occur and the setting of interrupt enable bits by the application program, is controlled by a series of registers, located in the Special Purpose Data Memory. The registers fall into three categories. The first is the INTC0~INTC3 registers which setup the primary interrupts, the second is the MFI0~MFI5 registers which setup the Multi-function interrupts. Finally there is an INTEG register to setup the external interrupts trigger edge type.

Each register contains a number of enable bits to enable or disable individual registers as well as interrupt flags to indicate the presence of an interrupt request. The naming convention of these follows a specific pattern. First is listed an abbreviated interrupt type, then the (optional) number of that interrupt followed by either an “E” for enable/disable bit or “F” for request flag.

Function	Enable Bit	Request Flag	Notes
Global	EMI	—	—
INTn Pin	INTnE	INTnF	n=0~3
A/D Converter	ADE	ADF	—
Multi-function	MFnE	MFnF	n=0~5
Time Base	TBnE	TBnF	n=0~1
LVD	LVE	LVF	—
EEPROM	DEE	DEF	—
SIM	SIME	SIMF	—
STM	STMnPE	STMnPF	n=0~1
	STMnAE	STMnAF	
PTM	PTMnPE	PTMnPF	n=0~3
	PTMnAE	PTMnAF	
UART	URnE	URnF	n=0~1
Comparator	CPnE	CPnF	n=1

Interrupt Register Bit Naming Conventions

Register Name	Bit							
	7	6	5	4	3	2	1	0
INTEG	INT3S1	INT3S0	INT2S1	INT2S0	INT1S1	INT1S0	INT0S1	INT0S0
INTC0	—	D6	INT1F	INT0F	D3	INT1E	INT0E	EMI
INTC1	ADF	MF1F	MF0F	CP1F	ADE	MF1E	MF0E	CP1E
INTC2	MF3F	TB1F	TB0F	MF2F	MF3E	TB1E	TB0E	MF2E
INTC3	MF5F	MF4F	INT3F	INT2F	MF5E	MF4E	INT3E	INT2E
MF10	STM0AF	STM0PF	PTM0AF	PTM0PF	STM0AE	STM0PE	PTM0AE	PTM0PE
MF11	STM1AF	STM1PF	PTM1AF	PTM1PF	STM1AE	STM1PE	PTM1AE	PTM1PE
MF12	—	—	PTM2AF	PTM2PF	—	—	PTM2AE	PTM2PE
MF13	SIMF	D6	DEF	LVF	SIME	D2	DEE	LVE
MF14	D7	D6	PTM3AF	PTM3PF	D3	D2	PTM3AE	PTM3PE
MF15	—	—	UR1F	UR0F	—	—	UR1E	UR0E

Interrupt Register List
• INTEG Register

Bit	7	6	5	4	3	2	1	0
Name	INT3S1	INT3S0	INT2S1	INT2S0	INT1S1	INT1S0	INT0S1	INT0S0
R/W	R/W	R/W	R/W	R/W	R/W	R/W	R/W	R/W
POR	0	0	0	0	0	0	0	0

Bit 7~6 **INT3S1~INT3S0**: Interrupt edge control for INT3 pin
00: Disable
01: Rising edge
10: Falling edge
11: Rising and falling edges

Bit 5~4 **INT2S1~INT2S0**: Interrupt edge control for INT2 pin
00: Disable
01: Rising edge
10: Falling edge
11: Rising and falling edges

Bit 3~2 **INT1S1~INT1S0**: Interrupt edge control for INT1 pin
00: Disable
01: Rising edge
10: Falling edge
11: Rising and falling edges

Bit 1~0 **INT0S1~INT0S0**: Interrupt edge control for INT0 pin
00: Disable
01: Rising edge
10: Falling edge
11: Rising and falling edges

• **INTC0 Register**

Bit	7	6	5	4	3	2	1	0
Name	—	D6	INT1F	INT0F	D3	INT1E	INT0E	EMI
R/W	—	R/W	R/W	R/W	R/W	R/W	R/W	R/W
POR	—	0	0	0	0	0	0	0

- Bit 7 Unimplemented, read as “0”
- Bit 6 **D6**: The bit should be kept unchanged after power on
- Bit 5 **INT1F**: External interrupt 1 request flag
 0: No request
 1: Interrupt request
- Bit 4 **INT0F**: External interrupt 0 request flag
 0: No request
 1: Interrupt request
- Bit 3 **D3**: The bit should be kept unchanged after power on
- Bit 2 **INT1E**: External interrupt 1 control
 0: Disable
 1: Enable
- Bit 1 **INT0E**: External interrupt 0 control
 0: Disable
 1: Enable
- Bit 0 **EMI**: Global interrupt control
 0: Disable
 1: Enable

• **INTC1 Register**

Bit	7	6	5	4	3	2	1	0
Name	ADF	MF1F	MF0F	CP1F	ADE	MF1E	MF0E	CP1E
R/W	R/W	R/W	R/W	R/W	R/W	R/W	R/W	R/W
POR	0	0	0	0	0	0	0	0

- Bit 7 **ADF**: A/D converter interrupt request flag
 0: No request
 1: Interrupt request
- Bit 6 **MF1F**: Multi-function 1 interrupt request flag
 0: No request
 1: Interrupt request
- Bit 5 **MF0F**: Multi-function 0 interrupt request flag
 0: No request
 1: Interrupt request
- Bit 4 **CP1F**: Comparator 1 interrupt request flag
 0: No request
 1: Interrupt request
- Bit 3 **ADE**: A/D converter interrupt control
 0: Disable
 1: Enable
- Bit 2 **MF1E**: Multi-function 1 interrupt control
 0: Disable
 1: Enable
- Bit 1 **MF0E**: Multi-function 0 interrupt control
 0: Disable
 1: Enable

Bit 0 **CP1E**: Comparator 1 interrupt control
0: Disable
1: Enable

• **INTC2 Register**

Bit	7	6	5	4	3	2	1	0
Name	MF3F	TB1F	TB0F	MF2F	MF3E	TB1E	TB0E	MF2E
R/W	R/W	R/W	R/W	R/W	R/W	R/W	R/W	R/W
POR	0	0	0	0	0	0	0	0

Bit 7 **MF3F**: Multi-function interrupt 3 request flag
0: No request
1: Interrupt request

Bit 6 **TB1F**: Time Base 1 interrupt request flag
0: No request
1: Interrupt request

Bit 5 **TB0F**: Time Base 0 interrupt request flag
0: No request
1: Interrupt request

Bit 4 **MF2F**: Multi-function interrupt 2 request flag
0: No request
1: Interrupt request

Bit 3 **MF3E**: Multi-function interrupt 3 control
0: Disable
1: Enable

Bit 2 **TB1E**: Time Base 1 interrupt control
0: Disable
1: Enable

Bit 1 **TB0E**: Time Base 0 interrupt control
0: Disable
1: Enable

Bit 0 **MF2E**: Multi-function interrupt 2 control
0: Disable
1: Enable

• **INTC3 Register**

Bit	7	6	5	4	3	2	1	0
Name	MF5F	MF4F	INT3F	INT2F	MF5E	MF4E	INT3E	INT2E
R/W	R/W	R/W	R/W	R/W	R/W	R/W	R/W	R/W
POR	0	0	0	0	0	0	0	0

Bit 7 **MF5F**: Multi-function interrupt 5 request flag
0: No request
1: Interrupt request

Bit 6 **MF4F**: Multi-function interrupt 4 request flag
0: No request
1: Interrupt request

Bit 5 **INT3F**: INT3 Interrupt Request Flag
0: No request
1: Interrupt request

Bit 4 **INT2F**: INT2 Interrupt Request Flag
0: No request
1: Interrupt request

- Bit 3 **MF5E**: Multi-function interrupt 5 control
 0: Disable
 1: Enable
- Bit 2 **MF4E**: Multi-function interrupt 4 control
 0: Disable
 1: Enable
- Bit 1 **INT3E**: INT3 interrupt control
 0: Disable
 1: Enable
- Bit 0 **INT2E**: INT2 interrupt control
 0: Disable
 1: Enable

• **MFI0 Register**

Bit	7	6	5	4	3	2	1	0
Name	STM0AF	STM0PF	PTM0AF	PTM0PF	STM0AE	STM0PE	PTM0AE	PTM0PE
R/W	R/W	R/W	R/W	R/W	R/W	R/W	R/W	R/W
POR	0	0	0	0	0	0	0	0

- Bit 7 **STM0AF**: STM0 CCRA comparator interrupt request flag
 0: No request
 1: Interrupt request
- Bit 6 **STM0PF**: STM0 CCRP comparator interrupt request flag
 0: No request
 1: Interrupt request
- Bit 5 **PTM0AF**: PTM0 CCRA comparator interrupt request flag
 0: No request
 1: Interrupt request
- Bit 4 **PTM0PF**: PTM0 CCRP comparator interrupt request flag
 0: No request
 1: Interrupt request
- Bit 3 **STM0AE**: STM0 CCRA comparator interrupt control
 0: Disable
 1: Enable
- Bit 2 **STM0PE**: STM0 CCRP comparator interrupt control
 0: Disable
 1: Enable
- Bit 1 **PTM0AE**: PTM0 CCRA comparator interrupt control
 0: Disable
 1: Enable
- Bit 0 **PTM0PE**: PTM0 CCRP comparator interrupt control
 0: Disable
 1: Enable

• MF1 Register

Bit	7	6	5	4	3	2	1	0
Name	STM1AF	STM1PF	PTM1AF	PTM1PF	STM1AE	STM1PE	PTM1AE	PTM1PE
R/W	R/W	R/W	R/W	R/W	R/W	R/W	R/W	R/W
POR	0	0	0	0	0	0	0	0

- Bit 7 **STM1AF**: STM1 CCRA comparator interrupt request flag
0: No request
1: Interrupt request
- Bit 6 **STM1PF**: STM1 CCRP comparator interrupt request flag
0: No request
1: Interrupt request
- Bit 5 **PTM1AF**: PTM1 CCRA comparator interrupt request flag
0: No request
1: Interrupt request
- Bit 4 **PTM1PF**: PTM1 CCRP comparator interrupt request flag
0: No request
1: Interrupt request
- Bit 3 **STM1AE**: STM1 CCRA comparator interrupt control
0: Disable
1: Enable
- Bit 2 **STM1PE**: STM1 CCRP comparator interrupt control
0: Disable
1: Enable
- Bit 1 **PTM1AE**: PTM1 CCRA comparator interrupt control
0: Disable
1: Enable
- Bit 0 **PTM1PE**: PTM1 CCRP comparator interrupt control
0: Disable
1: Enable

• MF12 Register

Bit	7	6	5	4	3	2	1	0
Name	—	—	PTM2AF	PTM2PF	—	—	PTM2AE	PTM2PE
R/W	—	—	R/W	R/W	—	—	R/W	R/W
POR	—	—	0	0	—	—	0	0

- Bit 7~6 Unimplemented, read as “0”
- Bit 5 **PTM2AF**: PTM2 CCRA comparator interrupt request flag
0: No request
1: Interrupt request
- Bit 4 **PTM2PF**: PTM2 CCRP comparator interrupt request flag
0: No request
1: Interrupt request
- Bit 3~2 Unimplemented, read as “0”
- Bit 1 **PTM2AE**: PTM2 CCRA comparator interrupt control
0: Disable
1: Enable
- Bit 0 **PTM2PE**: PTM2 CCRP comparator interrupt control
0: Disable
1: Enable

• **MFI3 Register**

Bit	7	6	5	4	3	2	1	0
Name	SIMF	D6	DEF	LVF	SIME	D2	DEE	LVE
R/W	R/W	R/W	R/W	R/W	R/W	R/W	R/W	R/W
POR	0	0	0	0	0	0	0	0

- Bit 7 **SIMF**: SIM interrupt request flag
 0: No request
 1: Interrupt request
- Bit 6 **D6**: The bit should be kept unchanged after power on
- Bit 5 **DEF**: Data EEPROM interrupt request flag
 0: No request
 1: Interrupt request
- Bit 4 **LVF**: LVD interrupt request flag
 0: No request
 1: Interrupt request
- Bit 3 **SIME**: SIM interrupt control
 0: Disable
 1: Enable
- Bit 2 **D2**: The bit should be kept unchanged after power on
- Bit 1 **DEE**: Data EEPROM interrupt control
 0: Disable
 1: Enable
- Bit 0 **LVE**: LVD interrupt control
 0: Disable
 1: Enable

• **MFI4 Register**

Bit	7	6	5	4	3	2	1	0
Name	D7	D6	PTM3AF	PTM3PF	D3	D2	PTM3AE	PTM3PE
R/W	R/W	R/W	R/W	R/W	R/W	R/W	R/W	R/W
POR	0	0	0	0	0	0	0	0

- Bit 7~6 **D7~D6**: These bits should be kept unchanged after power on
- Bit 5 **PTM3AF**: PTM3 CCRA comparator interrupt request flag
 0: No request
 1: Interrupt request
- Bit 4 **PTM3PF**: PTM3 CCRP comparator interrupt request flag
 0: No request
 1: Interrupt request
- Bit 3~2 **D3~D2**: These bits should be kept unchanged after power on
- Bit 1 **PTM3AE**: PTM3 CCRA comparator interrupt control
 0: Disable
 1: Enable
- Bit 0 **PTM3PE**: PTM3 CCRP comparator interrupt control
 0: Disable
 1: Enable

• **MF15 Register**

Bit	7	6	5	4	3	2	1	0
Name	—	—	UR1F	UR0F	—	—	UR1E	UR0E
R/W	—	—	R/W	R/W	—	—	R/W	R/W
POR	—	—	0	0	—	—	0	0

- Bit 7~6 Unimplemented, read as “0”
- Bit 5 **UR1F**: UART1 interrupt request flag
0: No request
1: Interrupt request
- Bit 4 **UR0F**: UART0 interrupt request flag
0: No request
1: Interrupt request
- Bit 3~2 Unimplemented, read as “0”
- Bit 1 **UR1E**: UART1 interrupt control
0: Disable
1: Enable
- Bit 0 **UR0E**: UART0 interrupt control
0: Disable
1: Enable

Interrupt Operation

When the conditions for an interrupt event occur, such as a TM Comparator P, Comparator A match or A/D conversion completion etc., the relevant interrupt request flag will be set. Whether the request flag actually generates a program jump to the relevant interrupt vector is determined by the condition of the interrupt enable bit. If the enable bit is set high then the program will jump to its relevant vector; if the enable bit is zero then although the interrupt request flag is set an actual interrupt will not be generated and the program will not jump to the relevant interrupt vector. The global interrupt enable bit, if cleared to zero, will disable all interrupts.

When an interrupt is generated, the Program Counter, which stores the address of the next instruction to be executed, will be transferred onto the stack. The Program Counter will then be loaded with a new address which will be the value of the corresponding interrupt vector. The microcontroller will then fetch its next instruction from this interrupt vector. The instruction at this vector will usually be a “JMP” which will jump to another section of program which is known as the interrupt service routine. Here is located the code to control the appropriate interrupt. The interrupt service routine must be terminated with an “RETI”, which retrieves the original Program Counter address from the stack and allows the microcontroller to continue with normal execution at the point where the interrupt occurred.

The various interrupt enable bits, together with their associated request flags, are shown in the accompanying diagrams with their order of priority. Some interrupt sources have their own individual vector while others share the same multi-function interrupt vector. Once an interrupt subroutine is serviced, all the other interrupts will be blocked, as the global interrupt enable bit, EMI bit will be cleared automatically. This will prevent any further interrupt nesting from occurring. However, if other interrupt requests occur during this interval, although the interrupt will not be immediately serviced, the request flag will still be recorded.

If an interrupt requires immediate servicing while the program is already in another interrupt service routine, the EMI bit should be set after entering the routine, to allow interrupt nesting. If the stack is full, the interrupt request will not be acknowledged, even if the related interrupt is enabled, until the Stack Pointer is decremented. If immediate service is desired, the stack must be prevented from

becoming full. In case of simultaneous requests, the accompanying diagram shows the priority that is applied. All of the interrupt request flags when set will wake-up the device if it is in SLEEP or IDLE Mode, however to prevent a wake-up from occurring the corresponding flag should be set before the device is in SLEEP or IDLE Mode.

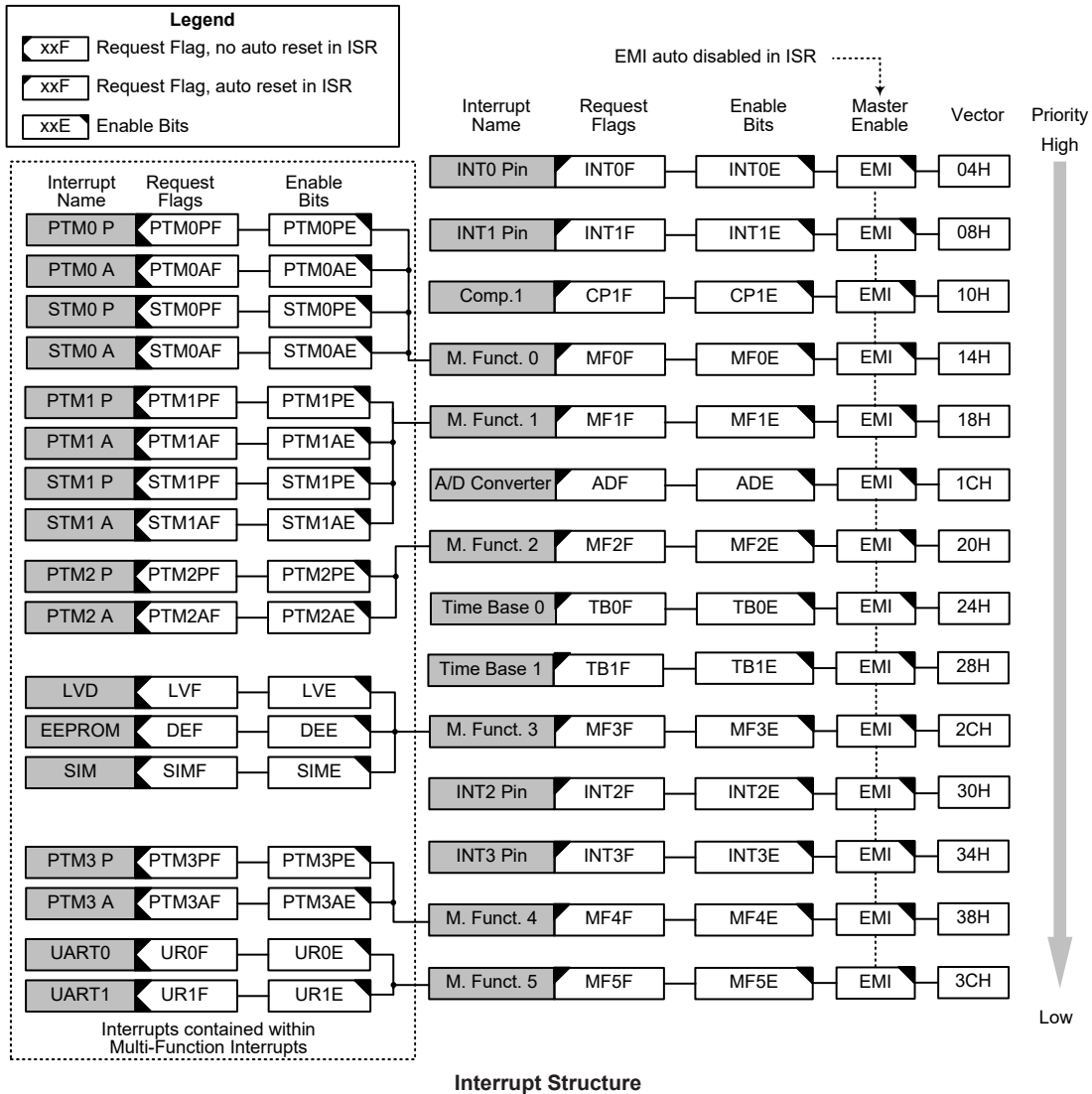

External Interrupts

The external interrupts are controlled by signal transitions on the pins INT0~INT3. An external interrupt request will take place when the external interrupt request flags, INT0F~INT3F, are set, which will occur when a transition, whose type is chosen by the edge select bits, appears on the external interrupt pins. To allow the program to branch to its respective interrupt vector address, the global interrupt enable bit, EMI, and respective external interrupt enable bit, INT0E~INT3E, must first be set. Additionally the correct interrupt edge type must be selected using the INTEG register to enable the external interrupt function and to choose the trigger edge type. As the external interrupt pins are pin-shared with I/O pins, they can only be configured as external interrupt pins if their external interrupt enable bit in the corresponding interrupt register has been set and the external interrupt pin is selected by the corresponding pin-shared function selection bits. The pin must also

be setup as an input by setting the corresponding bit in the port control register.

When the interrupt is enabled, the stack is not full and the correct transition type appears on the external interrupt pin, a subroutine call to the external interrupt vector, will take place. When the interrupt is serviced, the external interrupt request flags, INT0F~INT3F, will be automatically reset and the EMI bit will be automatically cleared to disable other interrupts. Note that any pull-high resistor selections on the external interrupt pins will remain valid even if the pin is used as an external interrupt input. The INTEG register is used to select the type of active edge that will trigger the external interrupt. A choice of either rising or falling or both edge types can be chosen to trigger an external interrupt. Note that the INTEG register can also be used to disable the external interrupt function.

Comparator Interrupt

The comparator interrupt is controlled by the internal comparators. A comparator interrupt request will take place when the comparator interrupt request flags, CP1F, is set, a situation that will occur when the comparator output bit changes state. To allow the program to branch to its respective interrupt vector address, the global interrupt enable bit, EMI, and comparator interrupt enable bit, CP1E, must first be set. When the interrupt is enabled, the stack is not full and the comparator inputs generate a comparator output transition, a subroutine call to the comparator interrupt vector, will take place. When the interrupt is serviced, the comparator interrupt request flag will be automatically reset and the EMI bit will also be automatically cleared to disable other interrupts.

A/D Converter Interrupt

The A/D converter interrupt is controlled by the termination of an A/D conversion process. An A/D converter interrupt request will take place when the A/D Converter Interrupt request flag, ADF, is set, which occurs when the A/D conversion process finishes. To allow the program to branch to its respective interrupt vector address, the global interrupt enable bit, EMI, and A/D converter interrupt enable bit, ADE, must first be set. When the interrupt is enabled, the stack is not full and the A/D conversion process has ended, a subroutine call to the A/D converter interrupt vector, will take place. When the interrupt is serviced, the A/D converter interrupt flag, ADF, will be automatically cleared. The EMI bit will also be automatically cleared to disable other interrupts.

Multi-function Interrupts

Within this device there are several multi-function interrupts. Unlike the other independent interrupts, these interrupts have no independent source, but rather are formed from other existing interrupt sources, namely the TM interrupts, LVD interrupt, EEPROM erase or write operation interrupt, SIM interface interrupt and UART interface interrupts.

A multi-function interrupt request will take place when any of the multi-function interrupt request flags, MFnF are set. The multi-function interrupt flags will be set when any of their included functions generate an interrupt request flag. When the multi-function interrupt is enabled and the stack is not full, and either one of the interrupts contained within each of multi-function interrupt occurs, a subroutine call to one of the multi-function interrupt vectors will take place. When the interrupt is serviced, the related multi-function request flag will be automatically reset and the EMI bit will be automatically cleared to disable other interrupts.

However, it must be noted that, although the multi-function Interrupt flags will be automatically reset when the interrupt is serviced, the request flags from the original source of the multi-function interrupts will not be automatically reset and must be manually reset by the application program.

Timer Module Interrupts

Each of the Standard and Periodic Type TM has two interrupts. All of the TM interrupts are contained within the Multi-function Interrupts. For all of the TM types there are two interrupt request flags of STMnPF, STMnAF and PTMnPF, PTMnAF, and two enable bits of STMnPE, STMnAE and PTMnPE, PTMnAE. A TM interrupt request will take place when any of the TM request flags are set, a situation which occurs when a TM comparator P or A match situation happens.

To allow the program to branch to its respective interrupt vector address, the global interrupt enable bit, EMI, respective TM interrupt enable bit, and relevant multi-function interrupt enable bit, MFnE, must first be set. When the interrupt is enabled, the stack is not full and a TM comparator match situation occurs, a subroutine call to the relevant multi-function interrupt vector locations, will take place. When the TM interrupt is serviced, the EMI bit will be automatically cleared to disable other interrupts, however only the related MFnF flag will be automatically cleared. As the TM interrupt request flags will not be automatically cleared, they have to be cleared by the application program.

LVD Interrupt

The Low Voltage Detector interrupt is contained within the multi-function interrupt. An LVD interrupt request will take place when the LVD interrupt request flag, LVF, is set, which occurs when the Low Voltage Detector function detects a low power supply voltage. To allow the program to branch to its respective interrupt vector address, the global interrupt enable bit, EMI, Low Voltage interrupt enable bit, LVE, and associated multi-function interrupt enable bit, must first be set. When the interrupt is enabled, the stack is not full and a low voltage condition occurs, a subroutine call to the multi-function interrupt vector, will take place. When the Low Voltage interrupt is serviced, the EMI bit will be automatically cleared to disable other interrupts, however only the multi-function interrupt request flag will be also automatically cleared. As the LVF flag will not be automatically cleared, it has to be cleared by the application program.

EEPROM Interrupt

The EEPROM interrupt is contained within the multi-function interrupt. An EEPROM interrupt request will take place when the EEPROM interrupt request flag, DEF, is set, which occurs when an EEPROM erase/write cycle ends. To allow the program to branch to its respective interrupt vector address, the global interrupt enable bit, EMI, EEPROM interrupt enable bit, DEE, and associated multi-function interrupt enable bit, must first be set. When the interrupt is enabled, the stack is not full and an EEPROM erase/write cycle ends, a subroutine call to the respective EEPROM interrupt vector will take place. When the EEPROM interrupt is serviced, the EMI bit will be automatically cleared to disable other interrupts, however only the multi-function interrupt request flag will be also automatically cleared. As the DEF flag will not be automatically cleared, it has to be cleared by the application program.

SIM Interrupt

The Serial Interface Module Interrupt, as known as the SIM Interrupt, is contained within the Multi-function Interrupt. A SIM Interrupt request will take place when the SIM Interrupt request flag, SIMF, is set, which occurs when a byte of data has been received or transmitted by the SIM interface, an I²C address match occurs or an I²C bus time-out occurs. To allow the program to branch to its respective interrupt vector address, the global interrupt enable bit, EMI, the Serial Interface Interrupt enable bit, SIME, and Multi-function interrupt enable bit must first be set. When the interrupt is enabled, the stack is not full and any of the above described situations occurs, a subroutine call to the respective Multi-function interrupt vector, will take place. When the SIM Interface Interrupt is serviced, the EMI bit will be automatically cleared to disable other interrupts, however only the Multi-function interrupt request flag will be also automatically cleared. As the SIMF flag will not be automatically cleared, it has to be cleared by the application program.

UART Transfer Interrupt

The UART Transfer Interrupt is controlled within the Multi-function interrupt and controlled by several UART transfer conditions. When one of these conditions occurs, an interrupt pulse will be generated to get the attention of the microcontroller. These conditions are a transmitter data register empty, transmitter idle, receiver data available, receiver overrun, address detect and an RXn pin wake-up. To allow the program to branch to its respective interrupt vector address, the global interrupt enable bit, EMI, and UARTn Interrupt enable bit, URnE, and Multi-function interrupt enable bit must first be set. When the interrupt is enabled, the stack is not full and any of the conditions described above occurs, a subroutine call to the corresponding Multi-function Interrupt vector, will take place. When the UART interrupt is serviced, the EMI bit will be automatically cleared to disable other interrupts. However, only the Multi-function interrupt request flag will be automatically cleared. As the UART Interrupt flag, URnF, will not be automatically cleared, it has to be cleared by the application program. However, the UnSR register flags will only be cleared when certain actions are taken by the UART, the details of which are given in the UART section.

Time Base Interrupts

The function of the Time Base interrupts is to provide regular time signal in the form of an internal interrupt. They are controlled by the overflow signals from their respective timer functions. When these happens their respective interrupt request flags, TBOF or TB1F will be set. To allow the program to branch to their respective interrupt vector addresses, the global interrupt enable bit, EMI and Time Base enable bits, TBOE or TB1E, must first be set. When the interrupt is enabled, the stack is not full and the Time Base overflows, a subroutine call to their respective vector locations will take place. When the interrupt is serviced, the respective interrupt request flag, TBOF or TB1F, will be automatically reset and the EMI bit will be cleared to disable other interrupts.

The purpose of the Time Base interrupt is to provide an interrupt signal at fixed time periods. Its clock source, f_{PSC0} or f_{PSC1} , originates from the internal clock source f_{SYS} , $f_{SYS}/4$ or f_{SUB} and then passes through a divider, the division ratio of which is selected by programming the appropriate bits in the TB0C and TB1C registers to obtain longer interrupt periods whose value ranges. The clock source which in turn controls the Time Base interrupt period is selected using the CLKSEL0[1:0] and CLKSEL1[1:0] bits in the PSC0R and PSC1R register.

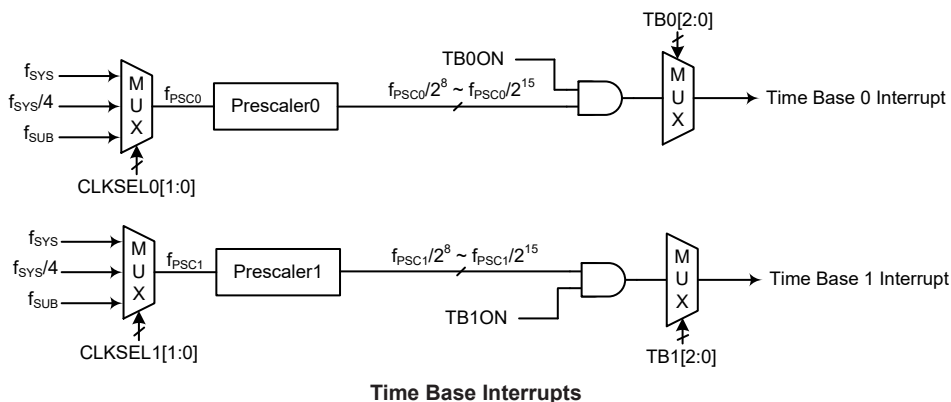

• **PSCnR Register (n=0~1)**

Bit	7	6	5	4	3	2	1	0
Name	—	—	—	—	—	—	CLKSELn1	CLKSELn0
R/W	—	—	—	—	—	—	R/W	R/W
POR	—	—	—	—	—	—	0	0

Bit 7~2 Unimplemented, read as “0”

Bit 1~0 **CLKSELn1~CLKSELn0**: Prescaler clock source f_{PSCn} selection
 00: f_{SYS}
 01: $f_{SYS}/4$
 1x: f_{SUB}

• **TB0C Register**

Bit	7	6	5	4	3	2	1	0
Name	TB0ON	—	—	—	—	TB02	TB01	TB00
R/W	R/W	—	—	—	—	R/W	R/W	R/W
POR	0	—	—	—	—	0	0	0

Bit 7 **TB0ON**: Time Base 0 control
 0: Disable
 1: Enable

Bit 6~3 Unimplemented, read as “0”

Bit 2~0 **TB02~TB00**: Select Time Base 0 time-out period
 000: $2^8/f_{PSC0}$
 001: $2^9/f_{PSC0}$
 010: $2^{10}/f_{PSC0}$
 011: $2^{11}/f_{PSC0}$
 100: $2^{12}/f_{PSC0}$
 101: $2^{13}/f_{PSC0}$
 110: $2^{14}/f_{PSC0}$
 111: $2^{15}/f_{PSC0}$

• **TB1C Register**

Bit	7	6	5	4	3	2	1	0
Name	TB1ON	—	—	—	—	TB12	TB11	TB10
R/W	R/W	—	—	—	—	R/W	R/W	R/W
POR	0	—	—	—	—	0	0	0

Bit 7 **TB1ON**: Time Base 1 control
 0: Disable
 1: Enable

Bit 6~3 Unimplemented, read as “0”

Bit 2~0 **TB12~TB10**: Select Time Base 1 time-out period
 000: $2^8/f_{PSC1}$
 001: $2^9/f_{PSC1}$
 010: $2^{10}/f_{PSC1}$
 011: $2^{11}/f_{PSC1}$
 100: $2^{12}/f_{PSC1}$
 101: $2^{13}/f_{PSC1}$
 110: $2^{14}/f_{PSC1}$
 111: $2^{15}/f_{PSC1}$

Interrupt Wake-up Function

Each of the interrupt functions has the capability of waking up the microcontroller when in the SLEEP or IDLE Mode. A wake-up is generated when an interrupt request flag changes from low to high and is independent of whether the interrupt is enabled or not. Therefore, even though the device is in the SLEEP or IDLE Mode and its system oscillator stopped, situations such as external edge transitions on the external interrupt pins or a low power supply voltage may cause their respective interrupt flag to be set high and consequently generate an interrupt. Care must therefore be taken if spurious wake-up situations are to be avoided. If an interrupt wake-up function is to be disabled then the corresponding interrupt request flag should be set high before the device enters the SLEEP or IDLE Mode. The interrupt enable bits have no effect on the interrupt wake-up function.

Programming Considerations

By disabling the relevant interrupt enable bits, a requested interrupt can be prevented from being serviced, however, once an interrupt request flag is set, it will remain in this condition in the interrupt register until the corresponding interrupt is serviced or until the request flag is cleared by the application program.

Where a certain interrupt is contained within a multi-function interrupt, then when the interrupt service routine is executed, as only the multi-function interrupt request flags, MFnF, will be automatically cleared, the individual request flag for the function needs to be cleared by the application program.

It is recommended that programs do not use the “CALL” instruction within the interrupt service subroutine. Interrupts often occur in an unpredictable manner or need to be serviced immediately. If only one stack is left and the interrupt is not well controlled, the original control sequence will be damaged once a CALL subroutine is executed in the interrupt subroutine.

Every interrupt has the capability of waking up the microcontroller when it is in SLEEP or IDLE Mode, the wake up being generated when the interrupt request flag changes from low to high. If it is required to prevent a certain interrupt from waking up the microcontroller then its respective request flag should be first set high before enter SLEEP or IDLE Mode.

As only the Program Counter is pushed onto the stack, then when the interrupt is serviced, if the contents of the accumulator, status register or other registers are altered by the interrupt service program, their contents should be saved to the memory at the beginning of the interrupt service routine. To return from an interrupt subroutine, either an RET or RETI instruction may be executed. The RETI instruction in addition to executing a return to the main program also automatically sets the EMI bit high to allow further interrupts. The RET instruction however only executes a return to the main program leaving the EMI bit in its present zero state and therefore disabling the execution of further interrupts.

Low Voltage Detector – LVD

The device has a Low Voltage Detector function, also known as LVD. This enabled the device to monitor the power supply voltage, V_{DD} , and provide a warning signal should it fall below a certain level. This function may be especially useful in battery applications where the supply voltage will gradually reduce as the battery ages, as it allows an early warning battery low signal to be generated. The Low Voltage Detector also has the capability of generating an interrupt signal.

LVD Register

The Low Voltage Detector function is controlled using a single register with the name LVDC. Three bits in this register, VLVD2~VLVD0, are used to select one of eight fixed voltages below which a low voltage condition will be determined. A low voltage condition is indicated when the LVDO bit is set. If the LVDO bit is low, this indicates that the V_{DD} pin input voltage is above the preset low voltage value. The LVDEN bit is used to control the overall on/off function of the low voltage detector. Setting the bit high will enable the low voltage detector. Clearing the bit to zero will switch off the internal low voltage detector circuits. As the low voltage detector will consume a certain amount of power, it may be desirable to switch off the circuit when not in use, an important consideration in power sensitive battery powered applications.

• LVDC Register

Bit	7	6	5	4	3	2	1	0
Name	—	—	LVDO	LVDEN	—	VLVD2	VLVD1	VLVD0
R/W	—	—	R	R/W	—	R/W	R/W	R/W
POR	—	—	0	0	—	0	0	0

- Bit 7~6 Unimplemented, read as “0”
- Bit 5 **LVDO**: LVD output flag
 0: No Low Voltage Detected
 1: Low Voltage Detected
- Bit 4 **LVDEN**: Low Voltage Detector function control
 0: Disable
 1: Enable
- Bit3 Unimplemented, read as “0”
- Bit 2~0 **VLVD2~VLVD0**: Select LVD Reference voltage
 000: 1.8V
 001: 2.0V
 010: 2.4V
 011: 2.7V
 100: 3.0V
 101: 3.3V
 110: 3.6V
 111: 4.0V

LVD Operation

The Low Voltage Detector function operates by comparing the power supply voltage, V_{DD} , with a pre-specified voltage level stored in the LVDC register. This has a range of between 1.8V and 4.0V. When the power supply voltage, V_{DD} , fall below this pre-determined value, the LVDO bit will be set high indicating a low power supply voltage condition. When the device is in the SLEEP mode, the low voltage detector will be disabled even if the LVDEN bit is high. After enabling the Low Voltage Detector, a time delay t_{LVDs} should be allowed for the circuitry to stabilise before reading the LVDO bit. Note also that as the V_{DD} voltage may rise and fall rather slowly, at the voltage nears that of V_{LVD} , there may be multiple bit LVDO transitions.

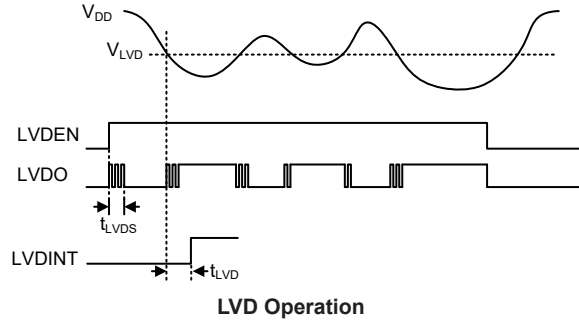

The Low Voltage Detector interrupt is contained within the Multi-function interrupt, providing an alternative means of low voltage detection, in addition to polling the LVDO bit. The interrupt will only be generated after a delay of t_{LVD} after the LVDO bit has been set high by a low voltage condition. When the device is in the SLEEP mode, the low voltage detector will be disabled even if the LVDEN bit is high. In this case, the LVF interrupt request flag will be set, causing an interrupt to be generated if V_{DD} falls below the preset LVD voltage. This will cause the device to wake-up from the IDLE Mode, however if the Low Voltage Detector wake up function is not required then the LVF flag should be first set high before the device enters the IDLE Mode.

24-Bit Analog to Digital Converter

The device contains a high accuracy multi-channel 24-bit Delta Sigma type analog-to-digital converter which can directly interface to external analog signals, such as that from sensors or other control signals and convert these signals directly into a 24-bit digital value. In addition to the core analog to digital converter circuitry, the A/D converter module also includes an internal Programmable Gain Amplifier PGA. The PGA gain control, ADC gain control and ADC reference gain control determine the overall amplification gain for ADC input signal, giving users a flexible way of setting up an overall gain to achieve an optimum amplification of the input signal for their specific applications. The converter has a total of four inputs allowing the formation of two differential input channels. The converter output is filtered via a SINC filter and the result stored as a 24-bit value in three data registers. An internal voltage regulator and reference sources are also included as well as a temperature sensor for A/D converter compensation due to temperature effects.

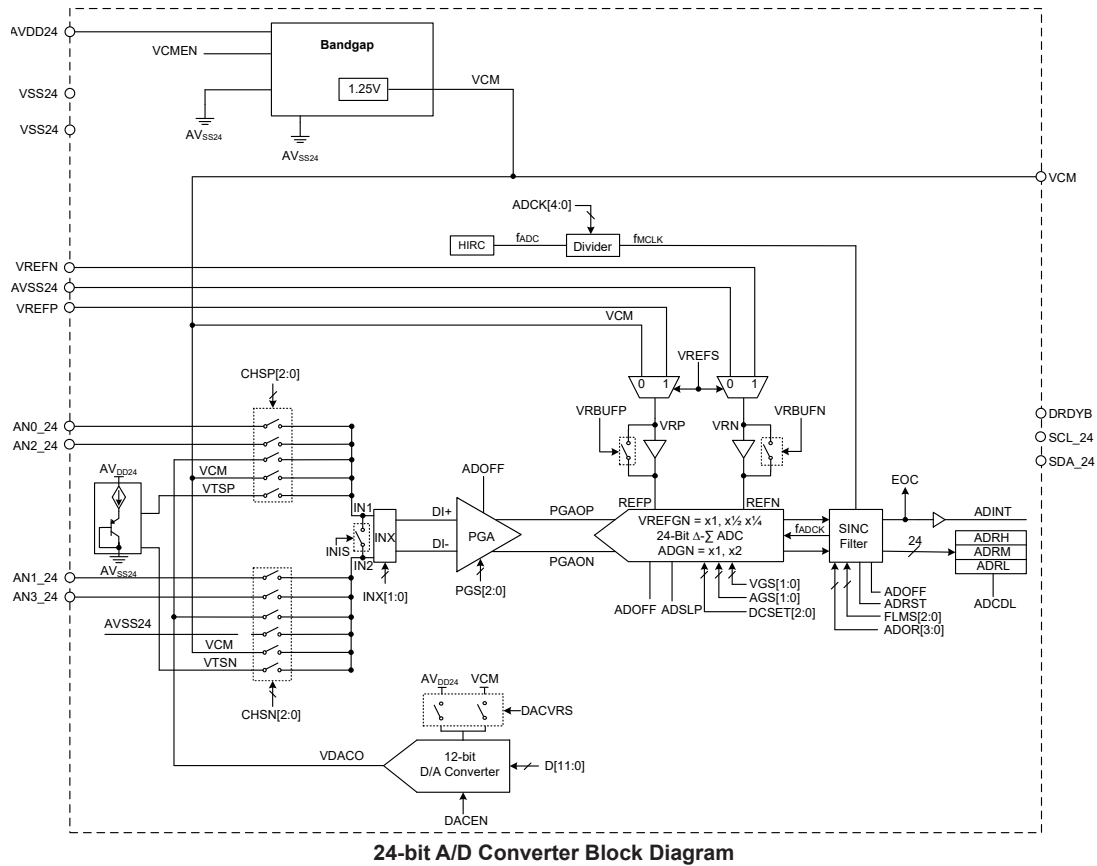

24-bit A/D Converter Block Diagram

24-Bit A/D converter Registers

The A/D converter is setup and operated using a series of internal registers. Device commands and data are written to and read from the 24-bit A/D converter module using its internal I²C bus. This list provides a summary of all internal registers, their detailed operation is described under their relevant section in the following description.

Register Initial Values

The following table shows the internal value of the individual register after a power on reset.

Register	Power On Reset Value
PWRC	0000 0000
PGAC0	-000 0000
PGAC1	-000 000-
PGACS	--00 0000
ADRL	xxxx xxxx
ADRM	xxxx xxxx
ADRH	xxxx xxxx
ADCRO	0010 0000
ADCR1	0000 000-
ADCS	---0 0000
ADCTE	1110 0100
DAH	0000 0000
DAL	---- 0000

Register	Power On Reset Value
DACC	00-- ----
SIMC0	0--- 00--
SIMTOC	0000 0000
HIRCC	---- -001

Note: “*” stands for Warm reset
 “-” stands for Not implemented
 “u” stands for Unchanged
 “x” stands for Unknown

Address	Register Name	Bit							
		7	6	5	4	3	2	1	0
00H	PWRC	VCMEN	D6	D5	D4	D3	D2	D1	D0
01H	PGAC0	—	VGS1	VGS0	AGS1	AGS0	PGS2	PGS1	PGS0
02H	PGAC1	—	INIS	INX1	INX0	DCSET2	DCSET1	DCSET0	—
03H	PGACS	—	—	CHSN2	CHSN1	CHSN0	CHSP2	CHSP1	CHSP0
04H	ADRL	D7	D6	D5	D4	D3	D2	D1	D0
05H	ADRM	D15	D14	D13	D12	D11	D10	D9	D8
06H	ADRH	D23	D22	D21	D20	D20	D19	D18	D17
07H	ADCR0	ADRST	ADSLP	ADOFF	ADOR3	ADOR2	ADOR1	ADOR0	VREFS
08H	ADCR1	FLMS2	FLMS1	FLMS0	VRBUFN	VRBUFP	ADCDL	EOC	—
09H	ADCS	—	—	—	ADCK4	ADCK3	ADCK2	ADCK1	ADCK0
0AH	ADCTE	D7	D6	D5	D4	D3	D2	D1	D0
0BH	DAH	D11	D10	D9	D8	D7	D6	D5	D4
0CH	DAL	—	—	—	—	D3	D2	D1	D0
0DH	DACC	DACEN	DACVRS	—	—	—	—	—	—
0EH	SIMC0	SIMS	—	—	—	SIMDEB1	SIMDEB0	—	—
10H	SIMTOC	SIMTOEN	SIMTOF	SIMTOS5	SIMTOS4	SIMTOS3	SIMTOS2	SIMTOS1	SIMTOS0
11H	HIRCC	—	—	—	—	—	HIRCO	HIRCF	HIRCEN
12H	Reserved, cannot be changed								

Internal Power Supply

This A/D converter module contains the VCM for the regulated power supply. The VCM can be used as the reference voltage for ADC module. The VCM function is controlled by the VCMEN bit and can be powered off to reduce the power consumption.

Reference Voltages

An internal voltage reference source, known as the VCM, is used as a converter reference. The VCM is sourced from a bandgap reference generator thus providing a temperature stable reference and has a output voltage level fixed at 1.25V. The VCM function is controlled by the VCMEN bit and can be switched off to reduce the power consumption.

The converter reference voltage range is supplied on two external reference pins, VREFP and VREFN. These offer a full reference voltage range of AV_{SS24} to AV_{DD24} . This externally supplied reference voltage can be attenuated by 0.5 or 0.25 using the VREFGN bits in the PGAC0 register.

An internal DAC is also provided as an additional reference voltage source. The DAC has two reference voltages which define the maximum value, supplied by either AV_{DD24} or VCM. The DAC 12-bit value is setup using two data registers, DAL and DAH and selected using the DACVRS bit in the DACC register. The overall enable bit for the DAC is the DACEN bit in the DACC register.

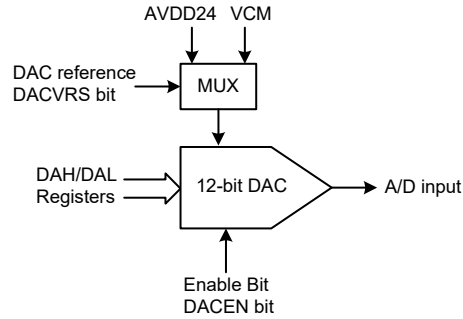

• **DAH Register – 0BH**

Bit	7	6	5	4	3	2	1	0
Name	D11	D10	D9	D8	D7	D6	D5	D4
R/W	R/W	R/W	R/W	R/W	R/W	R/W	R/W	R/W
POR	0	0	0	0	0	0	0	0

Bit 7~0 **D11~D4**: DAC output control code

• **DAL Register – 0CH**

Bit	7	6	5	4	3	2	1	0
Name	—	—	—	—	D3	D2	D1	D0
R/W	—	—	—	—	R/W	R/W	R/W	R/W
POR	—	—	—	—	0	0	0	0

Bit 7~4 Unimplemented, read as “0”

Bit 3~0 **D3~D0**: DAC output control code

Note: writing to this register only writes to a shadow buffer. Not until data is written to the DAH register will the actual data be written into the DAL register.

• **DACC Register – 0DH**

Bit	7	6	5	4	3	2	1	0
Name	DACEN	DACVRS	—	—	—	—	—	—
R/W	R/W	R/W	—	—	—	—	—	—
POR	0	0	—	—	—	—	—	—

Bit 7 **DACEN**: DAC enable or disable control bit
 0: Disable
 1: Enable

Bit 6 **DACVRS**: DAC reference voltage selection
 0: DAC reference voltage sourced from AVDD24
 1: DAC reference voltage sourced from VCM

Bit 5~0 Unimplemented, read as “0”

Power and Reference Control

The following table shows the overall control of the power and voltage sources.

Registers		Output voltage	
ADOFF	VCMEN	Bandgap	VCM
1	0	Off	Disable
1	1	On	Enable
0	0	On	Disable
0	1	On	Enable

Power Control Table

Power Control Registers

• PWRC Register – 00H

Bit	7	6	5	4	3	2	1	0
Name	VCMEN	D6	D5	D4	D3	D2	D1	D0
R/W	R/W	R/W	R/W	R/W	R/W	R/W	R/W	R/W
POR	0	0	0	0	0	0	0	0

Bit 7 **VCMEN**: VCM function enable control

0: Disable

1: Enable

If the VCM is disabled, there will be no power consumption and VCM output pin is floating.

Bit 6~0 **D6~D0**: Performance optimizing bits

010_1000B: when ADCR1[FLMS2~0]=000B ($f_{ADCK}=f_{MCLK}/30$)

011_1100B: when ADCR1[FLMS2~0]=010B ($f_{ADCK}=f_{MCLK}/12$)

others: reserved

Oscillators

There is an fully internal oscillator which provides 4.9152MHz clock frequency in the A/D converter module.

Oscillator Control Registers

There is a control register for the internal oscillator. Note that a full 16 clock cycle time is required for the oscillator to stabilise.

• HIRCC Register – 11H

Bit	7	6	5	4	3	2	1	0
Name	—	—	—	—	—	HIRCO	HIRCF	HIRCEN
R/W	—	—	—	—	—	R/W	R	R/W
POR	—	—	—	—	—	0	0	1

Bit 7~3 Unimplemented, read as “0”

Bit 2 **HIRCO**: HIRC clock output

This bit must be reserved at “0”

Bit 1 **HIRCF**: HIRC oscillator stable flag

0: Unstable

1: Stable

The HIRC stable time will spend 16 clocks when HIRCEN is enabled.

Bit 0 **HIRCEN**: HIRC oscillator enable control

0: Disable

1: Enable

Input Signal Gain Control Amplifier – PGA

An internal programmable gain amplifier is provided to amplify the differential input signal before being converted. All input signals to the analog to digital converter must pass through the PGA. This pre-processing of the input signal enables an optimal signal range to be setup to obtain a converted value with optimal resolution.

PGA Registers

The PGA is controlled using a series of registers to setup the gain value and also to select the input source.

• PGAC0 Register – 01H

Bit	7	6	5	4	3	2	1	0
Name	—	VGS1	VGS0	AGS1	AGS0	PGS2	PGS1	PGS0
R/W	—	R/W	R/W	R/W	R/W	R/W	R/W	R/W
POR	—	0	0	0	0	0	0	0

- Bit 7 Unimplemented, read as “0”
- Bit 6~5 **VGS1~VGS0**: REFP/REFN differential reference voltage gain selection
 00: VREFGN=1
 01: VREFGN=1/2
 10: VREFGN=1/4
 11: Reserved
- Bit 4~3 **AGS1~AGS0**: ADC converter PGAOP/PGAON differential input signal gain selection
 00: ADGN=1
 01: ADGN=2 (for Gain=128=PGAGN×ADGN=64×2)
 10: Reserved
 11: Reserved
- Bit 2~0 **PGS2~PGS0**: PGA DI+/DI- differential channel input gain selection
 000: PGAGN=1
 001: PGAGN=2
 010: PGAGN=4
 011: PGAGN=8
 100: PGAGN=16
 101: PGAGN=32
 110: PGAGN=64
 111: Reserved

• PGAC1 Register – 02H

Bit	7	6	5	4	3	2	1	0
Name	—	INIS	INX1	INX0	DCSET2	DCSET1	DCSET0	—
R/W	—	R/W	R/W	R/W	R/W	R/W	R/W	—
POR	—	0	0	0	0	0	0	—

- Bit 7 Unimplemented, read as “0”
- Bit 6 **INIS**: Selected input terminals IN1/IN2 internal connection
 0: Not connected
 1: Connected
- Bit 5~4 **INX1, INX0**: The selected input ends ,IN1/IN2 and the PGA differential input ends, DI+/DI- connection control bits

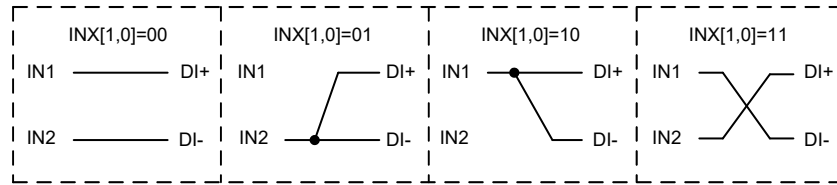

Bit 3~1 **DCSET2~DCSET0:** Differential input signal PGAOP/PGAON offset selection

- 000: DCSET=+0V
- 001: DCSET=+0.25×ΔVR_I
- 010: DCSET=+0.5×ΔVR_I
- 011: DCSET=+0.75×ΔVR_I
- 100: DCSET=+0V
- 101: DCSET=-0.25×ΔVR_I
- 110: DCSET=-0.5×ΔVR_I
- 111: DCSET=-0.75×ΔVR_I

The voltage, ΔVR_I, is the differential reference voltage which is amplified by the specific gain selection based on the selected inputs.

Bit 0 Unimplemented, read as “0”

PGA Input Channel Selection

In addition to the external analog input to be measured by the converter, there are several other internal analog voltage lines which can be connected to the converter. These come from a range of sources such as the temperature sensor and are normally used for calibration purposes.

• **PGACS Register – 03H**

Bit	7	6	5	4	3	2	1	0
Name	—	—	CHSN2	CHSN1	CHSN0	CHSP2	CHSP1	CHSP0
R/W	—	—	R/W	R/W	R/W	R/W	R/W	R/W
POR	—	—	0	0	0	0	0	0

Bit 7~6 Unimplemented, read as “0”

Bit 5~3 **CHSN2~CHSN0:** PGA negative input end IN2 selection

- 000: AN1_24
- 001: AN3_24
- 010: Reserved
- 011: Reserved
- 100: VDACO
- 101: AVSS24
- 110: VCM
- 111: VTSN – Temperature sensor negative output

These bits are used to select the negative input, IN2. If the IN2 input is selected as a single end input, the VCM voltage must be selected as the positive input on IN1 for single end input applications. It is recommended that when the VTSN signal is selected as the negative input, the VTSP signal should be selected as the positive input for proper operations.

Bit 2~0 **CHSP2~CHSP0:** Positive input end IN1 selection

- 000: AN0_24
- 001: AN2_24
- 010: Reserved
- 011: Reserved
- 100: VDACO
- 101: Reserved
- 110: VCM
- 111: VTSP – Temperature sensor positive output

These bits are used to select the positive input, IN1. If the IN1 input is selected as a single end input, the VCM voltage must be selected as the negative input on IN2 for single end input applications. It is recommended that when the VTSP signal is selected as the positive input, the VTSN signal should be selected as the negative input for proper operations.

Analog to Digital Converter Operation

The analog to digital converter received a differential analog signal from the PGA output and converts in using a Delta Sigma converter into a 24-bit digital value. The overall operation of the converter is controlled by a series of control registers.

• ADCR0 Register – 07H

Bit	7	6	5	4	3	2	1	0
Name	ADRST	ADSLP	ADOFF	ADOR3	ADOR2	ADOR1	ADOR0	VREFS
R/W	R/W	R/W	R/W	R/W	R/W	R/W	R/W	R/W
POR	0	0	1	0	0	0	0	0

Bit 7 **ADRST**: A/D converter software reset enable control

- 0: Disable
- 1: Enable

This bit is used to reset the A/D converter internal digital SINC filter. This bit is set low for A/D normal operations. However, if set high, the internal digital SINC filter will be reset and the current A/D converted data will be aborted. A new A/D data conversion process will not be initiated until this bit is set low again.

Bit 6 **ADSLP**: A/D converter sleep mode enable control

- 0: Normal mode
- 1: Sleep mode

This bit is used to determine whether the A/D converter enters the sleep mode or not when the A/D converter is powered on by setting the ADOFF bit low. When the A/D converter is powered on and the ADSLP bit is low, the A/D converter will operate normally. However, the A/D converter will enter the sleep mode if the ADSLP bit is set high as the A/D converter has been powered on. The whole A/D converter circuit will be switched off except the PGA and internal Bandgap circuit to reduce the power consumption and VCM start-up stable time.

Bit 5 **ADOFF**: A/D converter module power on/off control

- 0: Power on
- 1: Power off

This bit controls the power of the A/D converter module. This bit should be cleared to zero to enable the A/D converter. If the bit is set high then the A/D converter will be switched off reducing the device power consumption. As the A/D converter will consume a limited amount of power, even when not executing a conversion, this may be an important consideration in power sensitive battery powered applications.

It is recommended to set the ADOFF bit high before the device enters the IDLE/SLEEP mode for saving power. Setting the ADOFF bit high will power down the A/D converter module regardless of the ADSLP and ADRST bit settings.

Bit 4~1 **ADOR3~ADOR0**: A/D conversion oversampling rate selection

- 0000: Oversampling rate OSR=32768
- 0001: Oversampling rate OSR=16384
- 0010: Oversampling rate OSR=8192
- 0011: Oversampling rate OSR=4096
- 0100: Oversampling rate OSR=2048
- 0101: Oversampling rate OSR=1024
- 0110: Oversampling rate OSR=512
- 0111: Oversampling rate OSR=256
- 1000: Oversampling rate OSR=128
- Others: Reserved

Bit 0 **VREFS**: A/D converter reference voltage pair selection
 0: Internal reference voltage pair – V_{CM} & V_{SS24}
 1: External reference voltage pair – V_{REFP} & V_{REFN}

• **ADCR1 Register – 08H**

Bit	7	6	5	4	3	2	1	0
Name	FLMS2	FLMS1	FLMS0	VRBUFN	VRBUFP	ADCDL	EOC	—
R/W	R/W	R/W	R/W	R/W	R/W	R/W	R/W	—
POR	0	0	0	0	0	0	0	—

Bit 7~5 **FLMS2~FLMS0**: A/D converter clock divided ratio selection
 000: $f_{ADCK}=f_{MCLK}/30$, $N=30$
 010: $f_{ADCK}=f_{MCLK}/12$, $N=12$
 Others: Reserved

Bit 4 **VRBUFN**: A/D converter negative reference voltage input (VRN) buffer control
 0: Disable input buffer and enable bypass function
 1: Enable input buffer and disable bypass function

Bit 3 **VRBUFP**: A/D converter positive reference voltage input (VRP) buffer control
 0: Disable input buffer and enable bypass function
 1: Enable input buffer and disable bypass function

Bit 2 **ADCDL**: A/D converted data latch function enable control
 0: A/D converted data updated
 1: A/D converted data not updated

If the A/D converted data latch function is enabled, the latest converted data value will be latched and not be updated by any subsequent converted results until this function is disabled. Although the converted data is latched into the data registers, the A/D converter circuits remain operational and EOC flag will not change state. It is recommended that this bit should be set high before reading the converted data in the ADRL, ADRM and ADRH registers. After the converted data has been read out, the bit can then be cleared to zero to disable the A/D converter data latch function and allow further conversion values to be stored. In this way, the possibility of obtaining undesired data during A/D converter conversions can be prevented.

Bit 1 **EOC**: End of A/D conversion flag
 0: A/D conversion in progress
 1: A/D conversion ended

This flag will be automatically set high by the hardware when a conversion process has completed but must be cleared by the application software.

Bit 0 Unimplemented, read as “0”

A/D Data Rate Definition

The Delta Sigma ADC data rate can be calculated by the equation list below.

$$\text{Data Rate} = f_{ADCK} / \text{OSR} = (f_{MCLK} / N) / \text{OSR} = f_{MCLK} / (N \times \text{OSR})$$

$$f_{ADCK} = f_{MCLK} / N$$

$$f_{MCLK} = f_{ADC} \text{ or } f_{ADC} / 2 / (\text{ADCK} + 1) \text{ using the ADCK bit field.}$$

N: 30 or 12 determined by the FLMS bit field.

OSR: Oversampling rate determined by the ADOR field.

For example; if a data rate of 10Hz is desired. An f_{MCLK} clock source with a frequency of 4.9152MHz ADC can be selected. Then set the FLMS field to “000” to obtain an “N” equal to 30. Finally, set the ADOR field to “0001” to select an oversampling rate equal to 16384. Therefore, the Data Rate = $4.9152\text{MHz} / (30 \times 16384) = 10\text{Hz}$.

Note that the A/D converter has a notch rejection function for an A/C power supply with a frequency of 50Hz or 60Hz when the data rate is equal to 10Hz.

A/D Converter Clock Source

The clock source for the A/D converter should be typically fixed at a value of 4.9152MHz, which originates from the ADC clock f_{ADC} . This can be chosen to be either f_{ADC} or a subdivision of f_{ADC} . The division ratio value is determined by the ADCK4~ADCK0 bits in the ADCS register to obtain a 4.9152MHz clock source for the ADC.

Internal OSC=4.9152MHz, $f_{ADCK}=f_{MCLK}/30$.

Data Rate (Hz)	ADCK4~0	ADOR3~0	FLMS2~0
10	11111	0001	000

Internal OSC=4.9152MHz, $f_{ADCK}=f_{MCLK}/12$.

Data Rate (Hz)	ADCK4~0	ADOR3~0	FLMS2~0
25	11111	0001	010

• ADCS Register – 09H

Bit	7	6	5	4	3	2	1	0
Name	—	—	—	ADCK4	ADCK3	ADCK2	ADCK1	ADCK0
R/W	—	—	—	R/W	R/W	R/W	R/W	R/W
POR	—	—	—	0	0	0	0	0

Bit 7~5 Unimplemented, read as “0”

Bit 4~0 **ADCK4~ADCK0**: A/D converter clock source f_{MCLK} divided ratio selection
 00000~11110: $f_{MCLK}=f_{ADC}/2/(ADCK[4:0]+1)$
 11111: $f_{MCLK}=f_{ADC}$

• ADCTE Register – 0AH

Bit	7	6	5	4	3	2	1	0
Name	D7	D6	D5	D4	D3	D2	D1	D0
R/W	R/W	R/W	R/W	R/W	R/W	R/W	R/W	R/W
POR	1	1	1	0	0	1	0	0

Bit 7~0 Reserved bits, should be fixed as 1110_0111B.

A/D Operating Modes

The A/D Converter has four operating modes, which are the Normal mode, Power down mode, Sleep mode and Reset mode. These modes are controlled by a combination of the ADOFF, ADSLP and ADRST bits in the ADCR0 register as shown in the accompanying table. The ADOFF controls the overall on/off condition and if high will power down the A/D converter to reduce power. When the ADOFF bit is Low, the converter will be powered on and the ADSLP bit will determine if the converter is in the normal operating mode or in the sleep mode.

ADOFF	ADSLP	ADRST	Operating Mode	Description
1	x	x	Power down mode	Bandgap off, PGA off, ADC off, Temperature sensor off, VRN/VRP buffer off, SINC filter off
0	1	x	Sleep mode	Bandgap on, PGA on, ADC off, Temperature sensor off, VRN/VRP buffer off, SINC filter on
0	0	0	Normal mode	Bandgap on, PGA on, ADC on, Temperature sensor on/off, VRN/VRP buffer on/off, SINC filter on
0	0	1	Reset mode	Bandgap on, PGA on, ADC on, Temperature sensor on/off, VRN/VRP buffer on/off, SINC filter Reset

“x”: unknown

A/D Operating Mode Summary

Note: 1. The VCM generator can be switched on or off by configuring the VCMEN bit.

2. The Temperature sensor can be switched on or off by configuring the CHSN[2:0] or CHSP[2:0] bits
3. The VRN buffer can be switched on or off by configuring the VRBUFN bit while the VRP buffer can be switched on or off by configuring the VRBUFP bit

A/D Conversion Process

To enable the A/D Converter, the first step is to disable the ADC power down and sleep mode by clearing the ADOFF and ADSLP bits to make sure the A/D Converter is powered up. The ADRST bit in the ADCR0 register is used to start and reset the A/D converter after power on. To set ADRST bit from low to high and then low again, an analog to digital converted data in SINC filter will be initiated. After this setup is complete, the A/D Converter is ready for operation. These three bits are used to control the overall start operation of the internal analog to digital converter.

The EOC bit in the ADCR1 register is used to indicate when the analog to digital conversion process is complete. This bit will be automatically set to “1” by the Hardware after a conversion cycle has ended. The ADC converted data will be updated continuously by new converted data. If the ADC converted data latch function is enabled, the latest converted data will be latched and the following new converted data will be discarded until this data latch function is disabled.

The differential reference voltage supply to the A/D Converter can be supplied from either the internal power supply, VCM and AVSS24, or from an external reference source supplied on pins VREFP and VREFN. The desired selection is made using the VREFS bit in the ADCR0 register.

Summary of A/D conversion steps

- Step 1
Enable the power VCM for PGA and ADC.
- Step 2
Select the PGA, ADC, reference voltage gains by PGAC0 register
- Step 3
Select the PGA settings for input connection, VCM voltage level and buffer option by PGAC1 register
- Step 4
Select the required A/D conversion clock source 4.9152MHz by correctly programming bits ADCK4~ADCK0 in the ADCS register.
- Step 5
Select output data rate by configuring the ADOR[2:0] bits in the ADCR0 register and FLMS[2:0] bits in the ADCR1 register.
- Step 6
Select which channel is to be connected to the internal PGA by correctly programming the CHSP2~CHSP0 and CHSN2~CHSN0 bits which are also contained in the PGACS register.
- Step 7
Release the power down mode and sleep mode by clearing the ADOFF and ADSLP bits in ADCR0 register.
- Step 8
Reset the A/D by setting the ADRST to high in the ADCR0 register and clearing this bit to zero to release reset status.
- Step 9
To check when the analog to digital conversion process is complete, the EOC bit in the ADCR1 register can be polled. The conversion process is complete when this bit goes high. When this occurs the A/D data registers ADRL, ADRM and ADRH can then be read to obtain the conversion value.

A/D Transfer Function

As the converted value is 24-bits its full-scale converted digitised value has a decimal value of 8388607 to -8388608. The converted data format is formed by a two’s complement binary value. The MSB of the converted data is the signed bit. Since the full-scale analog input value is equal to the amplified value of the VCM or differential reference input voltage, ΔVR_I , selected by the VREFS bit in ADCR0 register, this gives a single bit analog input value of ΔVR_I divided by 8388608.

$$1 \text{ LSB} = \Delta VR_I / 8388608$$

The A/D Converter input voltage value can be calculated using the following equation:

$$\Delta SI_I = (PGAGN \times ADGN \times \Delta DI_{\pm}) + DCSET$$

$$\Delta VR_I = VREFGN \times \Delta VR_{\pm}$$

$$ADC_Conversion_Data = (\Delta SI_I / \Delta VR_I) \times K$$

Where K is equal to 2^{23} .

- Note: 1. The PGAGN, ADGN, VREFGN values are determined by the PGS, AGS, VGS control bits.
 2. ΔSI_I is the differential input signal after amplification and offset adjustment
 3. PGAGN: Programmable Gain Amplifier gain
 4. ADGN: A/D Converter gain
 5. VREFGN: Reference voltage gain
 6. ΔDI_{\pm} : Differential input signal derived from external channels or internal signals
 7. DCSET: Offset voltage
 8. ΔVR_{\pm} : Differential reference voltage
 9. ΔVR_I : Differential reference input voltage after amplification

Due to the digital system design of the converter, the maximum A/D converted value is 8388607 and the minimum value is -8388608, therefore the centre value is 0. The ADC_Conversion_Data equation illustrates this range of converted data variation.

Converted Data 2's compliment Hex value	Decimal Value
0x7FFFFFFF	8388607
0x800000	-8388608

A/D Conversion Data Range

The following diagram shows the relationship between the DC input value and the ADC converted data which is presented in Two’s Complement format.

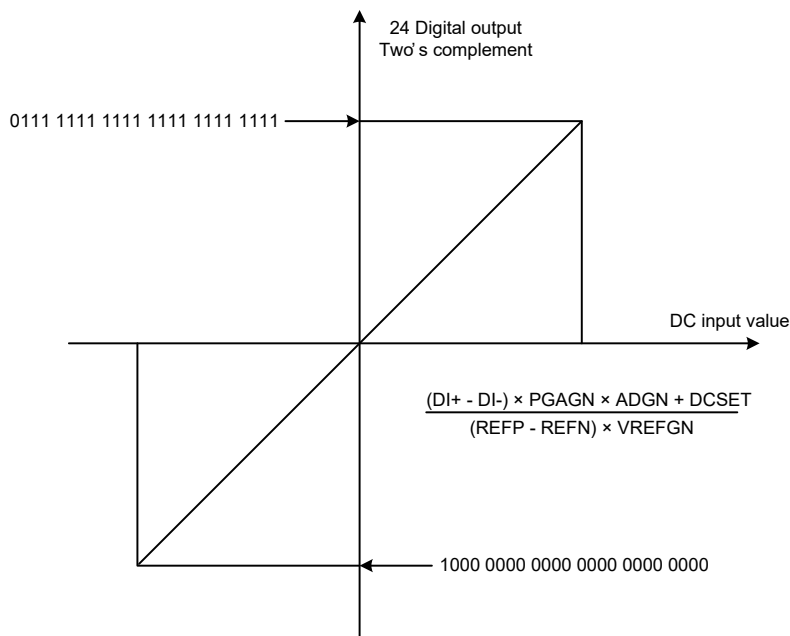

A/D Converted Data

The A/D converter data is stored in three individual registers, ADRL, ADRM and ADRH. The converted data is related to the input voltage and the PGA selection setup and is generated in a two's complement binary code format. The length of this output code is 24 bits and the MSB is a signed bit. When the MSB is "0", this indicates that the input is "positive", while if the MSB is "1", this indicates that the input is "negative". The maximum value is 8388607 and the minimum value is -8388608. If the input signal exceeds the maximum value, the converted data is limited to 8388607, and if the input signal is less than the minimum value, the converted data is limited to -8388608.

• ADRL Register – 04H

Bit	7	6	5	4	3	2	1	0
Name	D7	D6	D5	D4	D3	D2	D1	D0
R/W	R	R	R	R	R	R	R	R
POR	x	x	x	x	x	x	x	x

Bit 7~0 A/D conversion data register bit 7~bit 0

• ADRM Register – 05H

Bit	7	6	5	4	3	2	1	0
Name	D15	D14	D13	D12	D11	D10	D9	D8
R/W	R	R	R	R	R	R	R	R
POR	x	x	x	x	x	x	x	x

Bit 7~0 A/D conversion data register bit 15~bit 8

• ADRH Register – 06H

Bit	7	6	5	4	3	2	1	0
Name	D23	D22	D21	D20	D19	D18	D17	D16
R/W	R	R	R	R	R	R	R	R
POR	x	x	x	x	x	x	x	x

Bit 7~0 A/D conversion data register bit 23~bit 16

Converting the Digital Value to a Voltage

The analog voltage value can be recovered using the following equations:

If the MSB=0 for positive value converted data:

$$\text{Input Voltage} = \frac{(\text{Converted_data}) \times \text{LSB} - \text{DCSET}}{\text{PGA} \times \text{ADGN}}$$

If the MSB=1 for negative converted data:

$$\text{Input voltage} = \frac{(\text{Two's_complement_of_Converted_data}) \times \text{LSB} - \text{DCSET}}{\text{PGA} \times \text{ADGN}}$$

Note: Two's complement=One's complement+1

Temperature Sensor

The A/D converter module includes a fully internal temperature sensor to allow for compensation due to temperature effects. By selecting the PGA input channels to VTSP and VTSN signals, the A/D Converter can obtain temperature information and then use the result to compensate the A/D converted data to minimise the effects of temperature.

Effective Number of Bits – ENOB

Although the analog to digital converter is a 24-bit type various factors such as the PGA gain and the data rate affect the actual number of effective number of converted bits.

Programming Considerations

During microcontroller operations where the A/D converter is not being used, the A/D internal circuitry can be switched off to reduce power consumption, by setting bit ADOFF high in the ADCR0 register. When this happens, the internal A/D converter circuits will not consume power irrespective of what analog voltage is applied to their input lines.

When writing to the DAC registers, DAH and DAL, note that this must be carried out in a special sequence. This is because when writing to the DAL register, the data is only written into a shadow buffer register. Only when data is written to the DAH register will data in the shadow buffer be transferred to the DAL register. Therefore when writing data to the DAC registers first write data to the DAL register and then to the DAH register.

External Interface Communication

The A/D converter module communicates with external hardware using its internal I²C interface. Originally developed by Philips, the I²C interface is a two line low speed serial interface for synchronous serial data transfer. With the advantage of only two lines for communication, a relatively simple communication protocol and the ability to accommodate multiple devices on the same bus has made it an extremely popular interface type for many applications.

I²C Interface Operation

The I²C serial interface is a two line interface, a serial data line, SDA₂₄, and serial clock line, SCL₂₄. As many devices may be connected together on the same bus, their outputs are both open drain types. For this reason it is necessary that external pull-high resistors are connected to these outputs. Note that no chip select line exists, as each device on the I²C bus is identified by a unique address which will be transmitted and received on the I²C bus. When two devices communicate with each other on the bidirectional I²C bus, one is known as the master device and one as the slave device. Both master and slave can transmit and receive data, however, it is the master A/D converter module that has overall control of the bus, and it is only the master that will drive the SCL₂₄ clock line. This device only operates in the slave mode, and will therefore only operate in response to the master. There are two methods for this A/D converter module to transfer data on the I²C bus, the slave transmit mode and the slave receive mode.

Several registers control the overall operation of the I²C bus interface.

I²C Address and Register Write/Read

I²C Address Selection

As this A/D converter module only operates as a slave, and as it may be connected to a common I²C bus along with other I²C devices, it will require a specific address for it to be communicated to by the external master. The I²C address of the A/D converter module is fixed at 0xD0.

• SIMC0 Register – 0EH

Bit	7	6	5	4	3	2	1	0
Name	SIMS	—	—	—	SIMDEB1	SIMDEB0	—	—
R/W	R/W	—	—	—	R/W	R/W	—	—
POR	0	—	—	—	0	0	—	—

- Bit 7 **SIMS:**
 0: Normal operation
 1: Results in unpredictable behavior
 This bit must be kept at a zero value for normal operation
- Bit 6~4 Unimplemented, read as “0”
- Bit 3~2 **SIMDEB1~SIMDEB0:** I²C debounce time selection
 00: No debounce
 01: 2 ADC clock debounce
 10: 4 ADC clock debounce
 11: 4 ADC clock debounce
- Bit 1~0 Unimplemented, read as “0”

Start and Stop Operations

Normally the SDA₂₄ line can only change when the SCL₂₄ line is low. There are two exceptions however and that is for the Start and Stop operations, where the SCL₂₄ line will be forced high by the master and the SDA₂₄ line will change state. As the diagram shows when the SCL₂₄ line is high, a high to low SDA₂₄ line transition indicates a start operation and a low to high SDA₂₄ line transition indicates a stop operation.

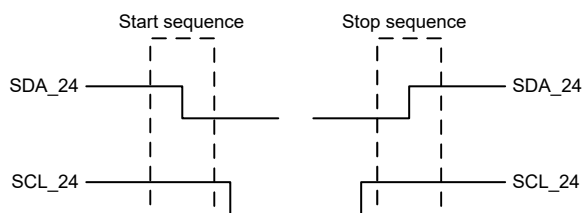

I²C Bus Data Transfer

Data is transferred on the I²C bus in 8 bit packets, first transmitting the MSB which is the most significant bit and lastly the LSB bit, the least significant bit. When the data has been setup on the SDA₂₄ line, the SCL₂₄ line then generates a high pulse to latch the data. When the SCL₂₄ line is high the SDA₂₄ line is not permitted to change state. After 8-bits have been transmitted, the device will then send a 9th bit which is the acknowledge bit. Therefore in total there are 9 bits transmitted and subsequently 9 SCL₂₄ clock pulses to transfer each 8-bits or byte of data. When the receiving device sends back a low ACK bit, this is to acknowledge that it has received the 8-bits of data and is ready to receive another byte. If a high ACK bit is sent back, this indicates that it is unable to receive any further data and the master should then send a stop sequence.

I²C Register Write/Read

• Write Process

Bit	7	6	5	4	3	2	1	0	7	6	5	4	3	2	1	0	7	6	5	4	3	2	1	0					
Start	Device Address								Write	ACK	Register Address								ACK	Register Data								ACK	Stop

• Read Process

Bit	7	6	5	4	3	2	1	0	7	6	5	4	3	2	1	0			7	6	5	4	3	2	1	0	7	6	5	4	3	2	1	0						
Start	Device Address								Write	ACK	Register Address								ACK	Start	Device Address								Read	ACK	Register Data								ACK	Stop

I²C Bus Start Signal

The START signal can only be generated by the master device connected to the I²C bus and not by the slave device. This START signal will be detected by all devices connected to the I²C bus. A START condition occurs when a high to low transition on the SDA_24 line takes place when the SCL_24 line remains high.

Slave Address

The transmission of a START signal by the master will be detected by all devices on the I²C bus. To determine which slave device the master wishes to communicate with, the address of the slave device will be sent out immediately following the START signal.

I²C Bus Slave Address Acknowledge Signal

After the master has transmitted a calling address, any slave device on the I²C bus, whose own internal address matches the calling address, must generate an acknowledge signal. The acknowledge signal will inform the master that a slave device has accepted its calling address. If no acknowledge signal is received by the master then a STOP signal must be transmitted by the master to end the communication.

I²C Bus Data and Acknowledge Signal

The transmitted data is 8-bits wide and is transmitted after the slave device has acknowledged receipt of its slave address. The order of serial bit transmission is the MSB first and the LSB last. After receipt of 8-bits of data, the receiver must transmit an acknowledge signal, level 0, before it can receive the next data byte. If the slave transmitter does not receive an acknowledge bit signal from the master receiver, then the slave transmitter will release the SDA_24 line to allow the master to send a STOP signal to release the I²C Bus.

I²C Timeout Function

The I²C interface includes a timeout function which is controlled by a single register. This register sets the overall enable/disable function as well as the timeout value in ADC clock units. Determining whether the I²C bus has timed out is implemented by reading the SIMTOF bit. This bit will be automatically set high when the I²C bus times out, but needs to be cleared manually by the application program.

• **SIMTOC Register – 10H**

Bit	7	6	5	4	3	2	1	0
Name	SIMTOEN	SIMTOF	SIMTOS5	SIMTOS4	SIMTOS3	SIMTOS2	SIMTOS1	SIMTOS0
R/W	R/W	R/W	R/W	R/W	R/W	R/W	R/W	R/W
POR	0	0	0	0	0	0	0	0

Bit 7 **SIMTOEN**: I²C time-out control

0: Disable

1: Enable

Bit 6 **SIMTOF**: I²C time-out flag

0: Not occurred

1: Occurred

The bit is set by time-out function and is cleared by the application program.

Bit 5~0 **SIMTOS5~SIMTOS0**: I²C time-out selection time

The I²C Time-Out clock source is $f_{SUB}/32$. ($f_{SUB}=f_{ADC}/128$)

The I²C Time-Out time is $([SIMTOS5:SIMTOS0]+1) \times (32/f_{SUB})$

Configuration Options

Configuration options refer to certain options within the MCU that are programmed into the device during the programming process. During the development process, these options are selected using the HT-IDE software development tools. All options must be defined for proper system function, the details of which are shown in the table.

No.	Options
Oscillator Option	
1	HIRC frequency selection – f_{HIRC} : 8MHz, 12MHz or 16MHz

Note: When the HIRC has been configured at a frequency shown in this table, the HIRC1 and HIRC0 bits should also be setup to select the same frequency to achieve the HIRC frequency accuracy specified in the A.C. Characteristics.

Application Circuits

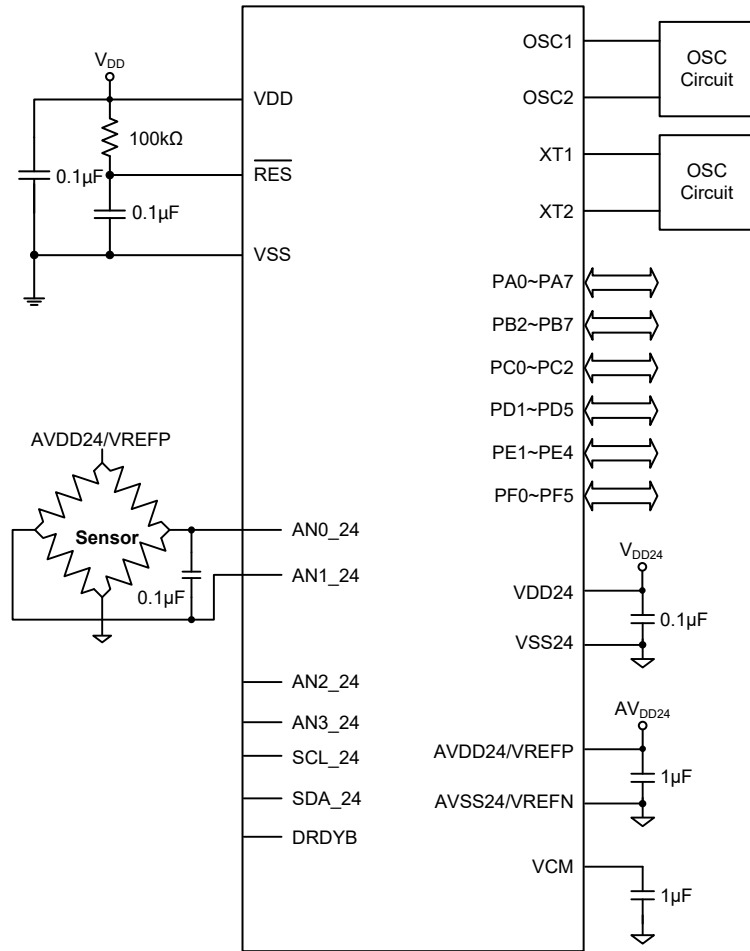

Instruction Set

Introduction

Central to the successful operation of any microcontroller is its instruction set, which is a set of program instruction codes that directs the microcontroller to perform certain operations. In the case of Holtek microcontroller, a comprehensive and flexible set of over 60 instructions is provided to enable programmers to implement their application with the minimum of programming overheads.

For easier understanding of the various instruction codes, they have been subdivided into several functional groupings.

Instruction Timing

Most instructions are implemented within one instruction cycle. The exceptions to this are branch, call, or table read instructions where two instruction cycles are required. One instruction cycle is equal to 4 system clock cycles, therefore in the case of an 8MHz system oscillator, most instructions would be implemented within 0.5 μ s and branch or call instructions would be implemented within 1 μ s. Although instructions which require one more cycle to implement are generally limited to the JMP, CALL, RET, RETI and table read instructions, it is important to realize that any other instructions which involve manipulation of the Program Counter Low register or PCL will also take one more cycle to implement. As instructions which change the contents of the PCL will imply a direct jump to that new address, one more cycle will be required. Examples of such instructions would be “CLR PCL” or “MOV PCL, A”. For the case of skip instructions, it must be noted that if the result of the comparison involves a skip operation then this will also take one more cycle, if no skip is involved then only one cycle is required.

Moving and Transferring Data

The transfer of data within the microcontroller program is one of the most frequently used operations. Making use of several kinds of MOV instructions, data can be transferred from registers to the Accumulator and vice-versa as well as being able to move specific immediate data directly into the Accumulator. One of the most important data transfer applications is to receive data from the input ports and transfer data to the output ports.

Arithmetic Operations

The ability to perform certain arithmetic operations and data manipulation is a necessary feature of most microcontroller applications. Within the Holtek microcontroller instruction set are a range of add and subtract instruction mnemonics to enable the necessary arithmetic to be carried out. Care must be taken to ensure correct handling of carry and borrow data when results exceed 255 for addition and less than 0 for subtraction. The increment and decrement instructions such as INC, INCA, DEC and DECA provide a simple means of increasing or decreasing by a value of one of the values in the destination specified.

Logical and Rotate Operation

The standard logical operations such as AND, OR, XOR and CPL all have their own instruction within the Holtek microcontroller instruction set. As with the case of most instructions involving data manipulation, data must pass through the Accumulator which may involve additional programming steps. In all logical data operations, the zero flag may be set if the result of the operation is zero. Another form of logical data manipulation comes from the rotate instructions such as RR, RL, RRC and RLC which provide a simple means of rotating one bit right or left. Different rotate instructions exist depending on program requirements. Rotate instructions are useful for serial port programming applications where data can be rotated from an internal register into the Carry bit from where it can be examined and the necessary serial bit set high or low. Another application which rotate data operations are used is to implement multiplication and division calculations.

Branches and Control Transfer

Program branching takes the form of either jumps to specified locations using the JMP instruction or to a subroutine using the CALL instruction. They differ in the sense that in the case of a subroutine call, the program must return to the instruction immediately when the subroutine has been carried out. This is done by placing a return instruction “RET” in the subroutine which will cause the program to jump back to the address right after the CALL instruction. In the case of a JMP instruction, the program simply jumps to the desired location. There is no requirement to jump back to the original jumping off point as in the case of the CALL instruction. One special and extremely useful set of branch instructions are the conditional branches. Here a decision is first made regarding the condition of a certain data memory or individual bits. Depending upon the conditions, the program will continue with the next instruction or skip over it and jump to the following instruction. These instructions are the key to decision making and branching within the program perhaps determined by the condition of certain input switches or by the condition of internal data bits.

Bit Operations

The ability to provide single bit operations on Data Memory is an extremely flexible feature of all Holtek microcontrollers. This feature is especially useful for output port bit programming where individual bits or port pins can be directly set high or low using either the “SET [m].i” or “CLR [m].i” instructions respectively. The feature removes the need for programmers to first read the 8-bit output port, manipulate the input data to ensure that other bits are not changed and then output the port with the correct new data. This read-modify-write process is taken care of automatically when these bit operation instructions are used.

Table Read Operations

Data storage is normally implemented by using registers. However, when working with large amounts of fixed data, the volume involved often makes it inconvenient to store the fixed data in the Data Memory. To overcome this problem, Holtek microcontrollers allow an area of Program Memory to be setup as a table where data can be directly stored. A set of easy to use instructions provides the means by which this fixed data can be referenced and retrieved from the Program Memory.

Other Operations

In addition to the above functional instructions, a range of other instructions also exist such as the “HALT” instruction for Power-down operations and instructions to control the operation of the Watchdog Timer for reliable program operations under extreme electric or electromagnetic environments. For their relevant operations, refer to the functional related sections.

Instruction Set Summary

The instructions related to the data memory access in the following table can be used when the desired data memory is located in Data Memory sector 0.

Table Conventions

x: Bits immediate data
m: Data Memory address
A: Accumulator
i: 0~7 number of bits
addr: Program memory address

Mnemonic	Description	Cycles	Flag Affected
Arithmetic			
ADD A,[m]	Add Data Memory to ACC	1	Z, C, AC, OV, SC
ADDM A,[m]	Add ACC to Data Memory	1 ^{Note}	Z, C, AC, OV, SC
ADD A,x	Add immediate data to ACC	1	Z, C, AC, OV, SC
ADC A,[m]	Add Data Memory to ACC with Carry	1	Z, C, AC, OV, SC
ADCM A,[m]	Add ACC to Data memory with Carry	1 ^{Note}	Z, C, AC, OV, SC
SUB A,x	Subtract immediate data from the ACC	1	Z, C, AC, OV, SC, CZ
SUB A,[m]	Subtract Data Memory from ACC	1	Z, C, AC, OV, SC, CZ
SUBM A,[m]	Subtract Data Memory from ACC with result in Data Memory	1 ^{Note}	Z, C, AC, OV, SC, CZ
SBC A,x	Subtract immediate data from ACC with Carry	1	Z, C, AC, OV, SC, CZ
SBC A,[m]	Subtract Data Memory from ACC with Carry	1	Z, C, AC, OV, SC, CZ
SBCM A,[m]	Subtract Data Memory from ACC with Carry, result in Data Memory	1 ^{Note}	Z, C, AC, OV, SC, CZ
DAA [m]	Decimal adjust ACC for Addition with result in Data Memory	1 ^{Note}	C
Logic Operation			
AND A,[m]	Logical AND Data Memory to ACC	1	Z
OR A,[m]	Logical OR Data Memory to ACC	1	Z
XOR A,[m]	Logical XOR Data Memory to ACC	1	Z
ANDM A,[m]	Logical AND ACC to Data Memory	1 ^{Note}	Z
ORM A,[m]	Logical OR ACC to Data Memory	1 ^{Note}	Z
XORM A,[m]	Logical XOR ACC to Data Memory	1 ^{Note}	Z
AND A,x	Logical AND immediate Data to ACC	1	Z
OR A,x	Logical OR immediate Data to ACC	1	Z
XOR A,x	Logical XOR immediate Data to ACC	1	Z
CPL [m]	Complement Data Memory	1 ^{Note}	Z
CPLA [m]	Complement Data Memory with result in ACC	1	Z
Increment & Decrement			
INCA [m]	Increment Data Memory with result in ACC	1	Z
INC [m]	Increment Data Memory	1 ^{Note}	Z
DECA [m]	Decrement Data Memory with result in ACC	1	Z
DEC [m]	Decrement Data Memory	1 ^{Note}	Z
Rotate			
RRA [m]	Rotate Data Memory right with result in ACC	1	None
RR [m]	Rotate Data Memory right	1 ^{Note}	None
RRCA [m]	Rotate Data Memory right through Carry with result in ACC	1	C
RRC [m]	Rotate Data Memory right through Carry	1 ^{Note}	C
RLA [m]	Rotate Data Memory left with result in ACC	1	None
RL [m]	Rotate Data Memory left	1 ^{Note}	None
RLCA [m]	Rotate Data Memory left through Carry with result in ACC	1	C
RLC [m]	Rotate Data Memory left through Carry	1 ^{Note}	C

Mnemonic	Description	Cycles	Flag Affected
Data Move			
MOV A,[m]	Move Data Memory to ACC	1	None
MOV [m],A	Move ACC to Data Memory	1 ^{Note}	None
MOV A,x	Move immediate data to ACC	1	None
Bit Operation			
CLR [m].i	Clear bit of Data Memory	1 ^{Note}	None
SET [m].i	Set bit of Data Memory	1 ^{Note}	None
Branch Operation			
JMP addr	Jump unconditionally	2	None
SZ [m]	Skip if Data Memory is zero	1 ^{Note}	None
SZA [m]	Skip if Data Memory is zero with data movement to ACC	1 ^{Note}	None
SZ [m].i	Skip if bit i of Data Memory is zero	1 ^{Note}	None
SNZ [m]	Skip if Data Memory is not zero	1 ^{Note}	None
SNZ [m].i	Skip if bit i of Data Memory is not zero	1 ^{Note}	None
SIZ [m]	Skip if increment Data Memory is zero	1 ^{Note}	None
SDZ [m]	Skip if decrement Data Memory is zero	1 ^{Note}	None
SIZA [m]	Skip if increment Data Memory is zero with result in ACC	1 ^{Note}	None
SDZA [m]	Skip if decrement Data Memory is zero with result in ACC	1 ^{Note}	None
CALL addr	Subroutine call	2	None
RET	Return from subroutine	2	None
RET A,x	Return from subroutine and load immediate data to ACC	2	None
RETI	Return from interrupt	2	None
Table Read Operation			
TABRD [m]	Read table (specific page) to TBLH and Data Memory	2 ^{Note}	None
TABRD L [m]	Read table (last page) to TBLH and Data Memory	2 ^{Note}	None
ITABRD [m]	Increment table pointer TBLP first and Read table (specific page) to TBLH and Data Memory	2 ^{Note}	None
ITABRD L [m]	Increment table pointer TBLP first and Read table (last page) to TBLH and Data Memory	2 ^{Note}	None
Miscellaneous			
NOP	No operation	1	None
CLR [m]	Clear Data Memory	1 ^{Note}	None
SET [m]	Set Data Memory	1 ^{Note}	None
CLR WDT	Clear Watchdog Timer	1	TO, PDF
SWAP [m]	Swap nibbles of Data Memory	1 ^{Note}	None
SWAPA [m]	Swap nibbles of Data Memory with result in ACC	1	None
HALT	Enter power down mode	1	TO, PDF

Note: 1. For skip instructions, if the result of the comparison involves a skip then two cycles are required, if no skip takes place only one cycle is required.

2. Any instruction which changes the contents of the PCL will also require 2 cycles for execution.

Extended Instruction Set

The extended instructions are used to support the full range address access for the data memory. When the accessed data memory is located in any data memory sector except sector 0, the extended instruction can be used to directly access the data memory instead of using the indirect addressing access. This can not only reduce the use of Flash memory space but also improve the CPU execution efficiency.

Mnemonic	Description	Cycles	Flag Affected
Arithmetic			
LADD A,[m]	Add Data Memory to ACC	2	Z, C, AC, OV, SC
LADDM A,[m]	Add ACC to Data Memory	2 ^{Note}	Z, C, AC, OV, SC
LADC A,[m]	Add Data Memory to ACC with Carry	2	Z, C, AC, OV, SC
LADCM A,[m]	Add ACC to Data memory with Carry	2 ^{Note}	Z, C, AC, OV, SC
LSUB A,[m]	Subtract Data Memory from ACC	2	Z, C, AC, OV, SC, CZ
LSUBM A,[m]	Subtract Data Memory from ACC with result in Data Memory	2 ^{Note}	Z, C, AC, OV, SC, CZ
LSBC A,[m]	Subtract Data Memory from ACC with Carry	2	Z, C, AC, OV, SC, CZ
LSBCM A,[m]	Subtract Data Memory from ACC with Carry, result in Data Memory	2 ^{Note}	Z, C, AC, OV, SC, CZ
LDAA [m]	Decimal adjust ACC for Addition with result in Data Memory	2 ^{Note}	C
Logic Operation			
LAND A,[m]	Logical AND Data Memory to ACC	2	Z
LOR A,[m]	Logical OR Data Memory to ACC	2	Z
LXOR A,[m]	Logical XOR Data Memory to ACC	2	Z
LANDM A,[m]	Logical AND ACC to Data Memory	2 ^{Note}	Z
LORM A,[m]	Logical OR ACC to Data Memory	2 ^{Note}	Z
LXORM A,[m]	Logical XOR ACC to Data Memory	2 ^{Note}	Z
LCPL [m]	Complement Data Memory	2 ^{Note}	Z
LCPLA [m]	Complement Data Memory with result in ACC	2	Z
Increment & Decrement			
LINCA [m]	Increment Data Memory with result in ACC	2	Z
LINC [m]	Increment Data Memory	2 ^{Note}	Z
LDECA [m]	Decrement Data Memory with result in ACC	2	Z
LDEC [m]	Decrement Data Memory	2 ^{Note}	Z
Rotate			
LRRRA [m]	Rotate Data Memory right with result in ACC	2	None
LRR [m]	Rotate Data Memory right	2 ^{Note}	None
LRRCA [m]	Rotate Data Memory right through Carry with result in ACC	2	C
LRRC [m]	Rotate Data Memory right through Carry	2 ^{Note}	C
LRLA [m]	Rotate Data Memory left with result in ACC	2	None
LRL [m]	Rotate Data Memory left	2 ^{Note}	None
LRLCA [m]	Rotate Data Memory left through Carry with result in ACC	2	C
LRLC [m]	Rotate Data Memory left through Carry	2 ^{Note}	C
Data Move			
LMOV A,[m]	Move Data Memory to ACC	2	None
LMOV [m],A	Move ACC to Data Memory	2 ^{Note}	None
Bit Operation			
LCLR [m].i	Clear bit of Data Memory	2 ^{Note}	None
LSET [m].i	Set bit of Data Memory	2 ^{Note}	None

Mnemonic	Description	Cycles	Flag Affected
Branch			
LSZ [m]	Skip if Data Memory is zero	2 ^{Note}	None
LSZA [m]	Skip if Data Memory is zero with data movement to ACC	2 ^{Note}	None
LSNZ [m]	Skip if Data Memory is not zero	2 ^{Note}	None
LSZ [m].i	Skip if bit i of Data Memory is zero	2 ^{Note}	None
LSNZ [m].i	Skip if bit i of Data Memory is not zero	2 ^{Note}	None
LSIZ [m]	Skip if increment Data Memory is zero	2 ^{Note}	None
LSDZ [m]	Skip if decrement Data Memory is zero	2 ^{Note}	None
LSIZA [m]	Skip if increment Data Memory is zero with result in ACC	2 ^{Note}	None
LSDZA [m]	Skip if decrement Data Memory is zero with result in ACC	2 ^{Note}	None
Table Read			
LTABRD [m]	Read table (specific page) to TBLH and Data Memory	3 ^{Note}	None
LTABRDL [m]	Read table (last page) to TBLH and Data Memory	3 ^{Note}	None
LITABRD [m]	Increment table pointer TBLP first and Read table (specific page) to TBLH and Data Memory	3 ^{Note}	None
LITABRDL [m]	Increment table pointer TBLP first and Read table (last page) to TBLH and Data Memory	3 ^{Note}	None
Miscellaneous			
LCLR [m]	Clear Data Memory	2 ^{Note}	None
LSET [m]	Set Data Memory	2 ^{Note}	None
LSWAP [m]	Swap nibbles of Data Memory	2 ^{Note}	None
LSWAPA [m]	Swap nibbles of Data Memory with result in ACC	2	None

Note: 1. For these extended skip instructions, if the result of the comparison involves a skip then three cycles are required, if no skip takes place two cycles is required.

2. Any extended instruction which changes the contents of the PCL register will also require three cycles for execution.

Instruction Definition

ADC A,[m]	Add Data Memory to ACC with Carry
Description	The contents of the specified Data Memory, Accumulator and the carry flag are added. The result is stored in the Accumulator.
Operation	$ACC \leftarrow ACC + [m] + C$
Affected flag(s)	OV, Z, AC, C, SC
ADCM A,[m]	Add ACC to Data Memory with Carry
Description	The contents of the specified Data Memory, Accumulator and the carry flag are added. The result is stored in the specified Data Memory.
Operation	$[m] \leftarrow ACC + [m] + C$
Affected flag(s)	OV, Z, AC, C, SC
ADD A,[m]	Add Data Memory to ACC
Description	The contents of the specified Data Memory and the Accumulator are added. The result is stored in the Accumulator.
Operation	$ACC \leftarrow ACC + [m]$
Affected flag(s)	OV, Z, AC, C, SC
ADD A,x	Add immediate data to ACC
Description	The contents of the Accumulator and the specified immediate data are added. The result is stored in the Accumulator.
Operation	$ACC \leftarrow ACC + x$
Affected flag(s)	OV, Z, AC, C, SC
ADDM A,[m]	Add ACC to Data Memory
Description	The contents of the specified Data Memory and the Accumulator are added. The result is stored in the specified Data Memory.
Operation	$[m] \leftarrow ACC + [m]$
Affected flag(s)	OV, Z, AC, C, SC
AND A,[m]	Logical AND Data Memory to ACC
Description	Data in the Accumulator and the specified Data Memory perform a bitwise logical AND operation. The result is stored in the Accumulator.
Operation	$ACC \leftarrow ACC \text{ "AND" } [m]$
Affected flag(s)	Z
AND A,x	Logical AND immediate data to ACC
Description	Data in the Accumulator and the specified immediate data perform a bit wise logical AND operation. The result is stored in the Accumulator.
Operation	$ACC \leftarrow ACC \text{ "AND" } x$
Affected flag(s)	Z
ANDM A,[m]	Logical AND ACC to Data Memory
Description	Data in the specified Data Memory and the Accumulator perform a bitwise logical AND operation. The result is stored in the Data Memory.
Operation	$[m] \leftarrow ACC \text{ "AND" } [m]$
Affected flag(s)	Z

CALL addr	Subroutine call
Description	Unconditionally calls a subroutine at the specified address. The Program Counter then increments by 1 to obtain the address of the next instruction which is then pushed onto the stack. The specified address is then loaded and the program continues execution from this new address. As this instruction requires an additional operation, it is a two cycle instruction.
Operation	Stack \leftarrow Program Counter + 1 Program Counter \leftarrow addr
Affected flag(s)	None
CLR [m]	Clear Data Memory
Description	Each bit of the specified Data Memory is cleared to 0.
Operation	[m] \leftarrow 00H
Affected flag(s)	None
CLR [m].i	Clear bit of Data Memory
Description	Bit i of the specified Data Memory is cleared to 0.
Operation	[m].i \leftarrow 0
Affected flag(s)	None
CLR WDT	Clear Watchdog Timer
Description	The TO, PDF flags and the WDT are all cleared.
Operation	WDT cleared TO \leftarrow 0 PDF \leftarrow 0
Affected flag(s)	TO, PDF
CPL [m]	Complement Data Memory
Description	Each bit of the specified Data Memory is logically complemented (1's complement). Bits which previously contained a 1 are changed to 0 and vice versa.
Operation	[m] \leftarrow $\overline{[m]}$
Affected flag(s)	Z
CPLA [m]	Complement Data Memory with result in ACC
Description	Each bit of the specified Data Memory is logically complemented (1's complement). Bits which previously contained a 1 are changed to 0 and vice versa. The complemented result is stored in the Accumulator and the contents of the Data Memory remain unchanged.
Operation	ACC \leftarrow $\overline{[m]}$
Affected flag(s)	Z
DAA [m]	Decimal-Adjust ACC for addition with result in Data Memory
Description	Convert the contents of the Accumulator value to a BCD (Binary Coded Decimal) value resulting from the previous addition of two BCD variables. If the low nibble is greater than 9 or if AC flag is set, then a value of 6 will be added to the low nibble. Otherwise the low nibble remains unchanged. If the high nibble is greater than 9 or if the C flag is set, then a value of 6 will be added to the high nibble. Essentially, the decimal conversion is performed by adding 00H, 06H, 60H or 66H depending on the Accumulator and flag conditions. Only the C flag may be affected by this instruction which indicates that if the original BCD sum is greater than 100, it allows multiple precision decimal addition.
Operation	[m] \leftarrow ACC + 00H or [m] \leftarrow ACC + 06H or [m] \leftarrow ACC + 60H or [m] \leftarrow ACC + 66H
Affected flag(s)	C

DEC [m]	Decrement Data Memory
Description	Data in the specified Data Memory is decremented by 1.
Operation	$[m] \leftarrow [m] - 1$
Affected flag(s)	Z
DECA [m]	Decrement Data Memory with result in ACC
Description	Data in the specified Data Memory is decremented by 1. The result is stored in the Accumulator. The contents of the Data Memory remain unchanged.
Operation	$ACC \leftarrow [m] - 1$
Affected flag(s)	Z
HALT	Enter power down mode
Description	This instruction stops the program execution and turns off the system clock. The contents of the Data Memory and registers are retained. The WDT and prescaler are cleared. The power down flag PDF is set and the WDT time-out flag TO is cleared.
Operation	$TO \leftarrow 0$ $PDF \leftarrow 1$
Affected flag(s)	TO, PDF
INC [m]	Increment Data Memory
Description	Data in the specified Data Memory is incremented by 1.
Operation	$[m] \leftarrow [m] + 1$
Affected flag(s)	Z
INCA [m]	Increment Data Memory with result in ACC
Description	Data in the specified Data Memory is incremented by 1. The result is stored in the Accumulator. The contents of the Data Memory remain unchanged.
Operation	$ACC \leftarrow [m] + 1$
Affected flag(s)	Z
JMP addr	Jump unconditionally
Description	The contents of the Program Counter are replaced with the specified address. Program execution then continues from this new address. As this requires the insertion of a dummy instruction while the new address is loaded, it is a two cycle instruction.
Operation	Program Counter \leftarrow addr
Affected flag(s)	None
MOV A,[m]	Move Data Memory to ACC
Description	The contents of the specified Data Memory are copied to the Accumulator.
Operation	$ACC \leftarrow [m]$
Affected flag(s)	None
MOV A,x	Move immediate data to ACC
Description	The immediate data specified is loaded into the Accumulator.
Operation	$ACC \leftarrow x$
Affected flag(s)	None
MOV [m],A	Move ACC to Data Memory
Description	The contents of the Accumulator are copied to the specified Data Memory.
Operation	$[m] \leftarrow ACC$
Affected flag(s)	None

NOP	No operation
Description	No operation is performed. Execution continues with the next instruction.
Operation	No operation
Affected flag(s)	None
OR A,[m]	Logical OR Data Memory to ACC
Description	Data in the Accumulator and the specified Data Memory perform a bitwise logical OR operation. The result is stored in the Accumulator.
Operation	ACC ← ACC "OR" [m]
Affected flag(s)	Z
OR A,x	Logical OR immediate data to ACC
Description	Data in the Accumulator and the specified immediate data perform a bitwise logical OR operation. The result is stored in the Accumulator.
Operation	ACC ← ACC "OR" x
Affected flag(s)	Z
ORM A,[m]	Logical OR ACC to Data Memory
Description	Data in the specified Data Memory and the Accumulator perform a bitwise logical OR operation. The result is stored in the Data Memory.
Operation	[m] ← ACC "OR" [m]
Affected flag(s)	Z
RET	Return from subroutine
Description	The Program Counter is restored from the stack. Program execution continues at the restored address.
Operation	Program Counter ← Stack
Affected flag(s)	None
RET A,x	Return from subroutine and load immediate data to ACC
Description	The Program Counter is restored from the stack and the Accumulator loaded with the specified immediate data. Program execution continues at the restored address.
Operation	Program Counter ← Stack ACC ← x
Affected flag(s)	None
RETI	Return from interrupt
Description	The Program Counter is restored from the stack and the interrupts are re-enabled by setting the EMI bit. EMI is the master interrupt global enable bit. If an interrupt was pending when the RETI instruction is executed, the pending Interrupt routine will be processed before returning to the main program.
Operation	Program Counter ← Stack EMI ← 1
Affected flag(s)	None
RL [m]	Rotate Data Memory left
Description	The contents of the specified Data Memory are rotated left by 1 bit with bit 7 rotated into bit 0.
Operation	[m].(i+1) ← [m].i; (i=0~6) [m].0 ← [m].7
Affected flag(s)	None

RLA [m]	Rotate Data Memory left with result in ACC
Description	The contents of the specified Data Memory are rotated left by 1 bit with bit 7 rotated into bit 0. The rotated result is stored in the Accumulator and the contents of the Data Memory remain unchanged.
Operation	$ACC.(i+1) \leftarrow [m].i; (i=0\sim6)$ $ACC.0 \leftarrow [m].7$
Affected flag(s)	None
RLC [m]	Rotate Data Memory left through Carry
Description	The contents of the specified Data Memory and the carry flag are rotated left by 1 bit. Bit 7 replaces the Carry bit and the original carry flag is rotated into bit 0.
Operation	$[m].(i+1) \leftarrow [m].i; (i=0\sim6)$ $[m].0 \leftarrow C$ $C \leftarrow [m].7$
Affected flag(s)	C
RLCA [m]	Rotate Data Memory left through Carry with result in ACC
Description	Data in the specified Data Memory and the carry flag are rotated left by 1 bit. Bit 7 replaces the Carry bit and the original carry flag is rotated into the bit 0. The rotated result is stored in the Accumulator and the contents of the Data Memory remain unchanged.
Operation	$ACC.(i+1) \leftarrow [m].i; (i=0\sim6)$ $ACC.0 \leftarrow C$ $C \leftarrow [m].7$
Affected flag(s)	C
RR [m]	Rotate Data Memory right
Description	The contents of the specified Data Memory are rotated right by 1 bit with bit 0 rotated into bit 7.
Operation	$[m].i \leftarrow [m].(i+1); (i=0\sim6)$ $[m].7 \leftarrow [m].0$
Affected flag(s)	None
RRA [m]	Rotate Data Memory right with result in ACC
Description	Data in the specified Data Memory is rotated right by 1 bit with bit 0 rotated into bit 7. The rotated result is stored in the Accumulator and the contents of the Data Memory remain unchanged.
Operation	$ACC.i \leftarrow [m].(i+1); (i=0\sim6)$ $ACC.7 \leftarrow [m].0$
Affected flag(s)	None
RRC [m]	Rotate Data Memory right through Carry
Description	The contents of the specified Data Memory and the carry flag are rotated right by 1 bit. Bit 0 replaces the Carry bit and the original carry flag is rotated into bit 7.
Operation	$[m].i \leftarrow [m].(i+1); (i=0\sim6)$ $[m].7 \leftarrow C$ $C \leftarrow [m].0$
Affected flag(s)	C

RRCA [m]	Rotate Data Memory right through Carry with result in ACC
Description	Data in the specified Data Memory and the carry flag are rotated right by 1 bit. Bit 0 replaces the Carry bit and the original carry flag is rotated into bit 7. The rotated result is stored in the Accumulator and the contents of the Data Memory remain unchanged.
Operation	ACC.i ← [m].(i+1); (i=0~6) ACC.7 ← C C ← [m].0
Affected flag(s)	C
SBC A,[m]	Subtract Data Memory from ACC with Carry
Description	The contents of the specified Data Memory and the complement of the carry flag are subtracted from the Accumulator. The result is stored in the Accumulator. Note that if the result of subtraction is negative, the C flag will be cleared to 0, otherwise if the result is positive or zero, the C flag will be set to 1.
Operation	ACC ← ACC – [m] – \bar{C}
Affected flag(s)	OV, Z, AC, C, SC, CZ
SBC A, x	Subtract immediate data from ACC with Carry
Description	The immediate data and the complement of the carry flag are subtracted from the Accumulator. The result is stored in the Accumulator. Note that if the result of subtraction is negative, the C flag will be cleared to 0, otherwise if the result is positive or zero, the C flag will be set to 1.
Operation	ACC ← ACC – [m] – \bar{C}
Affected flag(s)	OV, Z, AC, C, SC, CZ
SBCM A,[m]	Subtract Data Memory from ACC with Carry and result in Data Memory
Description	The contents of the specified Data Memory and the complement of the carry flag are subtracted from the Accumulator. The result is stored in the Data Memory. Note that if the result of subtraction is negative, the C flag will be cleared to 0, otherwise if the result is positive or zero, the C flag will be set to 1.
Operation	[m] ← ACC – [m] – \bar{C}
Affected flag(s)	OV, Z, AC, C, SC, CZ
SDZ [m]	Skip if decrement Data Memory is 0
Description	The contents of the specified Data Memory are first decremented by 1. If the result is 0 the following instruction is skipped. As this requires the insertion of a dummy instruction while the next instruction is fetched, it is a two cycle instruction. If the result is not 0 the program proceeds with the following instruction.
Operation	[m] ← [m] – 1 Skip if [m]=0
Affected flag(s)	None
SDZA [m]	Skip if decrement Data Memory is zero with result in ACC
Description	The contents of the specified Data Memory are first decremented by 1. If the result is 0, the following instruction is skipped. The result is stored in the Accumulator but the specified Data Memory contents remain unchanged. As this requires the insertion of a dummy instruction while the next instruction is fetched, it is a two cycle instruction. If the result is not 0, the program proceeds with the following instruction.
Operation	ACC ← [m] – 1 Skip if ACC=0
Affected flag(s)	None

SET [m]	Set Data Memory
Description	Each bit of the specified Data Memory is set to 1.
Operation	$[m] \leftarrow FFH$
Affected flag(s)	None
SET [m].i	Set bit of Data Memory
Description	Bit i of the specified Data Memory is set to 1.
Operation	$[m].i \leftarrow 1$
Affected flag(s)	None
SIZ [m]	Skip if increment Data Memory is 0
Description	The contents of the specified Data Memory are first incremented by 1. If the result is 0, the following instruction is skipped. As this requires the insertion of a dummy instruction while the next instruction is fetched, it is a two cycle instruction. If the result is not 0 the program proceeds with the following instruction.
Operation	$[m] \leftarrow [m] + 1$ Skip if $[m]=0$
Affected flag(s)	None
SIZA [m]	Skip if increment Data Memory is zero with result in ACC
Description	The contents of the specified Data Memory are first incremented by 1. If the result is 0, the following instruction is skipped. The result is stored in the Accumulator but the specified Data Memory contents remain unchanged. As this requires the insertion of a dummy instruction while the next instruction is fetched, it is a two cycle instruction. If the result is not 0 the program proceeds with the following instruction.
Operation	$ACC \leftarrow [m] + 1$ Skip if $ACC=0$
Affected flag(s)	None
SNZ [m].i	Skip if bit i of Data Memory is not 0
Description	If bit i of the specified Data Memory is not 0, the following instruction is skipped. As this requires the insertion of a dummy instruction while the next instruction is fetched, it is a two cycle instruction. If the result is 0 the program proceeds with the following instruction.
Operation	Skip if $[m].i \neq 0$
Affected flag(s)	None
SNZ [m]	Skip if Data Memory is not 0
Description	The contents of the specified Data Memory are read out and then written back to the specified Data Memory again. If the specified Data Memory is not 0, the following instruction is skipped. As this requires the insertion of a dummy instruction while the next instruction is fetched, it is a two cycle instruction. If the result is 0 the program proceeds with the following instruction.
Operation	Skip if $[m] \neq 0$
Affected flag(s)	None
SUB A,[m]	Subtract Data Memory from ACC
Description	The specified Data Memory is subtracted from the contents of the Accumulator. The result is stored in the Accumulator. Note that if the result of subtraction is negative, the C flag will be cleared to 0, otherwise if the result is positive or zero, the C flag will be set to 1.
Operation	$ACC \leftarrow ACC - [m]$
Affected flag(s)	OV, Z, AC, C, SC, CZ

SUBM A,[m]	Subtract Data Memory from ACC with result in Data Memory
Description	The specified Data Memory is subtracted from the contents of the Accumulator. The result is stored in the Data Memory. Note that if the result of subtraction is negative, the C flag will be cleared to 0, otherwise if the result is positive or zero, the C flag will be set to 1.
Operation	$[m] \leftarrow ACC - [m]$
Affected flag(s)	OV, Z, AC, C, SC, CZ
SUB A,x	Subtract immediate data from ACC
Description	The immediate data specified by the code is subtracted from the contents of the Accumulator. The result is stored in the Accumulator. Note that if the result of subtraction is negative, the C flag will be cleared to 0, otherwise if the result is positive or zero, the C flag will be set to 1.
Operation	$ACC \leftarrow ACC - x$
Affected flag(s)	OV, Z, AC, C, SC, CZ
SWAP [m]	Swap nibbles of Data Memory
Description	The low-order and high-order nibbles of the specified Data Memory are interchanged.
Operation	$[m].3 \sim [m].0 \leftrightarrow [m].7 \sim [m].4$
Affected flag(s)	None
SWAPA [m]	Swap nibbles of Data Memory with result in ACC
Description	The low-order and high-order nibbles of the specified Data Memory are interchanged. The result is stored in the Accumulator. The contents of the Data Memory remain unchanged.
Operation	$ACC.3 \sim ACC.0 \leftarrow [m].7 \sim [m].4$ $ACC.7 \sim ACC.4 \leftarrow [m].3 \sim [m].0$
Affected flag(s)	None
SZ [m]	Skip if Data Memory is 0
Description	The contents of the specified Data Memory are read out and then written back to the specified Data Memory again. If the contents of the specified Data Memory is 0, the following instruction is skipped. As this requires the insertion of a dummy instruction while the next instruction is fetched, it is a two cycle instruction. If the result is not 0 the program proceeds with the following instruction.
Operation	Skip if $[m]=0$
Affected flag(s)	None
SZA [m]	Skip if Data Memory is 0 with data movement to ACC
Description	The contents of the specified Data Memory are copied to the Accumulator. If the value is zero, the following instruction is skipped. As this requires the insertion of a dummy instruction while the next instruction is fetched, it is a two cycle instruction. If the result is not 0 the program proceeds with the following instruction.
Operation	$ACC \leftarrow [m]$ Skip if $[m]=0$
Affected flag(s)	None
SZ [m].i	Skip if bit i of Data Memory is 0
Description	If bit i of the specified Data Memory is 0, the following instruction is skipped. As this requires the insertion of a dummy instruction while the next instruction is fetched, it is a two cycle instruction. If the result is not 0, the program proceeds with the following instruction.
Operation	Skip if $[m].i=0$
Affected flag(s)	None

TABRD [m]	Read table (specific page) to TBLH and Data Memory
Description	The low byte of the program code (specific page) addressed by the table pointer (TBLP and TBHP) is moved to the specified Data Memory and the high byte moved to TBLH.
Operation	[m] ← program code (low byte) TBLH ← program code (high byte)
Affected flag(s)	None
TABRDL [m]	Read table (last page) to TBLH and Data Memory
Description	The low byte of the program code (last page) addressed by the table pointer (TBLP) is moved to the specified Data Memory and the high byte moved to TBLH.
Operation	[m] ← program code (low byte) TBLH ← program code (high byte)
Affected flag(s)	None
ITABRD [m]	Increment table pointer low byte first and read table (specific page) to TBLH and Data Memory
Description	Increment table pointer low byte, TBLP, first and then the program code (specific page) addressed by the table pointer (TBHP and TBLP) is moved to the specified Data Memory and the high byte moved to TBLH.
Operation	[m] ← program code (low byte) TBLH ← program code (high byte)
Affected flag(s)	None
ITABRDL [m]	Increment table pointer low byte first and read table (last page) to TBLH and Data Memory
Description	Increment table pointer low byte, TBLP, first and then the low byte of the program code (last page) addressed by the table pointer (TBLP) is moved to the specified Data Memory and the high byte moved to TBLH.
Operation	[m] ← program code (low byte) TBLH ← program code (high byte)
Affected flag(s)	None
XOR A,[m]	Logical XOR Data Memory to ACC
Description	Data in the Accumulator and the specified Data Memory perform a bitwise logical XOR operation. The result is stored in the Accumulator.
Operation	ACC ← ACC "XOR" [m]
Affected flag(s)	Z
XORM A,[m]	Logical XOR ACC to Data Memory
Description	Data in the specified Data Memory and the Accumulator perform a bitwise logical XOR operation. The result is stored in the Data Memory.
Operation	[m] ← ACC "XOR" [m]
Affected flag(s)	Z
XOR A,x	Logical XOR immediate data to ACC
Description	Data in the Accumulator and the specified immediate data perform a bitwise logical XOR operation. The result is stored in the Accumulator.
Operation	ACC ← ACC "XOR" x
Affected flag(s)	Z

Extended Instruction Definition

The extended instructions are used to directly access the data stored in any data memory sections.

LADC A,[m]	Add Data Memory to ACC with Carry
Description	The contents of the specified Data Memory, Accumulator and the carry flag are added. The result is stored in the Accumulator.
Operation	$ACC \leftarrow ACC + [m] + C$
Affected flag(s)	OV, Z, AC, C, SC
LADCM A,[m]	Add ACC to Data Memory with Carry
Description	The contents of the specified Data Memory, Accumulator and the carry flag are added. The result is stored in the specified Data Memory.
Operation	$[m] \leftarrow ACC + [m] + C$
Affected flag(s)	OV, Z, AC, C, SC
LADD A,[m]	Add Data Memory to ACC
Description	The contents of the specified Data Memory and the Accumulator are added. The result is stored in the Accumulator.
Operation	$ACC \leftarrow ACC + [m]$
Affected flag(s)	OV, Z, AC, C, SC
LADDM A,[m]	Add ACC to Data Memory
Description	The contents of the specified Data Memory and the Accumulator are added. The result is stored in the specified Data Memory.
Operation	$[m] \leftarrow ACC + [m]$
Affected flag(s)	OV, Z, AC, C, SC
LAND A,[m]	Logical AND Data Memory to ACC
Description	Data in the Accumulator and the specified Data Memory perform a bitwise logical AND operation. The result is stored in the Accumulator.
Operation	$ACC \leftarrow ACC \text{ "AND" } [m]$
Affected flag(s)	Z
LANDM A,[m]	Logical AND ACC to Data Memory
Description	Data in the specified Data Memory and the Accumulator perform a bitwise logical AND operation. The result is stored in the Data Memory.
Operation	$[m] \leftarrow ACC \text{ "AND" } [m]$
Affected flag(s)	Z
LCLR [m]	Clear Data Memory
Description	Each bit of the specified Data Memory is cleared to 0.
Operation	$[m] \leftarrow 00H$
Affected flag(s)	None
LCLR [m].i	Clear bit of Data Memory
Description	Bit i of the specified Data Memory is cleared to 0.
Operation	$[m].i \leftarrow 0$
Affected flag(s)	None

LCPL [m]	Complement Data Memory
Description	Each bit of the specified Data Memory is logically complemented (1's complement). Bits which previously contained a 1 are changed to 0 and vice versa.
Operation	$[m] \leftarrow \overline{[m]}$
Affected flag(s)	Z
LCPLA [m]	Complement Data Memory with result in ACC
Description	Each bit of the specified Data Memory is logically complemented (1's complement). Bits which previously contained a 1 are changed to 0 and vice versa. The complemented result is stored in the Accumulator and the contents of the Data Memory remain unchanged.
Operation	$ACC \leftarrow \overline{[m]}$
Affected flag(s)	Z
LDAA [m]	Decimal-Adjust ACC for addition with result in Data Memory
Description	Convert the contents of the Accumulator value to a BCD (Binary Coded Decimal) value resulting from the previous addition of two BCD variables. If the low nibble is greater than 9 or if AC flag is set, then a value of 6 will be added to the low nibble. Otherwise the low nibble remains unchanged. If the high nibble is greater than 9 or if the C flag is set, then a value of 6 will be added to the high nibble. Essentially, the decimal conversion is performed by adding 00H, 06H, 60H or 66H depending on the Accumulator and flag conditions. Only the C flag may be affected by this instruction which indicates that if the original BCD sum is greater than 100, it allows multiple precision decimal addition.
Operation	$[m] \leftarrow ACC + 00H$ or $[m] \leftarrow ACC + 06H$ or $[m] \leftarrow ACC + 60H$ or $[m] \leftarrow ACC + 66H$
Affected flag(s)	C
LDEC [m]	Decrement Data Memory
Description	Data in the specified Data Memory is decremented by 1.
Operation	$[m] \leftarrow [m] - 1$
Affected flag(s)	Z
LDECA [m]	Decrement Data Memory with result in ACC
Description	Data in the specified Data Memory is decremented by 1. The result is stored in the Accumulator. The contents of the Data Memory remain unchanged.
Operation	$ACC \leftarrow [m] - 1$
Affected flag(s)	Z
LINC [m]	Increment Data Memory
Description	Data in the specified Data Memory is incremented by 1.
Operation	$[m] \leftarrow [m] + 1$
Affected flag(s)	Z
LINCA [m]	Increment Data Memory with result in ACC
Description	Data in the specified Data Memory is incremented by 1. The result is stored in the Accumulator. The contents of the Data Memory remain unchanged.
Operation	$ACC \leftarrow [m] + 1$
Affected flag(s)	Z

LMOV A,[m]	Move Data Memory to ACC
Description	The contents of the specified Data Memory are copied to the Accumulator.
Operation	$ACC \leftarrow [m]$
Affected flag(s)	None
LMOV [m],A	Move ACC to Data Memory
Description	The contents of the Accumulator are copied to the specified Data Memory.
Operation	$[m] \leftarrow ACC$
Affected flag(s)	None
LOR A,[m]	Logical OR Data Memory to ACC
Description	Data in the Accumulator and the specified Data Memory perform a bitwise logical OR operation. The result is stored in the Accumulator.
Operation	$ACC \leftarrow ACC \text{ "OR" } [m]$
Affected flag(s)	Z
LORM A,[m]	Logical OR ACC to Data Memory
Description	Data in the specified Data Memory and the Accumulator perform a bitwise logical OR operation. The result is stored in the Data Memory.
Operation	$[m] \leftarrow ACC \text{ "OR" } [m]$
Affected flag(s)	Z
LRL [m]	Rotate Data Memory left
Description	The contents of the specified Data Memory are rotated left by 1 bit with bit 7 rotated into bit 0.
Operation	$[m].(i+1) \leftarrow [m].i; (i=0\sim 6)$ $[m].0 \leftarrow [m].7$
Affected flag(s)	None
LRLA [m]	Rotate Data Memory left with result in ACC
Description	The contents of the specified Data Memory are rotated left by 1 bit with bit 7 rotated into bit 0. The rotated result is stored in the Accumulator and the contents of the Data Memory remain unchanged.
Operation	$ACC.(i+1) \leftarrow [m].i; (i=0\sim 6)$ $ACC.0 \leftarrow [m].7$
Affected flag(s)	None
LRLC [m]	Rotate Data Memory left through Carry
Description	The contents of the specified Data Memory and the carry flag are rotated left by 1 bit. Bit 7 replaces the Carry bit and the original carry flag is rotated into bit 0.
Operation	$[m].(i+1) \leftarrow [m].i; (i=0\sim 6)$ $[m].0 \leftarrow C$ $C \leftarrow [m].7$
Affected flag(s)	C
LRLCA [m]	Rotate Data Memory left through Carry with result in ACC
Description	Data in the specified Data Memory and the carry flag are rotated left by 1 bit. Bit 7 replaces the Carry bit and the original carry flag is rotated into the bit 0. The rotated result is stored in the Accumulator and the contents of the Data Memory remain unchanged.
Operation	$ACC.(i+1) \leftarrow [m].i; (i=0\sim 6)$ $ACC.0 \leftarrow C$ $C \leftarrow [m].7$
Affected flag(s)	C

LRR [m]	Rotate Data Memory right
Description	The contents of the specified Data Memory are rotated right by 1 bit with bit 0 rotated into bit 7.
Operation	$[m].i \leftarrow [m].(i+1); (i=0\sim 6)$ $[m].7 \leftarrow [m].0$
Affected flag(s)	None
LRRRA [m]	Rotate Data Memory right with result in ACC
Description	Data in the specified Data Memory is rotated right by 1 bit with bit 0 rotated into bit 7. The rotated result is stored in the Accumulator and the contents of the Data Memory remain unchanged.
Operation	$ACC.i \leftarrow [m].(i+1); (i=0\sim 6)$ $ACC.7 \leftarrow [m].0$
Affected flag(s)	None
LRRRC [m]	Rotate Data Memory right through Carry
Description	The contents of the specified Data Memory and the carry flag are rotated right by 1 bit. Bit 0 replaces the Carry bit and the original carry flag is rotated into bit 7.
Operation	$[m].i \leftarrow [m].(i+1); (i=0\sim 6)$ $[m].7 \leftarrow C$ $C \leftarrow [m].0$
Affected flag(s)	C
LRRCA [m]	Rotate Data Memory right through Carry with result in ACC
Description	Data in the specified Data Memory and the carry flag are rotated right by 1 bit. Bit 0 replaces the Carry bit and the original carry flag is rotated into bit 7. The rotated result is stored in the Accumulator and the contents of the Data Memory remain unchanged.
Operation	$ACC.i \leftarrow [m].(i+1); (i=0\sim 6)$ $ACC.7 \leftarrow C$ $C \leftarrow [m].0$
Affected flag(s)	C
LSBC A,[m]	Subtract Data Memory from ACC with Carry
Description	The contents of the specified Data Memory and the complement of the carry flag are subtracted from the Accumulator. The result is stored in the Accumulator. Note that if the result of subtraction is negative, the C flag will be cleared to 0, otherwise if the result is positive or zero, the C flag will be set to 1.
Operation	$ACC \leftarrow ACC - [m] - \bar{C}$
Affected flag(s)	OV, Z, AC, C, SC, CZ
LSBCM A,[m]	Subtract Data Memory from ACC with Carry and result in Data Memory
Description	The contents of the specified Data Memory and the complement of the carry flag are subtracted from the Accumulator. The result is stored in the Data Memory. Note that if the result of subtraction is negative, the C flag will be cleared to 0, otherwise if the result is positive or zero, the C flag will be set to 1.
Operation	$[m] \leftarrow ACC - [m] - \bar{C}$
Affected flag(s)	OV, Z, AC, C, SC, CZ

LSDZ [m]	Skip if decrement Data Memory is 0
Description	The contents of the specified Data Memory are first decremented by 1. If the result is 0 the following instruction is skipped. As this requires the insertion of a dummy instruction while the next instruction is fetched, it is a three cycle instruction. If the result is not 0 the program proceeds with the following instruction.
Operation	$[m] \leftarrow [m] - 1$ Skip if $[m]=0$
Affected flag(s)	None
LSDZA [m]	Skip if decrement Data Memory is zero with result in ACC
Description	The contents of the specified Data Memory are first decremented by 1. If the result is 0, the following instruction is skipped. The result is stored in the Accumulator but the specified Data Memory contents remain unchanged. As this requires the insertion of a dummy instruction while the next instruction is fetched, it is a three cycle instruction. If the result is not 0, the program proceeds with the following instruction.
Operation	$ACC \leftarrow [m] - 1$ Skip if $ACC=0$
Affected flag(s)	None
LSET [m]	Set Data Memory
Description	Each bit of the specified Data Memory is set to 1.
Operation	$[m] \leftarrow FFH$
Affected flag(s)	None
LSET [m].i	Set bit of Data Memory
Description	Bit i of the specified Data Memory is set to 1.
Operation	$[m].i \leftarrow 1$
Affected flag(s)	None
LSIZ [m]	Skip if increment Data Memory is 0
Description	The contents of the specified Data Memory are first incremented by 1. If the result is 0, the following instruction is skipped. As this requires the insertion of a dummy instruction while the next instruction is fetched, it is a three cycle instruction. If the result is not 0 the program proceeds with the following instruction.
Operation	$[m] \leftarrow [m] + 1$ Skip if $[m]=0$
Affected flag(s)	None
LSIZA [m]	Skip if increment Data Memory is zero with result in ACC
Description	The contents of the specified Data Memory are first incremented by 1. If the result is 0, the following instruction is skipped. The result is stored in the Accumulator but the specified Data Memory contents remain unchanged. As this requires the insertion of a dummy instruction while the next instruction is fetched, it is a three cycle instruction. If the result is not 0 the program proceeds with the following instruction.
Operation	$ACC \leftarrow [m] + 1$ Skip if $ACC=0$
Affected flag(s)	None
LSNZ [m].i	Skip if bit i of Data Memory is not 0
Description	If bit i of the specified Data Memory is not 0, the following instruction is skipped. As this requires the insertion of a dummy instruction while the next instruction is fetched, it is a three cycle instruction. If the result is 0 the program proceeds with the following instruction.
Operation	Skip if $[m].i \neq 0$
Affected flag(s)	None

LSNZ [m]	Skip if Data Memory is not 0
Description	The contents of the specified Data Memory are read out and then written to the specified Data Memory again. If the content of the specified Data Memory is not 0, the following instruction is skipped. As this requires the insertion of a dummy instruction while the next instruction is fetched, it is a three cycle instruction. If the result is 0 the program proceeds with the following instruction.
Operation	Skip if [m] ≠ 0
Affected flag(s)	None
LSUB A,[m]	Subtract Data Memory from ACC
Description	The specified Data Memory is subtracted from the contents of the Accumulator. The result is stored in the Accumulator. Note that if the result of subtraction is negative, the C flag will be cleared to 0, otherwise if the result is positive or zero, the C flag will be set to 1.
Operation	$ACC \leftarrow ACC - [m]$
Affected flag(s)	OV, Z, AC, C, SC, CZ
LSUBM A,[m]	Subtract Data Memory from ACC with result in Data Memory
Description	The specified Data Memory is subtracted from the contents of the Accumulator. The result is stored in the Data Memory. Note that if the result of subtraction is negative, the C flag will be cleared to 0, otherwise if the result is positive or zero, the C flag will be set to 1.
Operation	$[m] \leftarrow ACC - [m]$
Affected flag(s)	OV, Z, AC, C, SC, CZ
LSWAP [m]	Swap nibbles of Data Memory
Description	The low-order and high-order nibbles of the specified Data Memory are interchanged.
Operation	$[m].3 \sim [m].0 \leftrightarrow [m].7 \sim [m].4$
Affected flag(s)	None
LSWAPA [m]	Swap nibbles of Data Memory with result in ACC
Description	The low-order and high-order nibbles of the specified Data Memory are interchanged. The result is stored in the Accumulator. The contents of the Data Memory remain unchanged.
Operation	$ACC.3 \sim ACC.0 \leftarrow [m].7 \sim [m].4$ $ACC.7 \sim ACC.4 \leftarrow [m].3 \sim [m].0$
Affected flag(s)	None
LSZ [m]	Skip if Data Memory is 0
Description	The contents of the specified Data Memory are read out and then written to the specified Data Memory again. If the contents of the specified Data Memory is 0, the following instruction is skipped. As this requires the insertion of a dummy instruction while the next instruction is fetched, it is a three cycle instruction. If the result is not 0 the program proceeds with the following instruction.
Operation	Skip if [m]=0
Affected flag(s)	None
LSZA [m]	Skip if Data Memory is 0 with data movement to ACC
Description	The contents of the specified Data Memory are copied to the Accumulator. If the value is zero, the following instruction is skipped. As this requires the insertion of a dummy instruction while the next instruction is fetched, it is a three cycle instruction. If the result is not 0 the program proceeds with the following instruction.
Operation	$ACC \leftarrow [m]$ Skip if [m]=0
Affected flag(s)	None

LSZ [m].i	Skip if bit i of Data Memory is 0
Description	If bit i of the specified Data Memory is 0, the following instruction is skipped. As this requires the insertion of a dummy instruction while the next instruction is fetched, it is a three cycle instruction. If the result is not 0, the program proceeds with the following instruction.
Operation	Skip if [m].i=0
Affected flag(s)	None
LTABRD [m]	Read table (specific page) to TBLH and Data Memory
Description	The low byte of the program code (specific page) addressed by the table pointer (TBHP and TBLP) is moved to the specified Data Memory and the high byte moved to TBLH.
Operation	[m] ← program code (low byte) TBLH ← program code (high byte)
Affected flag(s)	None
LTABRDL [m]	Read table (last page) to TBLH and Data Memory
Description	The low byte of the program code (last page) addressed by the table pointer (TBLP) is moved to the specified Data Memory and the high byte moved to TBLH.
Operation	[m] ← program code (low byte) TBLH ← program code (high byte)
Affected flag(s)	None
LITABRD [m]	Increment table pointer low byte first and read table (specific page) to TBLH and Data Memory
Description	Increment table pointer low byte, TBLP, first and then the program code (specific page) addressed by the table pointer (TBHP and TBLP) is moved to the specified Data Memory and the high byte moved to TBLH.
Operation	[m] ← program code (low byte) TBLH ← program code (high byte)
Affected flag(s)	None
LITABRDL [m]	Increment table pointer low byte first and read table (last page) to TBLH and Data Memory
Description	Increment table pointer low byte, TBLP, first and then the low byte of the program code (last page) addressed by the table pointer (TBLP) is moved to the specified Data Memory and the high byte moved to TBLH.
Operation	[m] ← program code (low byte) TBLH ← program code (high byte)
Affected flag(s)	None
LXOR A,[m]	Logical XOR Data Memory to ACC
Description	Data in the Accumulator and the specified Data Memory perform a bitwise logical XOR operation. The result is stored in the Accumulator.
Operation	ACC ← ACC "XOR" [m]
Affected flag(s)	Z
LXORM A,[m]	Logical XOR ACC to Data Memory
Description	Data in the specified Data Memory and the Accumulator perform a bitwise logical XOR operation. The result is stored in the Data Memory.
Operation	[m] ← ACC "XOR" [m]
Affected flag(s)	Z

Package Information

Note that the package information provided here is for consultation purposes only. As this information may be updated at regular intervals users are reminded to consult the [Holtek website](#) for the latest version of the [Package/Carton Information](#).

Additional supplementary information with regard to packaging is listed below. Click on the relevant section to be transferred to the relevant website page.

- [Package Information \(include Outline Dimensions, Product Tape and Reel Specifications\)](#)
- [The Operation Instruction of Packing Materials](#)
- [Carton information](#)

48-pin LQFP (7mm×7mm) Outline Dimensions

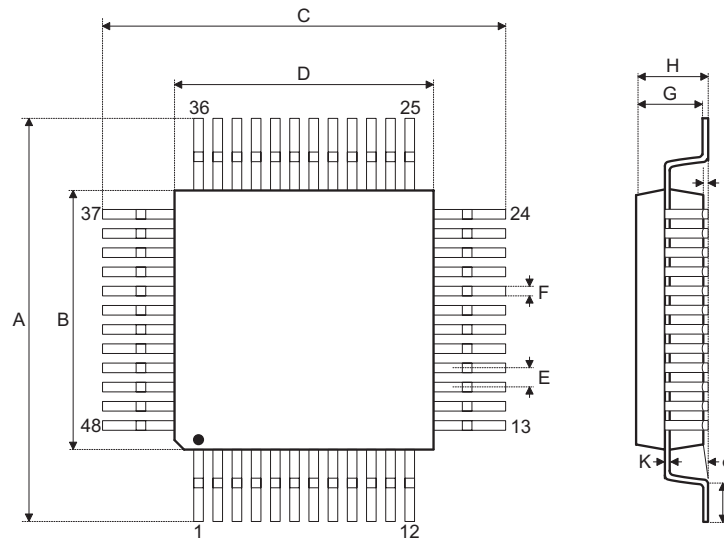

Symbol	Dimensions in inch		
	Min.	Nom.	Max.
A	0.354 BSC		
B	0.276 BSC		
C	0.354 BSC		
D	0.276 BSC		
E	0.020 BSC		
F	0.007	0.009	0.011
G	0.053	0.055	0.057
H	—	—	0.063
I	0.002	—	0.006
J	0.018	0.024	0.030
K	0.004	—	0.008
α	0°	—	7°

Symbol	Dimensions in mm		
	Min.	Nom.	Max.
A	9.00 BSC		
B	7.00 BSC		
C	9.00 BSC		
D	7.00 BSC		
E	0.50 BSC		
F	0.17	0.22	0.27
G	1.35	1.40	1.45
H	—	—	1.60
I	0.05	—	0.15
J	0.45	0.60	0.75
K	0.09	—	0.20
α	0°	—	7°

Copyright© 2023 by HOLTEK SEMICONDUCTOR INC. All Rights Reserved.

The information provided in this document has been produced with reasonable care and attention before publication, however, HOLTEK does not guarantee that the information is completely accurate. The information contained in this publication is provided for reference only and may be superseded by updates. HOLTEK disclaims any expressed, implied or statutory warranties, including but not limited to suitability for commercialization, satisfactory quality, specifications, characteristics, functions, fitness for a particular purpose, and non-infringement of any third-party's rights. HOLTEK disclaims all liability arising from the information and its application. In addition, HOLTEK does not recommend the use of HOLTEK's products where there is a risk of personal hazard due to malfunction or other reasons. HOLTEK hereby declares that it does not authorize the use of these products in life-saving, life-sustaining or safety critical components. Any use of HOLTEK's products in life-saving/sustaining or safety applications is entirely at the buyer's risk, and the buyer agrees to defend, indemnify and hold HOLTEK harmless from any damages, claims, suits, or expenses resulting from such use. The information provided in this document, including but not limited to the content, data, examples, materials, graphs, and trademarks, is the intellectual property of HOLTEK (and its licensors, where applicable) and is protected by copyright law and other intellectual property laws. No license, express or implied, to any intellectual property right, is granted by HOLTEK herein. HOLTEK reserves the right to revise the information described in the document at any time without prior notice. For the latest information, please contact us.