

HSF



NOTE:

Type:Surface Mounted Device  
 Base Material:Nylon Resin,Black Color  
 Contacts:0.35Phosphor Bronze Flash Gold  
 Flammability Rating:UL 94 V-0  
 Dielectric Strength: 560 Voits/M11,at 25°C  
 For 5 Sec

△△BBC - M - GO - A - 18650-3  
 ① ② ③ ④ ⑤

- ① BBC: Battery Holder △△
- ② Apperance For The Product
- M: SMT TYPE
- ③ Contact Plating
 

SI: NICKEL Plated	G2: 5U" Gold
SN: Tin	G3: 10U" Gold
GO: Gold Flash	G4: 15U" Gold
G1: 3U" Gold	G5: 30U" Gold
- ④ Packing Method
  - A: Tray
  - B: BAG
- ⑤ Product Number  
18650-3

PCB LAYOUT

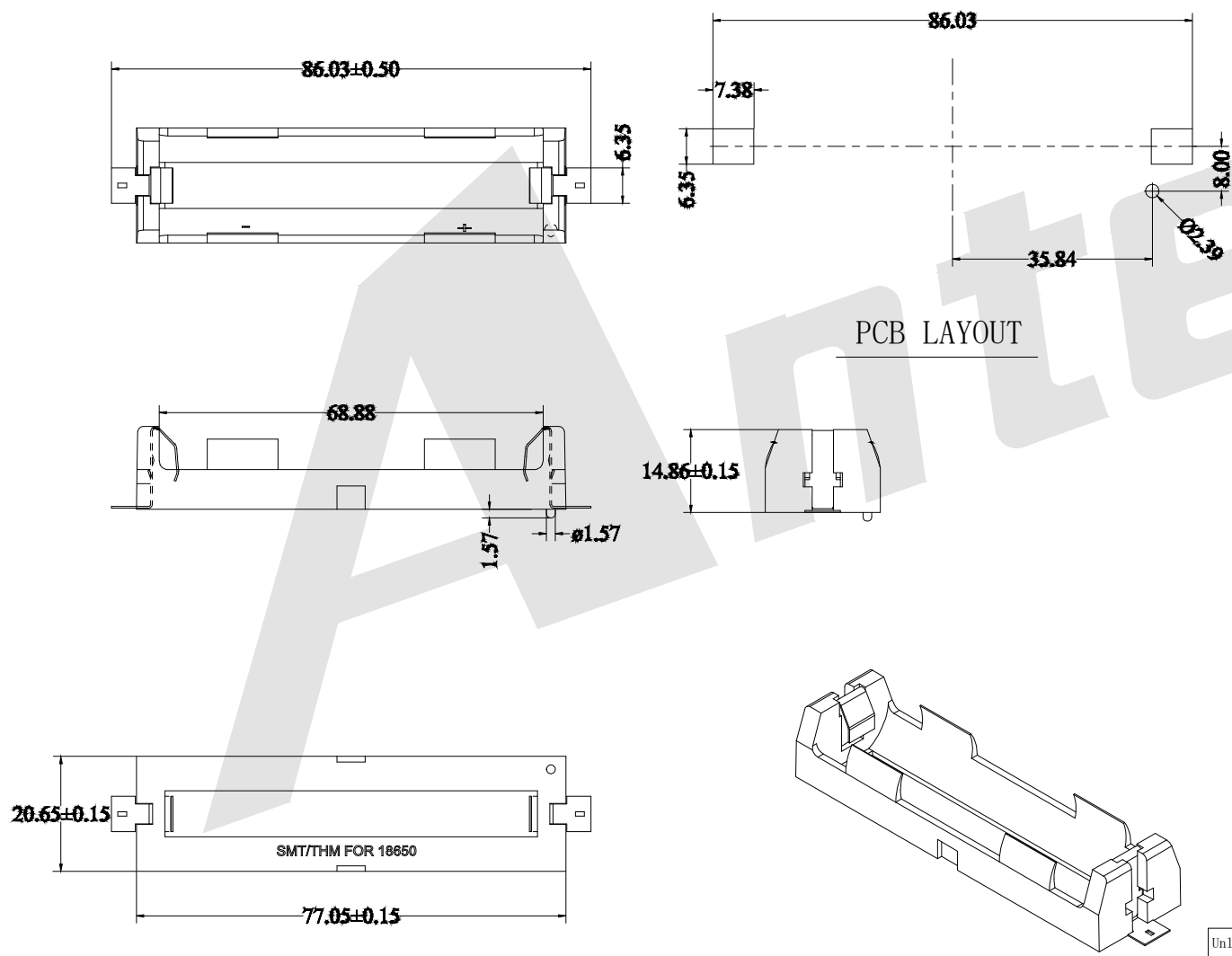

Unless Otherwise specified tolerance  
 X. ±0.35 X.XX: ±0.20  
 X.X: ±0.25 X.XXX: ±0.15

**Antenk**® ANTENK ELECTRONICS CO.,LTD  
 Http://www.antenk.com  
 E-mail:sales@antenk.com

SCALE: As Shown	UNIT: mm
DRAW Wu Feng Rong	DATE 12/07/2020
CHECK BobYang	DATE 12/07/2020

TITLE:  
△△ Battery Holder SMT For 18650-3

△△	Change BT to BBC,Revise Tittle	12/14/2022
REV	DESCRIPTION	DATE



DRAWING NO: △△BBC-M-GO-A-18650-3  
 PRODUCT NO: BBC-M-GO-A-18650-3