

Click to  
**ORDER**  
samples

## AMEOFL3-277HANZ

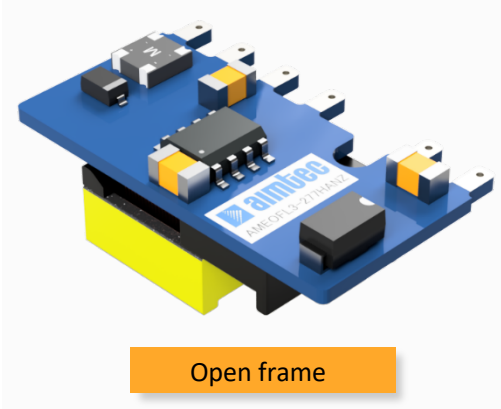

Open frame

The AMEOFL3-277HANZ series is one of Aimtec's highly efficient, green 3W AC-DC converter series. It features an ultra-wide input range accepting either AC or DC voltage, high efficiency, compact size in an open-frame, low power consumption and CLASS II reinforced insulation. A variety of EMC external circuits enable this series to meet the needs of multiple industries.

This 3W converter offers great operating temperatures, from -40°C to 85°C and also boasts an isolation of 3000VAC for improved reliability and system safety. Furthermore, a high MTBF of 1000,000h, output short circuit protection (OSCP) and an output over-current protection (OCP) come standard with the series.

All models are suitable for industrial control, electric power, instrumentation and smart home applications.

## Features



- Universal Input: 85 - 305VAC/70 - 430VDC
- Operating Temp: -40 °C to +85 °C
- High isolation voltage: 3000VAC
- Low ripple & noise, 150mV(p-p), max.
- Output short circuit, over-current
- Open frame package

## Summary

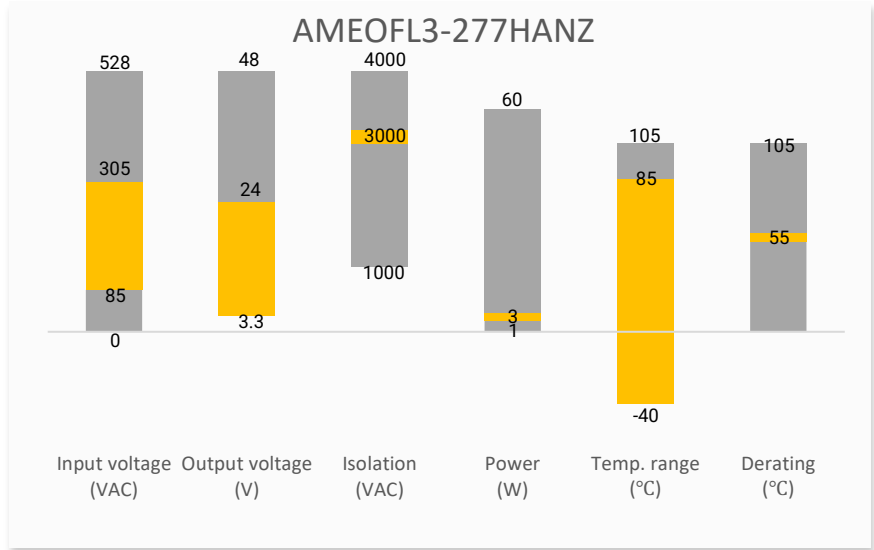

## Training

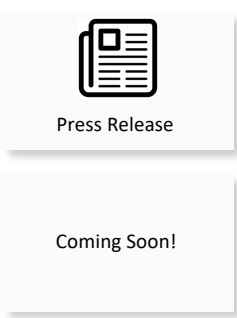
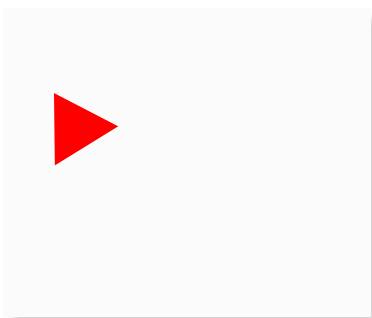

Product Training Video  
(click to open)

Application Notes

## Applications



Power Grid



Industrial



Telecom



Instrumentation

## Models & Specifications

Single Output							
Model	Input Voltage (VAC/Hz)	Input Voltage (VDC)	Max Output wattage (W)	Output Voltage (V)	Output Current max (A)	Maximum capacitive load (μF)	Efficiency @ 230VAC (%)
AMEOFL3-3S277HANZ	85~305/47~63	70~430	1.98	3.3	0.6	820	67
AMEOFL3-5S277HANZ	85~305/47~63	70~430	3	5	0.6	680	72
AMEOFL3-9S277HANZ	85~305/47~63	70~430	3	9	0.333	470	76
AMEOFL3-12S277HANZ	85~305/47~63	70~430	3	12	0.25	470	77
AMEOFL3-15S277HANZ	85~305/47~63	70~430	3	15	0.2	330	78
AMEOFL3-24S277HANZ	85~305/47~63	70~430	3	24	0.125	200	80

Input Specifications				
Parameters	Conditions	Typical	Maximum	Units
Input Current	115VAC		120	mA
	230VAC		60	
Inrush current	115VAC	13		A
	230VAC	23		
External fuse	Slow blow type	1		A

Output Specifications				
Parameters	Conditions	Typical	Maximum	Units
Voltage accuracy	10% - 100% load	± 5		%
Line regulation	Full load	± 1.5		%
Load regulation	10% - 100% load	± 3		%
Ripple & Noise	20MHz bandwidth, 10% - 100% load	80	150	mV p-p

NOTE: The output minimum load is 10%

Isolation Specifications				
Parameters	Conditions	Typical	Rated	Units
Tested I/O voltage	60 sec, 5mA max		3000	VAC

General Specifications				
Parameters	Conditions	Typical	Maximum	Units
Switching frequency		55		Khz
Safety class		Class II		
Over Current protection	Auto recovery	≥ 110		% of Iout
Short circuit protection		Hiccup, Continuous, Auto recovery		
Power consumption	230VAC	0.1	0.15	W
	+55 °C to +85 °C	1.67		% / °C
	85VAC ~ 100VAC	1.33		% /VAC
277VAC ~ 305VAC	1			
Operating temperature		-40 to +85		°C

Storage temperature	-40 to +105		°C
Temperature coefficient		±0.15	% / °C
Cooling	Free air convection		
Storage Humidity		95	% RH
Weight		3.5	g
Dimensions (L x W x H)	1.04 x 0.50 x 0.47 inches ( 26.40 x 12.58 x 12.00 mm )		
MTBF	> 1 000 000 hrs (MIL-HDBK -217F, t=+25°C)/Full Load		
NOTE: All specifications in this datasheet are measured at an ambient temperature of 25°C, humidity<75%, nominal input voltage and at rated output load unless otherwise specified.			

Safety Specifications	
Parameters	
Agency approvals	UL 62368-1
	Design to meet IEC/EN60335, IEC/EN61558, IEC/EN/UL62368
EMC - Conducted and radiated emission	CISPR32 / EN55032, Class A (With EMI class A recommended circuit) CISPR32 / EN55032, Class B (With EMI class B recommended circuit)
Electrostatic Discharge Immunity	IEC 6300-4-2 Contact ±6KV, Criteria B
RF, Electromagnetic Field Immunity	IEC 6300-4-3 10V/m, Criteria A
Electrical Fast Transient/Burst Immunity	IEC 6300-4-4 ±2KV, Criteria B (With EMS Class III recommended circuit) IEC 6300-4-4 ±4KV, Criteria B (With EMS Class IV recommended circuit)
Surge Immunity	IEC 6300-4-5 L-L ±1KV, Criteria B (With EMS Class III recommended circuit) IEC 6300-4-5 L-L ±2KV, Criteria B (With EMS Class IV recommended circuit)
RF, Conducted Disturbance Immunity	IEC 6300-4-6 10Vr.m.s, Criteria A
Voltage dips, Short Interruptions Immunity	IEC 6300-4-11 0%, 70%, Criteria B

## Derating



Temperature Derating

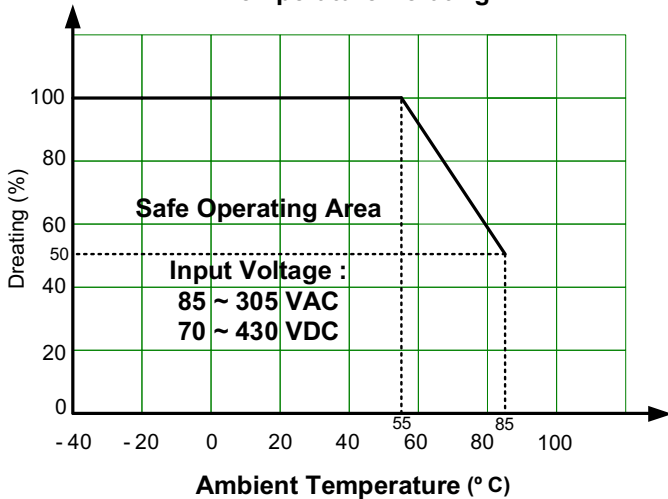

Input Voltage Derating

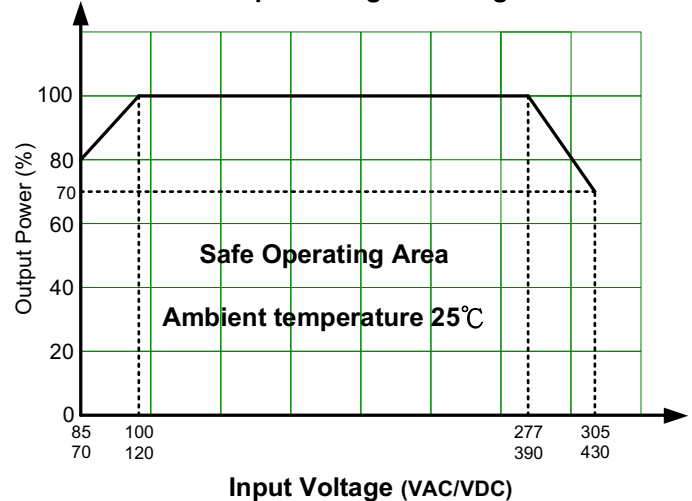

## Dimensions

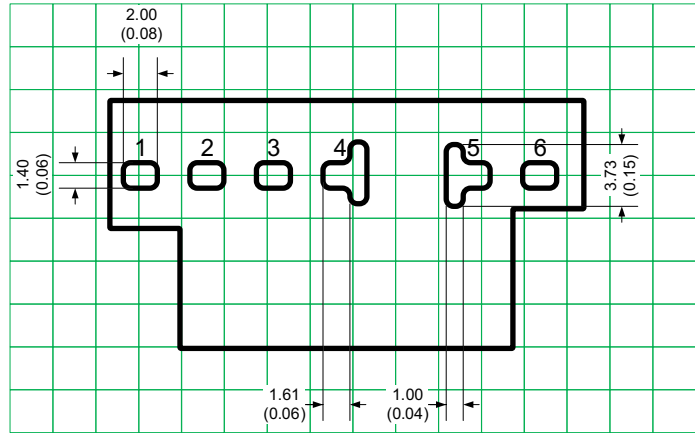
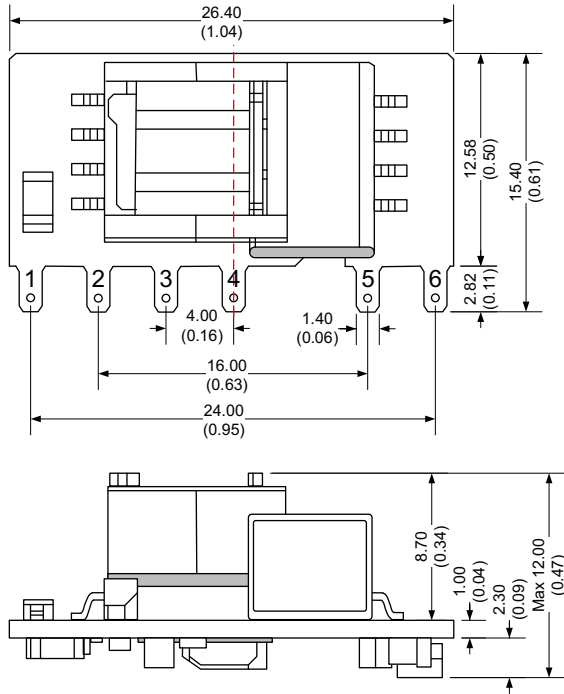

Note : Grid 2.54\*2.54 mm

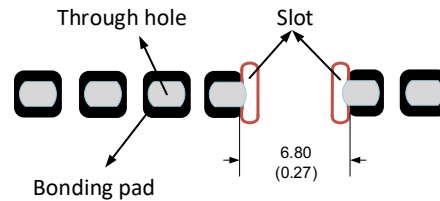

**Note:**  
 Unit: mm [inch]  
 General tolerances:  $\pm 1.00$  [ $\pm 0.040$ ]

### Pin Output Specifications

Pin	Function
1	+V Input (L)
2	-V Input (N)
3	+V_Cap
4	-V_Cap
5	-V Output
6	+V Output

1. It is necessary to add C1 between pin3 to pin4
2. It is necessary to add circuit to the output as shown in recommended circuit
3. The layout of the device is for reference only, please refer to the actual product
4. The slots between pin 4 and pin 5 are required for creepage distance consideration.

## Recommended EMC external circuit

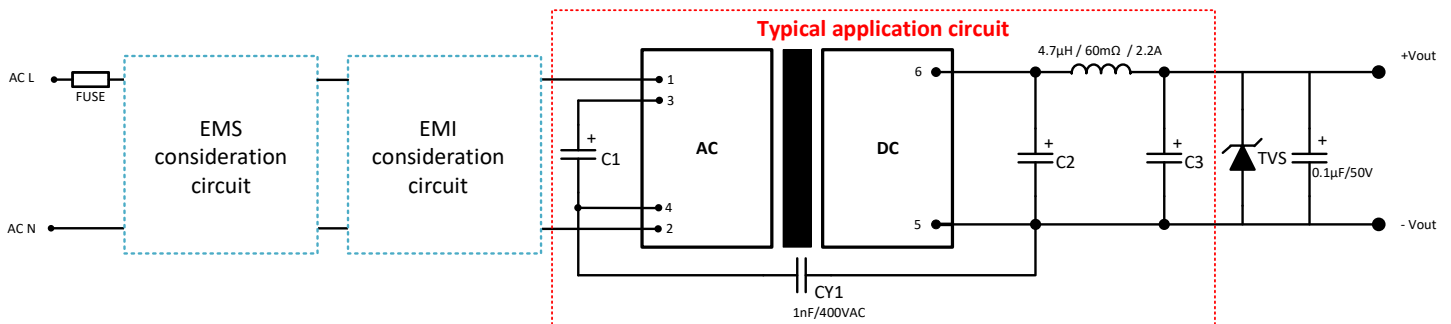

- With the variable combination of below EMS and EMI circuits which offer the different level of protection.
- The components are the must for typical application circuit in red framed area.
- A suppressor diode (TVS) is recommended to protect the application in case of a converter failure and specification should be 1.2 times of the output voltage.

### EMI & EMS Recommended Circuit

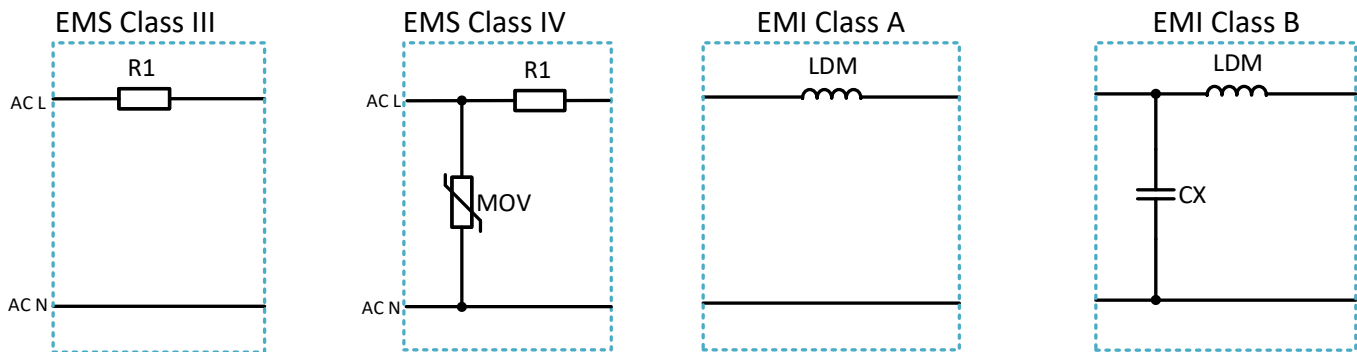

Component	EMS		EMI	
	Class III	Class IV	CLASS A	CLASS B
MOV	-	S14K350	-	-
R1	12Ω/3W	12Ω/2W	-	-
CX	-	-	-	0.1μF/310VAC
LDM	-	-	1.2mH / <4Ω / >0.2A	1.2mH / <4Ω / >0.2A
FUSE	1A/300V slow blow	2A/300V slow blow	-	-

Model name	C1	C2	C3	TVS
AMEOFL3-3S277NZ	10μF/450V	470μF/6.3V solid-state capacitor	150μF/35V	7V
AMEOFL3-5S277NZ	(-25 °C ~ +85 °C, 85 – 305VAC input; -40 °C ~ +85 °C, 165 – 305VAC input)	270μF/16V solid-state capacitor	150μF/35V	7V
AMEOFL3-9S277NZ		270μF/16V solid-state capacitor	47μF/35V	12V
AMEOFL3-12S277NZ	22μF/450V (-40 °C ~ +85 °C, 85 – 305VAC input)	270μF/16V solid-state capacitor	47μF/35V	20V
AMEOFL3-15S277NZ		220μF/35V	47μF/35V	20V
AMEOFL3-24S277NZ		220μF/35V	47μF/35V	30V

**NOTE:** 1. Datasheets are updated as needed and as such, specifications are subject to change without notice. Once printed or downloaded, datasheets are no longer controlled by Aimtec; refer to [www.aimtec.com](http://www.aimtec.com) for the most current product specifications. 2. Product labels shown, including safety agency certifications on labels, may vary based on the date manufactured. 3. Mechanical drawings and specifications are for reference only. 4. All specifications are measured at an ambient temperature of 25°C, humidity<75%, nominal input voltage and at rated output load unless otherwise specified. 5. Aimtec may not have conducted destructive testing or chemical analysis on all internal components and chemicals at the time of publishing this document. CAS numbers and other limited information are considered proprietary and may not be available for release. 6. This product is not designed for use in critical life support systems, equipment used in hazardous environments, nuclear control systems or other such applications which necessitate specific safety and regulatory standards other the ones listed in this datasheet. 7. Warranty is in accordance with Aimtec's standard Terms of Sale available at [www.aimtec.com](http://www.aimtec.com).