

Click to
ORDER
samples

AM1LS-JZ

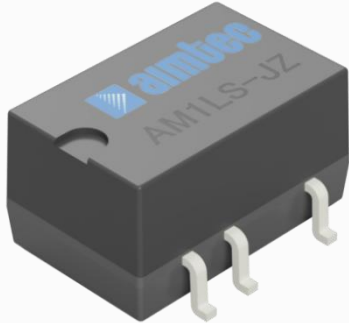

SMD Package

The AM1LS-JZ is a 1W SMD DC/DC converter that offers great cost savings thanks to an improved manufacturing process. It also features excellent reliability and performance while offering a standard input voltage range of 5-24VDC as well as an output voltage of 3.3-24V. This compact SMD design will surely benefit your new system design.

This new series offers great operating temperatures, from -40 to 105°C with full power up to 100°C. Also, an isolation of 1500VDC & 3000VDC for improved reliability and system safety as well as a great 3,500,000h MTBF come standard.

The AM1LS-JZ is suitable for instrumentation, industrial controls, communication and IoT applications.

Features

- High I/O Isolation 1500VDC & 3000VDC
- Continuous Short circuit protection
- Operating Temp: -40 °C to +105 °C
- Low profile case height: 7.25mm
- Compact footprint and high-power Density
- Efficiency up to 85%
- Unregulated output



Summary

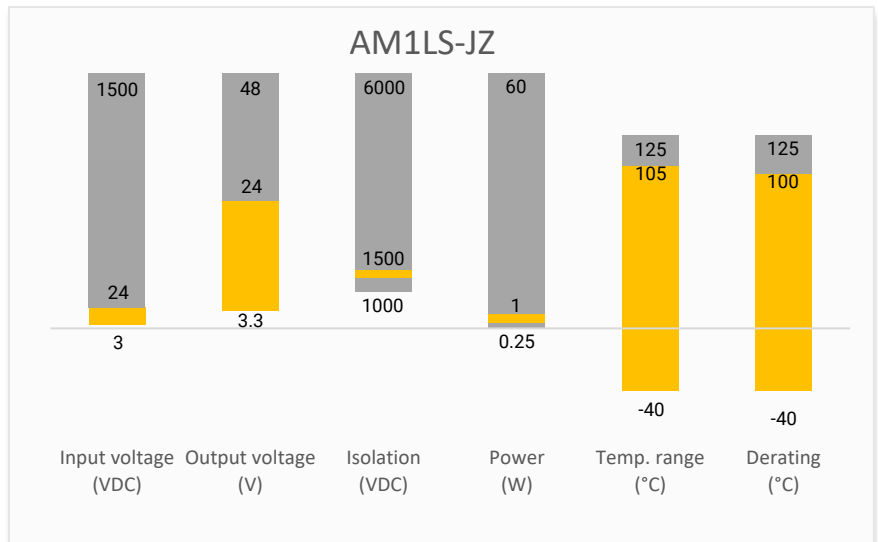

Training



Product Training Video
(click to open)



Press Release

Coming Soon!

Application Notes

Applications



IoT



Industrial



Telecom



Portable Equipment

Models & Specifications



Single Output							
Model	Input Voltage (VDC)	Output Voltage (VDC)	Input Current Full No load max (mA)	Output Current max min (mA)	Isolation (VDC)	Maximum capacitive Load (μF)	Efficiency Typ. (%)
AM1LS-0503SJZ	5 (4.5-5.5)	3.3	286 / 10	303 / 30	1500	2400	74
AM1LS-0505SJZ	5 (4.5-5.5)	5	286 / 10	200 / 20	1500	2400	82
AM1LS-0509SJZ	5 (4.5-5.5)	9	254 / 20	111 / 12	1500	1000	83
AM1LS-0512SJZ	5 (4.5-5.5)	12	254 / 20	84 / 9	1500	560	83
AM1LS-0515SJZ	5 (4.5-5.5)	15	254 / 30	67 / 7	1500	560	83
AM1LS-0524SJZ	5 (4.5-5.5)	24	254 / 30	42 / 4	1500	220	85
AM1LS-1205SJZ	12 (10.8-13.2)	5	107 / -	200 / 20	1500	2400	82
AM1LS-1209SJZ	12 (10.8-13.2)	9	106 / -	111 / 12	1500	1000	83
AM1LS-1212SJZ	12 (10.8-13.2)	12	106 / -	84 / 9	1500	560	83
AM1LS-1215SJZ	12 (10.8-13.2)	15	106 / -	67 / 7	1500	560	83
AM1LS-1224SJZ	12 (10.8-13.2)	24	103 / -	42 / 4	1500	220	85
AM1LS-1505SJZ	15 (13.5-16.5)	5	86 / -	200 / 20	1500	2400	82
AM1LS-1515SJZ	15 (13.5-16.5)	15	85 / -	67 / 7	1500	560	83
AM1LS-2405SJZ	24 (21.6-26.4)	5	55 / -	200 / 20	1500	2400	82
AM1LS-2409SJZ	24 (21.6-26.4)	9	55 / -	111 / 12	1500	1000	83
AM1LS-2412SJZ	24 (21.6-26.4)	12	55 / -	84 / 9	1500	560	83
AM1LS-2415SJZ	24 (21.6-26.4)	15	55 / -	67 / 7	1500	560	83
AM1LS-2424SJZ	24 (21.6-26.4)	24	53 / -	42 / 4	1500	220	85
AM1LS-0503SH30JZ	5 (4.5-5.5)	3.3	286 / 10	303 / 30	3000	2400	74
AM1LS-0505SH30JZ	5 (4.5-5.5)	5	286 / 10	200 / 20	3000	2400	82
AM1LS-0509SH30JZ	5 (4.5-5.5)	9	254 / 20	111 / 12	3000	1000	83
AM1LS-0512SH30JZ	5 (4.5-5.5)	12	254 / 20	84 / 9	3000	560	83
AM1LS-0515SH30JZ	5 (4.5-5.5)	15	254 / 30	67 / 7	3000	560	83
AM1LS-0524SH30JZ	5 (4.5-5.5)	24	254 / 30	42 / 4	3000	220	85
AM1LS-1205SH30JZ	12 (10.8-13.2)	5	107 / -	200 / 20	3000	2400	82
AM1LS-1209SH30JZ	12 (10.8-13.2)	9	106 / -	111 / 12	3000	1000	83
AM1LS-1212SH30JZ	12 (10.8-13.2)	12	106 / -	84 / 9	3000	560	83
AM1LS-1215SH30JZ	12 (10.8-13.2)	15	106 / -	67 / 7	3000	560	83
AM1LS-1224SH30JZ	12 (10.8-13.2)	24	103 / -	42 / 4	3000	220	85
AM1LS-1505SH30JZ	15 (13.5-16.5)	5	86 / -	200 / 20	3000	2400	82
AM1LS-1515SH30JZ	15 (13.5-16.5)	15	85 / -	67 / 7	3000	560	83
AM1LS-2405SH30JZ	24 (21.6-26.4)	5	55 / -	200 / 20	3000	2400	82
AM1LS-2409SH30JZ	24 (21.6-26.4)	9	55 / -	111 / 12	3000	1000	83
AM1LS-2412SH30JZ	24 (21.6-26.4)	12	55 / -	84 / 9	3000	560	83
AM1LS-2415SH30JZ	24 (21.6-26.4)	15	55 / -	67 / 7	3000	560	83
AM1LS-2424SH30JZ	24 (21.6-26.4)	24	53 / -	42 / 4	3000	220	85

Note: Use suffix "TR" for tape & reel packing (ex. AM1LS-0503SJZTR).

Dual Output

Model	Input Voltage (VDC)	Output Voltage (VDC)	Input Current Full No load max (mA)	Output Current max min (mA)	Isolation (VDC)	Maximum capacitive Load (μ F)	Efficiency Typ. (%)
AM1LS-0505DJZ	5 (4.5-5.5)	\pm 5	257 / 10	\pm 100/ \pm 10	1500	\pm 1200	82
AM1LS-0509DJZ	5 (4.5-5.5)	\pm 9	254 / 20	\pm 56/ \pm 6	1500	\pm 470	83
AM1LS-0512DJZ	5 (4.5-5.5)	\pm 12	254 / 20	\pm 42/ \pm 5	1500	\pm 220	83
AM1LS-0515DJZ	5 (4.5-5.5)	\pm 15	254 / 30	\pm 34/ \pm 4	1500	\pm 220	83
AM1LS-0524DJZ	5 (4.5-5.5)	\pm 24	254 / 30	\pm 21/ \pm 3	1500	\pm 100	85
AM1LS-1205DJZ	12 (10.8-13.2)	\pm 5	107 / -	\pm 100/ \pm 10	1500	\pm 1200	82
AM1LS-1209DJZ	12 (10.8-13.2)	\pm 9	106 / -	\pm 56/ \pm 6	1500	\pm 470	83
AM1LS-1212DJZ	12 (10.8-13.2)	\pm 12	106 / -	\pm 42/ \pm 5	1500	\pm 220	83
AM1LS-1215DJZ	12 (10.8-13.2)	\pm 15	106 / -	\pm 34/ \pm 4	1500	\pm 220	83
AM1LS-1224DJZ	12 (10.8-13.2)	\pm 24	103 / -	\pm 21/ \pm 3	1500	\pm 100	85
AM1LS-1515DJZ	15 (13.5-16.5)	\pm 15	85 / -	\pm 34/ \pm 4	1500	\pm 220	83
AM1LS-2405DJZ	24 (21.6-26.4)	\pm 5	55 / -	\pm 100/ \pm 10	1500	\pm 1200	82
AM1LS-2409DJZ	24 (21.6-26.4)	\pm 9	55 / -	\pm 56/ \pm 6	1500	\pm 470	83
AM1LS-2412DJZ	24 (21.6-26.4)	\pm 12	55 / -	\pm 42/ \pm 5	1500	\pm 220	83
AM1LS-2415DJZ	24 (21.6-26.4)	\pm 15	55 / -	\pm 34/ \pm 4	1500	\pm 220	83
AM1LS-2424DJZ	24 (21.6-26.4)	\pm 24	53 / -	\pm 21/ \pm 3	1500	\pm 100	85
AM1LS-0505DH30JZ	5 (4.5-5.5)	\pm 5	257 / 10	\pm 100/ \pm 10	3000	\pm 1200	82
AM1LS-0509DH30JZ	5 (4.5-5.5)	\pm 9	254 / 20	\pm 56/ \pm 6	3000	\pm 470	83
AM1LS-0512DH30JZ	5 (4.5-5.5)	\pm 12	254 / 20	\pm 42/ \pm 5	3000	\pm 220	83
AM1LS-0515DH30JZ	5 (4.5-5.5)	\pm 15	254 / 30	\pm 34/ \pm 4	3000	\pm 220	83
AM1LS-0524DH30JZ	5 (4.5-5.5)	\pm 24	254 / 30	\pm 21/ \pm 3	3000	\pm 100	85
AM1LS-1205DH30JZ	12 (10.8-13.2)	\pm 5	107 / -	\pm 100/ \pm 10	3000	\pm 1200	82
AM1LS-1209DH30JZ	12 (10.8-13.2)	\pm 9	106 / -	\pm 56/ \pm 6	3000	\pm 470	83
AM1LS-1212DH30JZ	12 (10.8-13.2)	\pm 12	106 / -	\pm 42/ \pm 5	3000	\pm 220	83
AM1LS-1215DH30JZ	12 (10.8-13.2)	\pm 15	106 / -	\pm 34/ \pm 4	3000	\pm 220	83
AM1LS-1224DH30JZ	12 (10.8-13.2)	\pm 24	103 / -	\pm 21/ \pm 3	3000	\pm 100	85
AM1LS-1515DH30JZ	15 (13.5-16.5)	\pm 15	85 / -	\pm 34/ \pm 4	3000	\pm 220	83
AM1LS-2405DH30JZ	24 (21.6-26.4)	\pm 5	55 / -	\pm 100/ \pm 10	3000	\pm 1200	82
AM1LS-2409DH30JZ	24 (21.6-26.4)	\pm 9	55 / -	\pm 56/ \pm 6	3000	\pm 470	83
AM1LS-2412DH30JZ	24 (21.6-26.4)	\pm 12	55 / -	\pm 42/ \pm 5	3000	\pm 220	83
AM1LS-2415DH30JZ	24 (21.6-26.4)	\pm 15	55 / -	\pm 34/ \pm 4	3000	\pm 220	83
AM1LS-2424DH30JZ	24 (21.6-26.4)	\pm 24	53 / -	\pm 21/ \pm 3	3000	\pm 100	85

Note: Use suffix "TR" for tape & reel packing (ex. AM1LS-0505DJZTR).

Input Specification

Parameters	Conditions	Typical	Maximum	Units
Filter	Capacitor			
Absolute maximum rating	Maximum duration 1s, 5Vin	>0.7	9	VDC
	Maximum duration 1s, 12Vin	>0.7	18	VDC
	Maximum duration 1s, 15Vin	>0.7	21	VDC
	Maximum duration 1s, 24Vin	>0.7	30	VDC
Input reflected ripple current	5Vin	15		mA
	Others	30		mA

Isolation Specification				
Parameters	Conditions	Typical	Maximum	Units
Tested I/O voltage	60 sec, leakage \leq 1mA	>1500		VDC
	60 sec, leakage \leq 1mA for H30 models	>3000		VDC
Resistance	500VDC	>1000		M Ω
Capacitance	100kHz/0.1V	20		pF

Output Specification				
Parameters	Conditions	Typical	Maximum	Units
Voltage accuracy	See output voltage tolerance	10	14	%
Line regulation	Per 1% Vin change, AM1LS-0503SJZ & AM1LS-0503SH30JZ		1.5	%
	Per 1% Vin change, others		1.2	%
Load regulation	10-100% load, 3.3Vout	15	20	%
	10-100% load, 5Vout	10	15	%
	10-100% load, 9Vout	8	10	%
	10-100% load, 12Vout	7	10	%
	10-100% load, 15Vout	6	10	%
	10-100% load, 24Vout	5	10	%
Temperature coefficient		\pm 0.02		%/ $^{\circ}$ C
Ripple & Noise*	24Vout	50	100	mV pk-pk
	Others	30	75	mV pk-pk
Minimum load**		10		%

* Ripple and Noise are measured at 20MHz bandwidth. Please refer to the application note for specific details.

** If the required power is less than 1% of the rated converter output, connect a bleeder resistor in parallel with the load to satisfy the minimum load requirement.

General Specifications				
Parameters	Conditions	Typical	Maximum	Units
Switching frequency	Full load, nominal input, 5Vin	270		KHz
	Full load, nominal input, others	260		KHz
Short circuit protection	Continuous, Auto recovery			
Operating temperature	With derating at 100 $^{\circ}$ C	-40 to +105		$^{\circ}$ C
Storage temperature		-55 to +125		$^{\circ}$ C
Maximum Case temperature		130		$^{\circ}$ C
Reflow soldering temperature	Maximum duration 60s when over 217 $^{\circ}$ C		245	$^{\circ}$ C
Soldering method	IPC/JEDEC J-STD-020D.1.			
Cooling	Free air convection			
Humidity	Non-condensing	>5	95	% RH
Moisture sensitivity level	Level 1			
Case material	Black plastic (flammability to UL 94V-0)			
Weight		1.4		g
Dimensions (L x W x H)	Single output models	0.52 x 0.45 x 0.28 inches (13.20 x 11.40 x 7.25 mm)		
	Dual output models	0.60 x 0.45 x 0.28 inches (15.24 x 11.40 x 7.25 mm)		
MTBF	3 500 000 hrs (MIL-HDBK -217F, t=+25 $^{\circ}$ C) / Full Load			
NOTE: All specifications in this datasheet are measured at an ambient temperature of 25 $^{\circ}$ C, humidity<75%, nominal input voltage and at rated output load unless otherwise specified.				

Safety Specifications		
Parameters		
Agency approvals	cUL _{US} , UL62368-1(5Vin models only)	
Standards	Information technology Equipment	Design to meet IEC/EN/UL 62368-1
	EMC - Conducted and radiated emission	CISPR32 / EN55032, class B with the recommended EMI circuit
	Electrostatic Discharge Immunity	IEC 61000-4-2 Air ±8KV, Contact ±4KV, Criteria B (5Vin models) IEC 61000-4-2 Contact ±6KV, Criteria B (Other models)

Derating

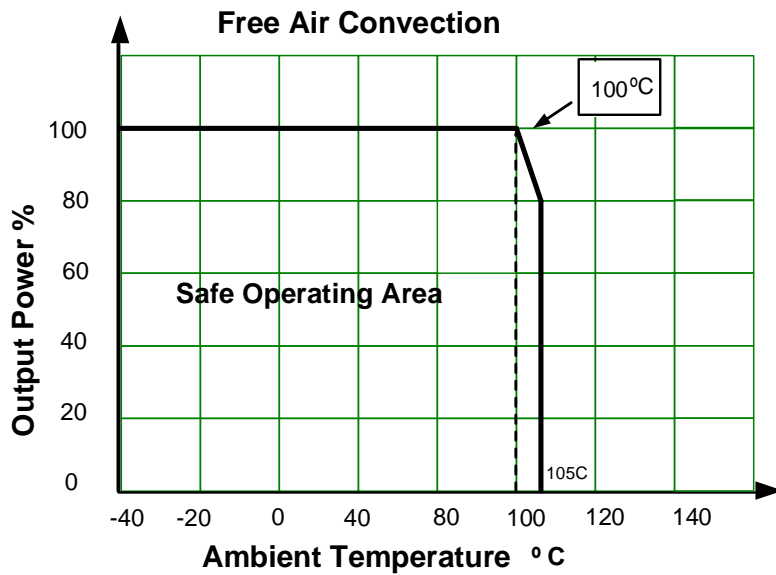

Output voltage tolerance

For AM1LS-0503SJZ & AM1LS-0503SH30JZ

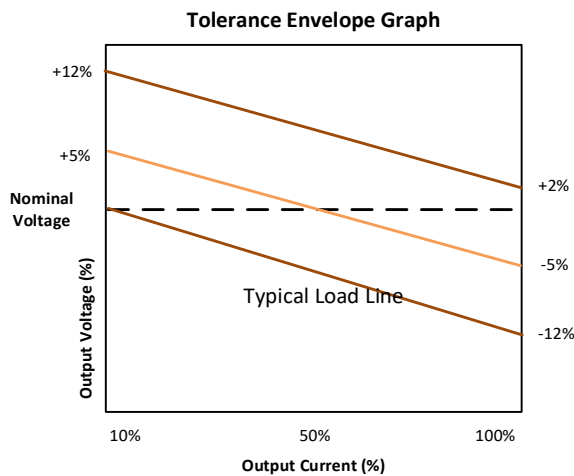

For other 5Vin models

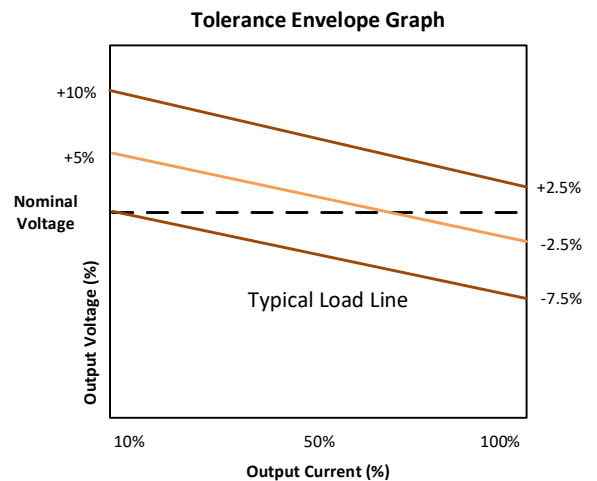

For other models

Tolerance Envelope Graph

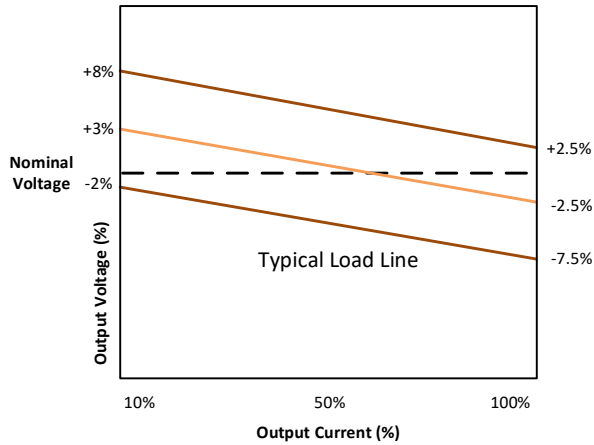

Typical application circuit

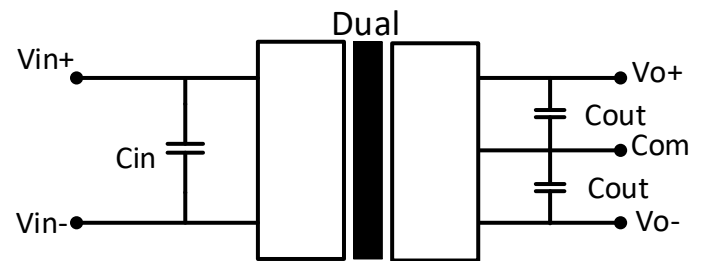
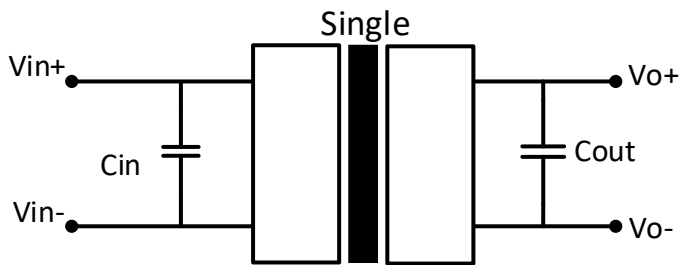

5Vin models

Vin	Cin	Single output models		Dual output models	
		Vout	Cout	Vout	Cout
5	4.7μF	3.3V	10μF	±5V	4.7μF
-	-	5V	10μF	±9V	2.2μF
-	-	9V	4.7μF	±12V	1μF
-	-	12V	2.2μF	±15V/±24V	1μF
-	-	15V	1μF		
-	-	24V	0.47μF		

Other Vin models

Vin	Cin	Single output models		Dual output models	
		Vout	Cout	Vout	Cout
12	2.2μF/25V	5V	10μF/16V	±5V	4.7μF/16V
15	2.2μF/25V	9V	2.2μF/16V	±9V	1μF/16V
24	1μF/50V	12V	2.2μF/25V	±12V	1μF/25V
-	-	15V	1μF/25V	±15V	0.47μF/25V
-	-	24V	1μF/50V	±24V	0.47μF/50V

EMI Recommended circuit



Single output models

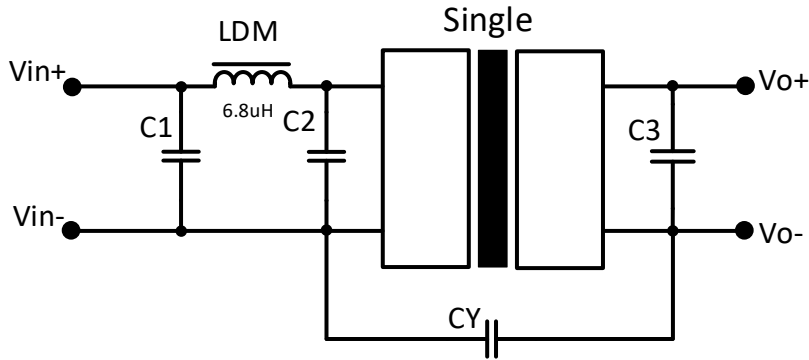

Vin	C1/C2	Vout	CY		C3
			1500VDC isolation	3000VDC isolation	
5V	4.7μF/25V	3.3V/5V/9V	-	-	Refer to Cout in typical circuit
		12V/15V/24V	1nF/2kVDC	1nF/4kVdc	Refer to Cout in typical circuit
12V/15V/24V	4.7μF/50V	All output	270pF/2Vdc	270pF/3kVdc	Refer to Cout in typical circuit

Dual output models

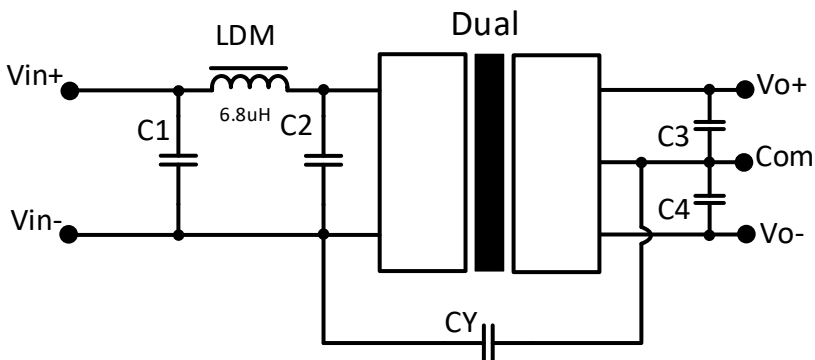

Vin	C1/C2	Vout	CY		C3/C4
			1500VDC isolation	3000VDC isolation	
5V	4.7μF/25V	5V/9V	-	-	Refer to Cout in typical circuit
		12V/15V/24V	1nF/2kVDC	1nF/4kVdc	Refer to Cout in typical circuit
12V/15V/24V	4.7μF/50V	All output	270pF/2Vdc	270pF/3kVdc	Refer to Cout in typical circuit

Dimensions

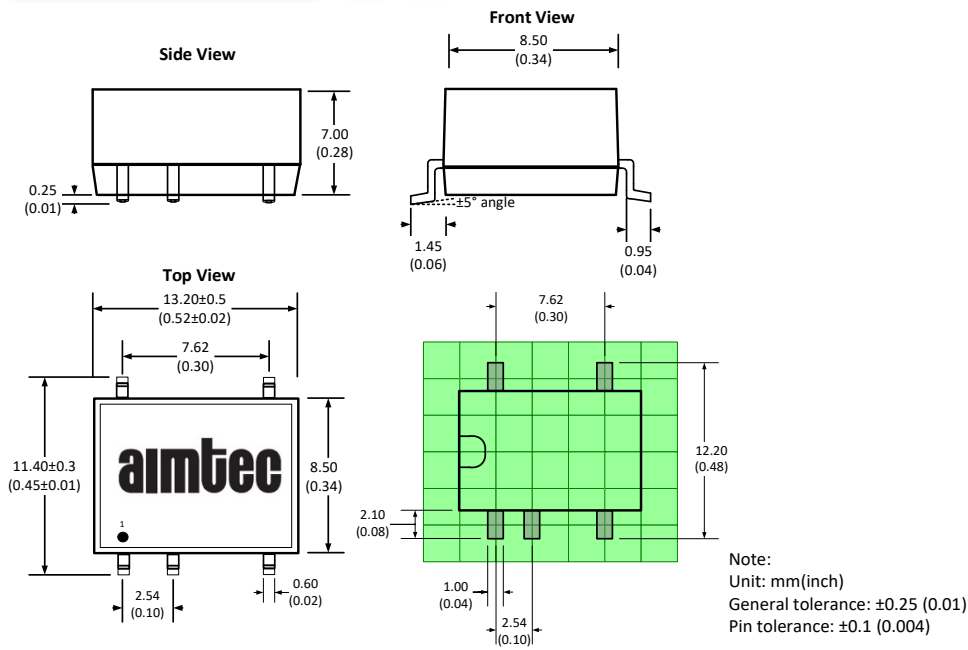

Pin Out Specifications		
Pin	Single	Dual
1	-V Input	-V Input
2	+V Input	+V Input
3	-	-
4	-V Output	Common
5	+V Output	-V Output
6	-	-
7	-	+V Output
8	NC	-
9	-	-
10	-	NC

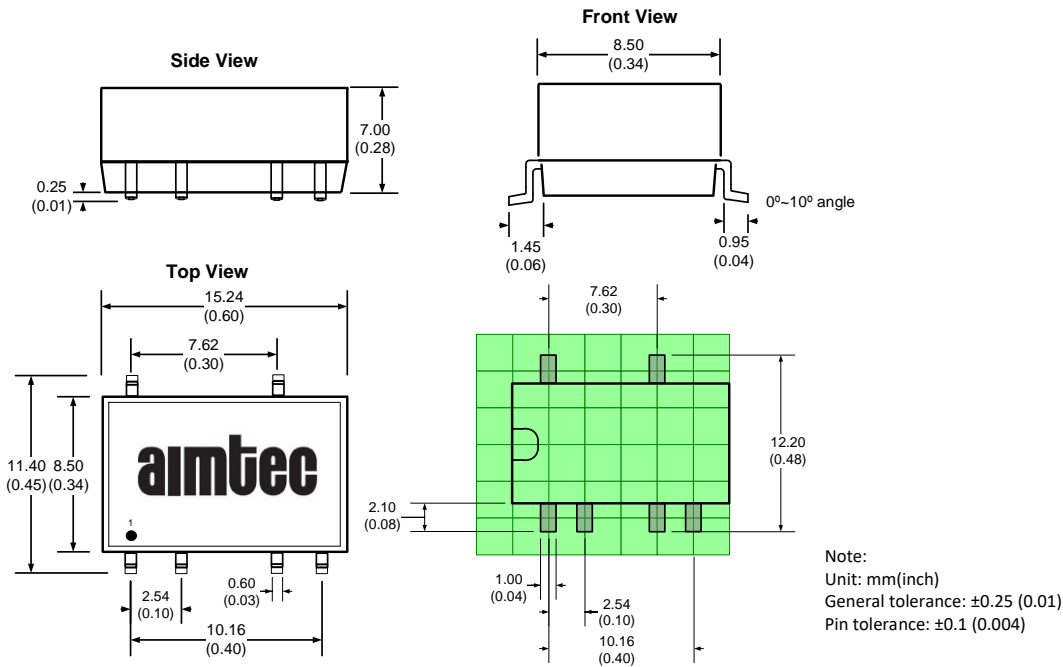

Packing Information

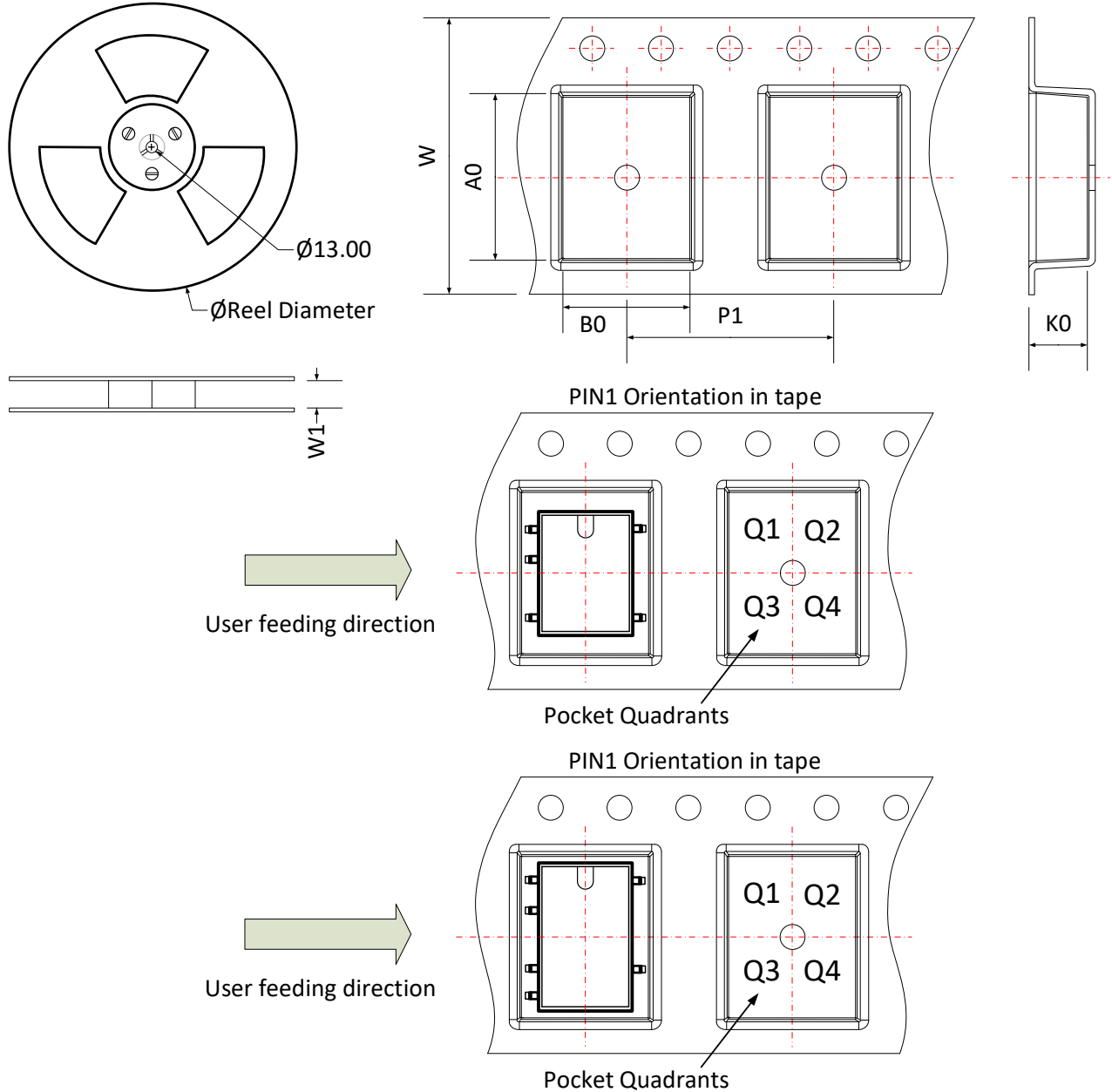

Device	Package Type	Pin	MPQ	Reel Diameter (mm)	Reel Width W1 (mm)	A0	B0	K0	P1	W	P1 Quadrant
AM1LS-JZ Single output	SMD	5	500	330.0	24.5	13.4	11.7	7.5	16.0	24.0	Q1
AM1LS-JZ Dual output	SMD	6	500	330.0	24.5	15.64	12.4	7.45	16.0	24.0	Q1

NOTE: 1. Datasheets are updated as needed and as such, specifications are subject to change without notice. Once printed or downloaded, datasheets are no longer controlled by Aimtec; refer to www.aimtec.com for the most current product specifications. **2.** Product labels shown, including safety agency certifications on labels, may vary based on the date manufactured. **3.** Mechanical drawings and specifications are for reference only. **4.** All specifications are measured at an ambient temperature of 25°C, humidity<75%, nominal input voltage and at rated output load unless otherwise specified. **5.** Aimtec may not have conducted destructive testing or chemical analysis on all internal components and chemicals at the time of publishing this document. CAS numbers and other limited information are considered proprietary and may not be available for release. **6.** This product is not designed for use in critical life support systems, equipment used in hazardous environments, nuclear control systems or other such applications which necessitate specific safety and regulatory standards other the ones listed in this datasheet. **7.** Warranty is in accordance with Aimtec's standard Terms of Sale available at www.aimtec.com.